

„TRI-EX“-Absperrklappe metalledicht, PN 10 bis PN 40, t = -200°C bis +450°C

zum Einschweißen oder mit Flanschen, für Betriebsdrücke bis zu 40 bar.
 Klappenscheibe doppeltezzentrisch gelagert, Sitzgeometrie „trizentrisch“ und damit verschleiß- und klemmfrei dichtschließend.
 Strömungsgünstige Klappenscheibe, geeignet zum Absperrn und Regeln.

Gehäuse und Scheibe aus unlegiertem oder legiertem Stahl, einteilige Welle mit wartungsarmer Stopfbuchse aus Grafit.
 Gehäusesitz und austauschbare Lamellen-Dichtung korrosionsbeständig aus hochlegiertem Stahl.

„TRI-EX“-Butterfly valve metal/metal-sealing, class 150 to 600, t = -200°C to +450°C

Connections welded or flanged, for cryogenic and high-temperature and design pressure up to 40 bar.
 Disc design double-eccentric, the “trizentric” seat-geometry tightens in both directions without wearing and galling.
 For shut-off and control service.

Body and disc made of carbon - low or high alloyed steel, stuffing box with graphite packing.
 Shaft, body and the interchangeable lamellar seal in the disc made of stainless steel.

Lieferprogramm / Scope of supply

Bestell-Nr. Order-no.	Anschluss End connection	DN Nominal Ø	PN / Class bis / Up to	pb, [bar] Maximum	Baulänge Face-to-face dimension
mit Handrad / Manual AK110F-H	mit Flansch Flanged	100 - 600	PN 40 / Class 300	40	EN558-2 ANSI-B16.47
mit E-Antrieb / Electric AK110F-E		900 - 1200	PN 25 / Class 300	25	
			PN 16 / Class 150	16	
			PN 10 / Class 150	10	
mit Handrad / Manual AK110E-H	zum Einschweißen Butt welded	100 - 600	PN 40 / Class 300	40	EN558-2 ANSI-B16.47
mit E-Antrieb / Electric AK110E-E		900 - 1200	PN 25 / Class 300	25	
			PN 16 / Class 150	16	
			PN 10 / Class 150	10	

Das optimale Dichtprinzip: „TRI-EX“

High performance design:

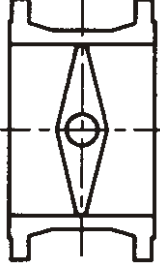
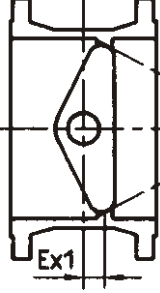
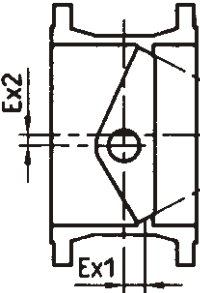
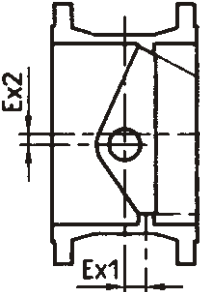
System	Typ / Sitz-Dichtung Type / seat material	Dauertemperatur Service-temperature	Reibung im Sitz Friction in the seat	Verschleiß im Sitz Wearing in the seat
	zentrische Klappe Centric design nur Gummi- dichtung möglich Only soft sealing possible	bis / Up to 100°C	bei 100% des Stellwinkels At 100% of disc operation	sehr hoch Very high
	exzentrische Klappe Eccentric design nur Gummi- dichtung möglich Only soft sealing possible	bis / Up to 130°C	bei 30% des Stellwinkels At 30% of disc operation	gering Low
	doppelt exzentrische Klappe Double-eccentric design Metall-Dichtung möglich Metal sealing is possible	bis / Up to 350°C	bei 10% des Stellwinkels At 10% of disc operation	hoch (für Metall-Sitz) High (for metal seat)
	3-fach exzentrisch 3-eccentric design "TRI-EX" Metall-Dichtung optimiert Typical for metal sealing	bis / Up to 450°C	bei <1% des Stellwinkels At <1% of disc operation	kein Verschleiß No wear (nur Anpressen) (Compression only)

Vorteile des „TRI-EX“-Prinzips:

- Keine Sitzreibung: Erst unmittelbar in der ZU-Stellung berühren sich die Dichtflächen, das Schließmoment des Antriebs erzeugt dann die notwendige Flächenpressung zum dichten Schließen.
- Der Antriebsbedarf ist gegenüber rein doppelt-exzentrischen Klappen deutlich reduziert.
- Kein Klemmen bei Temperaturwechseln in ZU-Stellung. Der Sitz bleibt elastisch nachgiebig und dicht.

Advantages of the "TRI-EX"-system:

- No wearing: Metal-to-metal seat system prevents rubbing. Shuts tight with seat compression by actuator torque.
- Prevents friction in the seat and allows small actuator units.
- Elastic seat elements are self-compensating for temperature variances.

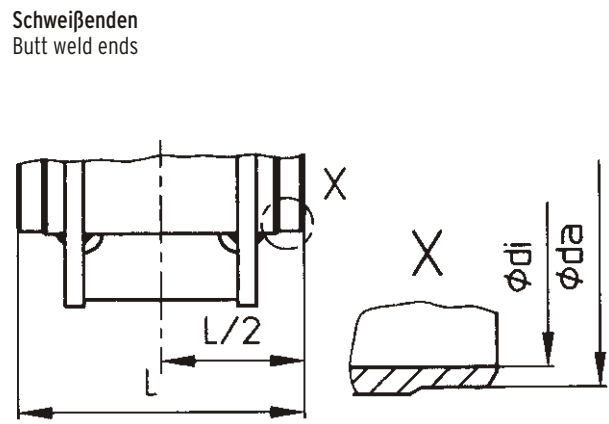
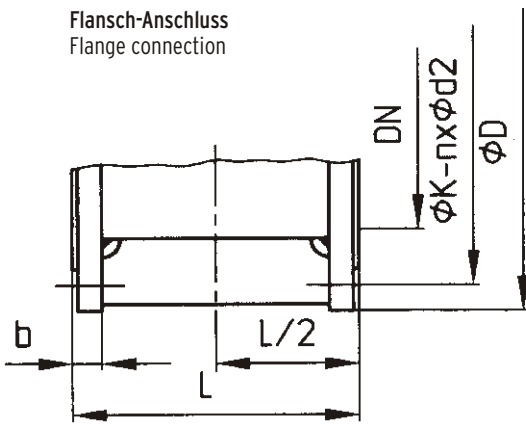

Normmaße entsprechen dem derzeitigen Stand der Technik, Gewichte sind Richtwerte. Die Änderung bleibt vorbehalten.
All dimensions according to the actual standards. Weight is approximate. We reserve the right of revision.

Baulängen / Face-to-face dimensions

Anschluss	Connection	Norm	DN	100	125	150	200	250	300	350	400	450	500	600	700	800	900	1000	1200
Flansche	Flanged	EN558-2-14	L	190	200	210	230	250	270	290	310	330	350	390	430	470	510	550	630
Schweißenden	Butt welding ends	EN558-2-14	L	190	200	210	230	250	270	290	310	330	350	390	430	470	510	550	630

Flansch-Anschluss / Flanged connection

PN	DN	100	125	150	200	250	300	350	400	450	500	600	700	800	900	1000	1200
16	D	220	250	285	340	405	460	520	580	640	715	840	910	1025	1125	1255	1485
	b	20	22	22	24	26	28	30	32	34	34	36	36	38	40	42	48
	kØ	180	210	240	295	355	410	470	525	585	650	770	840	950	1050	1170	1390
	n	8	8	8	12	12	12	16	16	20	20	20	24	24	28	28	32
	d2	18	18	22	22	26	26	26	30	30	33	36	36	39	39	42	48
25	D	235	270	300	360	425	485	555	620	670	730	845	960	1085	1185	1320	-
	b	24	26	28	30	32	34	38	40	42	44	46	46	50	32	32	-
	kØ	190	220	250	310	370	430	490	550	600	660	770	875	990	1090	1210	-
	n	8	8	8	8	12	16	16	16	20	20	20	24	24	28	28	-
	d2	22	26	26	26	30	30	33	36	36	36	39	42	48	48	56	-
40	D	235	270	300	375	425	515	580	650	685	755	-	-	-	-	-	-
	b	24	26	28	34	32	42	46	50	52	52	-	-	-	-	-	-
	kØ	190	220	250	320	370	450	510	585	610	670	-	-	-	-	-	-
	n	8	8	8	12	12	16	16	16	20	20	-	-	-	-	-	-
	d2	22	26	26	30	33	33	36	39	39	42	-	-	-	-	-	-

Flansche PN 10 und PN 63 auf Kundenwunsch / Flanges PN 10 and PN 63 ANSI B 16.5 or other standards on request

Schweißenden / Butt welding ends DIN 2559-1, Form 22

PN	DN	100	125	150	200	250	300	350	400	450	500	600	700	800	900	1000	1200
16-40	Ø da	115	140	169	219	273	324	356	407	457	508	610	711	813	914,4	1016	1220
	Ø di*)	107	131	158	205	256	302	351	385	433	480	585	686	785	894,4	996	1195

*) größere Ø di nach Kundenwunsch / Ø di larger on request

Gewicht [kg] / Weight [kg]

PN		DN	100	125	150	200	250	300	350	400	450	500	600	700	800	900	1000	1200
16	Hand	Manual	35	38	61	66	108	160	175	330	350	510	740	1050	1620	1960	2570	3780
	E-Antrieb	Electric	59	62	85	99	132	185	200	355	475	540	770	1080	1670	2030	2630	3840
25	Hand	Manual	44	48	67	104	132	195	270	390	490	650	850	1620	2040	2420	3060	4780
	E-Antrieb	Electric	68	72	91	128	156	220	295	415	515	680	890	1650	2100	2480	3130	4850

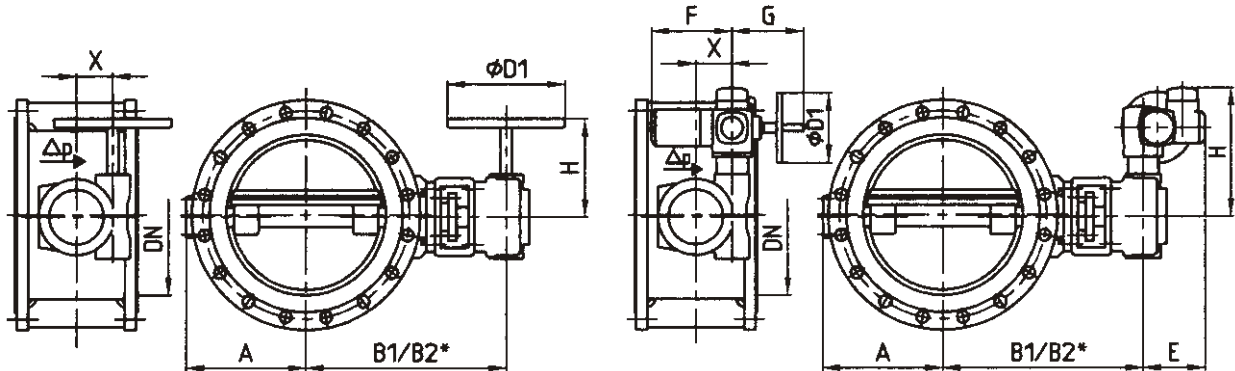

*B1: t < 250°C / B2: t ≥ 250°C

A, B1 / B2, X wie Klappe mit Handrad / Identical to manual gear

Baumaße (±10%) und Werkstoffe entsprechen dem derzeitigen Stand der Technik, die Weiterentwicklung bleibt vorbehalten.
Overall dimensions (±10%) according to the current standards. We reserve the right to change technical details or materials.

mit Schneckengetriebe und Handrad / Manual with worm gear

PN	DN	100	125	150	200	250	300	350	400	450	500	600	700	800	900	1000	1200
10/16	A	140	160	180	200	260	290	310	340	390	420	510	550	640	685	711	827
	B1	290	352	414	446	529	572	630	665	689	732	811	862	975	1151	1190	1316
	B2	390	452	514	546	629	672	730	765	789	832	911	962	1075	1251	1290	1416
	H	155	155	195	200	200	200	280	280	290	340	455	540	540	620	620	620
	X	50	50	63	80	80	80	100	100	125	125	160	200	200	200	250	250
16	ØD1	200	200	300	350	350	500	500	500	600	350	500	500	500	500	500	500
	B1	290	352	414	446	529	572	630	665	689	732	811	862	975	1166	1200	1321
	B2	390	452	514	546	629	672	730	765	789	832	911	962	1075	1266	1300	1421
	H	155	155	195	200	200	200	280	290	340	340	455	540	540	620	620	760
	X	50	50	63	80	80	80	100	125	125	125	160	200	200	250	250	315
25	ØD1	200	200	300	350	350	500	500	600	350	350	500	500	500	500	500	600
	A	140	160	180	200	260	290	310	340	390	420	510	560	650	685	711	827
	B1	290	352	414	446	529	600	630	665	689	732	811	887	1015	1176	1205	1351
	B2	390	452	514	546	629	700	730	765	789	832	911	987	1115	1276	1305	1451
	H	155	155	195	200	200	280	280	340	340	455	540	540	620	620	760	860
40	X	50	50	63	80	80	100	100	125	125	160	200	200	250	250	315	400
	ØD1	200	200	300	350	350	500	500	600	350	350	500	500	500	500	600	600
	A	140	160	180	200	260	290	310	340	390	420	510	-	-	-	-	-
	B1	290	354	419	446	557	600	630	665	704	747	836	-	-	-	-	-
	B2	390	454	519	546	657	700	730	765	804	847	936	-	-	-	-	-
	H	155	195	200	200	280	280	290	455	455	455	540	-	-	-	-	-
	X	50	63	80	80	100	100	125	160	160	160	200	-	-	-	-	-
	ØD1	200	300	350	350	500	500	600	500	500	500	500	-	-	-	-	-

mit Schneckengetriebe und E-Antrieb (AUMA) / With electric actuator (AUMA)

PN	DN	100	125	150	200	250	300	350	400	450	500	600	700	800	900	1000	1200	
10	E	237	237	237	237	247	237	237	237	247	237	247	247	247	247	285	247	
	F	265	265	265	265	282	265	265	265	282	265	282	282	282	282	384	282	
	G	249	249	249	249	254	249	249	249	249	254	249	254	254	254	329	254	
	H	373	373	398	403	405	532	532	537	537	539	613	615	745	745	745	860	960
	ØD1	160	160	160	160	200	160	160	160	160	200	160	200	200	200	200	315	200
16	E	237	237	237	237	237	237	237	247	237	237	237	247	285	285	247	285	
	F	265	265	265	265	265	265	265	282	265	265	265	282	384	384	282	384	
	G	249	249	249	249	249	249	249	254	249	249	249	254	329	329	254	329	
	H	373	373	398	403	532	532	537	539	613	613	743	745	860	860	960	1101	
	ØD1	160	160	160	160	160	160	160	160	160	160	160	200	315	315	200	315	
25	E	237	237	237	247	237	237	247	237	237	247	247	285	285	247	285	285	
	F	265	265	265	282	265	265	282	265	265	282	282	384	384	282	384	384	
	G	249	249	249	254	249	249	254	249	249	254	254	329	329	254	329	336	
	H	373	398	398	405	532	537	539	613	613	615	745	860	860	800	1101	1345	
	ØD1	160	160	160	200	160	160	200	160	160	200	200	315	315	200	315	400	
40	E	237	237	237	237	247	247	247	247	237	247	247	-	-	-	-	-	
	F	265	265	265	265	282	282	282	282	265	282	282	-	-	-	-	-	
	G	249	249	249	249	254	254	254	249	254	254	254	-	-	-	-	-	
	H	373	398	403	532	532	539	539	615	743	745	800	-	-	-	-	-	
	ØD1	160	160	160	160	160	200	200	200	160	200	200	-	-	-	-	-	

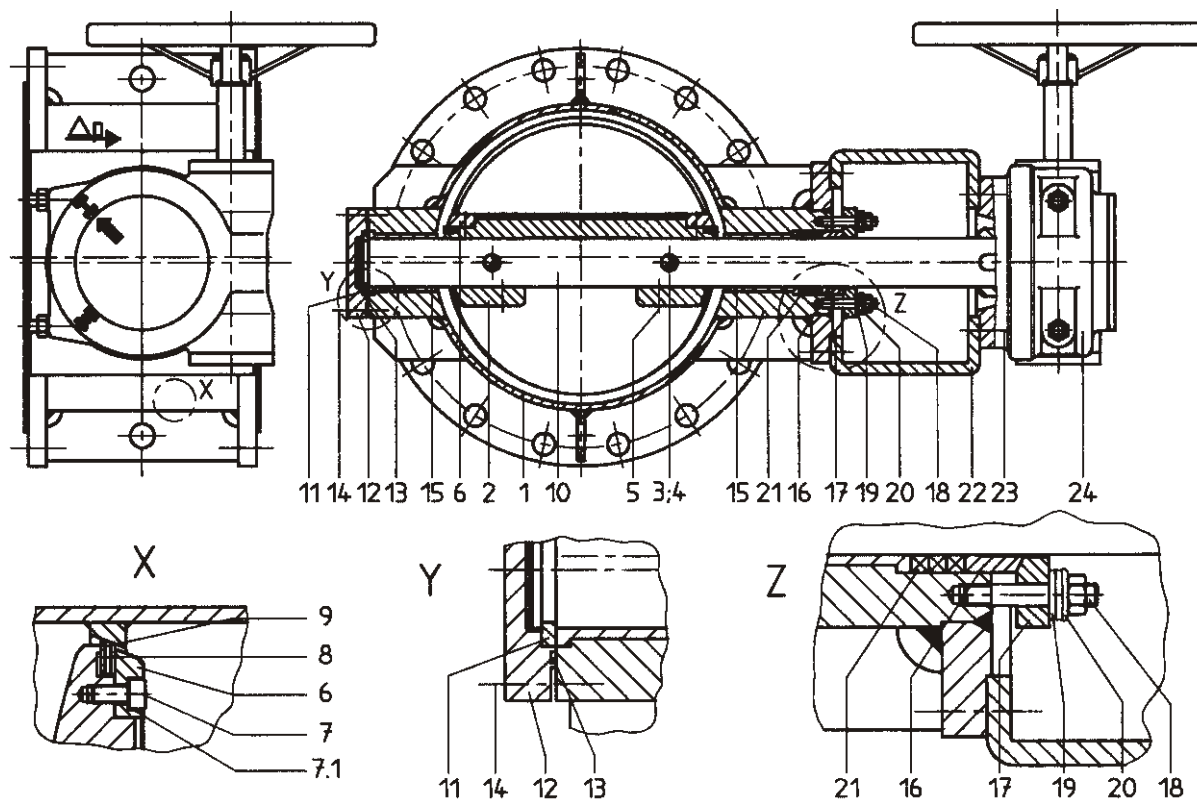

Werkstoffe / Materials

Pos. Item	Benennung	Designation	Werkstoff / Material					
			bis / Up to 300°C		bis / Up to 400°C		bis / Up to 450°C	
1	Gehäuse	Body	S235JRG2 (RS137-2)	1.0038	P265GH (HII)	1.0425	16Mo3	1.5415
1.1	Gehäusesitz	Body seat	X4CrNi18-10	1.4301	X4CrNi18-10	1.4301	X4CrNi18-10	1.4301
2	Scheibe	Disc	S235JRG2 (RS137-2)	1.0038	P265GH (HII)	1.0425	16Mo3	1.5415
3	Kegelstift	Conic pin	X19CrNi17-2	1.4057	X39CrMo17-1	1.4122	X39CrMo17-1	1.4122
6	Haltering	Retaining ring	S235JRG2 (RS137-2)	1.0038	P265GH (HII)	1.0425	P265GH (HII)	1.0425
7	Schraube	Screw	A4	-	A4	-	A4	-
8*)	Dichtung	Gasket	Grafit + X4CrNiMo17-12-2 1.4401					
9*)	Dichtelement	Seat ring	X6CrNiMoTi17-12-2 1.4571 + Weichstoff					
10	Welle	Shaft	X20Cr13	1.4021	X20Cr13	1.4021	X39CrMo17-1	1.4122
11	Axiallager	Ring	X4CrNi18-10 1.4301 + tenifer					
12	Deckel	Cover	S235JRG2 (RS137-2)	1.0038	16Mo3	1.5415	16Mo3	1.5415
13*)	Dichtung	Gasket	Grafit + X4CrNiMo17-12-2 1.4401					
14	Schraube	Screw	5.6	-	C45E	1.1191	C45E	1.1191
15	Lager	Bush	X4CrNi18-10 1.4301 + tenifer					
16	Stopfbuchse	Stuffing box	X4CrNi18-10	1.4301	X4CrNi18-10	1.4301	X4CrNi18-10	1.4301
17	Schraube	Screw	A4	-	A4	-	A4	-
18	Mutter	Nut	A2	-	A2	-	A2	-
21*)	Packung	Packing	Grafit					
22	Laterne	Yoke	P235T1 (St37)	1.0254	P235T1 (St37)	1.0254	P235T1 (St37)	1.0254
24	Getriebe	Worm gear						

*) empfohlenes Ersatzteil / Recommended spare part

Prüfdrücke und maximal zulässiger Betriebsdruck pb / Test pressure and max. working pressure pb

PN	Werkstoff Material		Prüfdruck Test pressure		pb [bar]											
			Gehäuse Body	Sitz Seat	t=100°C	200°C	250°C	300°C	350°C	400°C	450°C					
16	S235JRG2	1.0038	24	16	16	14	13	11								
	P265GH	1.0425			16	14	13	11	9	7						
	16Mo3	1.5415			16	16	15	13	12	11	10					
25	S235JRG2	1.0038	38	25	25	20	18	16								
	P265GH	1.0425			25	21	19	16	14	12						
	16Mo3	1.5415			25	25	24	22	20	19	17					
40	S235JRG2	1.0038	60	40	40	32	28	24								
	P265GH	1.0425			40	33	30	25	22	20						
	16Mo3	1.5415			40	40	38	35	31	30	26					

Durchfluss-Kennwerte Kvs [m³] / Flow capacity Kvs [m³] (cv - value = 1.15 x Kvs)

PN	DN 100	125	150	200	250	300	350	400	450	500	600	700	800	900	1000	1200
10 / 16	215	415	570	915	1655	3025	5665	7995	8985	13250	17300	20560	41060	45123	55480	81427
25	215	415	570	915	1655	2505	4860	6290	7960	10490	14360	19200	29875	39465	48420	72170
40	215	415	570	915	1460	2430	3770	5335	6850	8770	13090	17800	26950	36586	45961	66832

Regel-Kennlinie Kv [m³] = f (Öffnungswinkel) PN 25 / Control characteristic Kv [m³] = f (disc position) PN 25 (cv - value = 1.15 x Kvs)

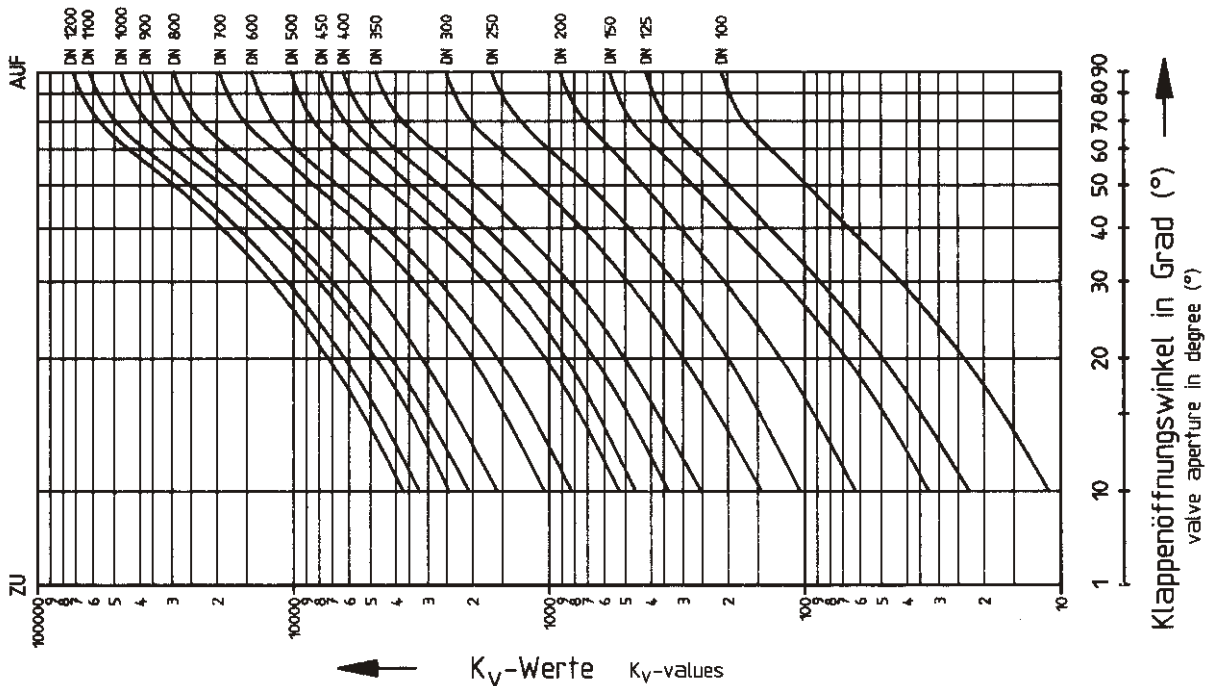

Sonderausführungen:

- andere Werkstoffe wie Edelstahl, Hastelloy und Titan auf Anfrage

Special designs:

- Other materials as stainless steel, hastelloy or titanium on request

Die beschriebenen Armaturen entsprechen in Ihrer Konstruktion, ihren Abmessungen, Gewichten und Werkstoffen dem derzeitigen Stand der Technik. Änderungen im Zuge der Weiterentwicklung, sowie die Verwendung gleich- oder höherwertiger Werkstoffe bleiben vorbehalten. Für eventuelle Schreib- oder Übersetzungsfehler übernehmen wir keine Haftung. The construction, the measurements and the weights of the described valves represent the current technical standards. We reserve the right to change the technical details and to use materials of equivalent and higher quality. We cannot be held responsible for any printing or translation errors that might be found in this catalogue.