

Fixed Pivot and Snap Action Drain Traps

For Loads to 1 770 kg/h...Pressures to 69 bar



Model No.	Cast Iron		Forged Steel	
	21 †	71-A*	21-312 †	71-315*
Pipe Connections	15 – 20	20 – 25	15 – 20 – 25	20 – 25 – 32 – 40
"A"	157	216	171	248
"B"	133	273	259	381
"BB" (PN100**)	–	–	300 – 305 – 313	433 – 433 – 437
"D"	–	108	141	198
"K"	33	–	32	–
"L"	–	89	86	117
"LL" (PN100**)	–	–	127 – 132 – 140	169 – 169 – 173
Weight in kg (screwed & SW)	4	13	14	42
Weight in kg (flanged PN100**)	–	–	15,8 – 17,8 – 18,8	43,5 – 46,5 – 48,8
Maximum Allowable Pressure (Vessel Design)	17 bar @ 232°C		41 bar @ 38°C 34 bar @ 400°C	69 bar @ 38°C 41 bar @ 400°C

† Cast 316 stainless steel body and cap with all stainless steel internals available. Aluminum body and cap available for Model 21 only. Consult factory.

* Snap action drain traps **should not** be used where load exceeds 54 kg/h. Use on greater loads shortens spring life.

** Other flange sizes, ratings and face-to-face dimensions are available on request.

All models comply with the article 3.3 of the PED (97/23/EC).

Table LD-457-2. 21-LD and 71-LD List of Materials					
Model No.	Valve & Seat	Leverage System	Float	Body & Cap	Gasket
21	Stainless Steel			Cast Iron ASTM A48 Class 30	Compressed Asbestos-free
71-A				Forged Steel* ASTM A105	
21-312 71-315					

* Model 71-315 cap is cast steel.

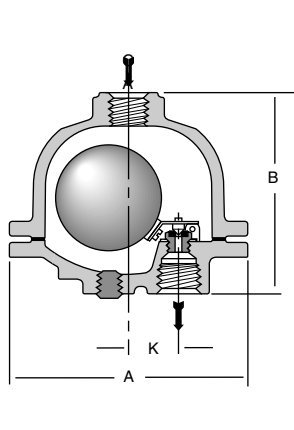

Figure LD-457-1.
Model 21 cast iron fixed lever drain trap.

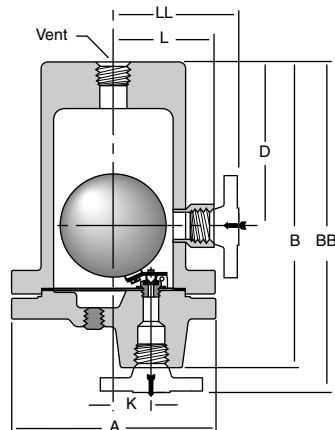

Figure LD-457-2.
Model 21-312 forged steel fixed lever drain trap.

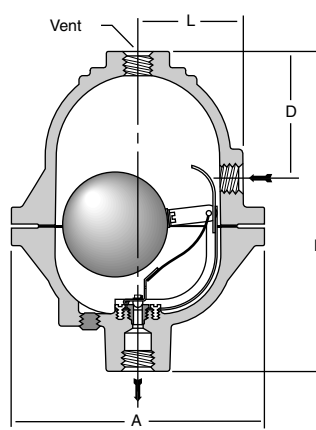

Figure LD-457-3.
Model 71-A cast iron snap action drain trap.

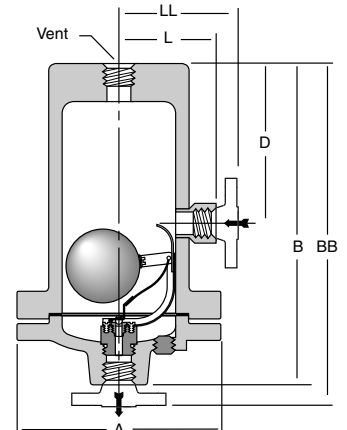

Figure LD-457-4.
Model 71-315 forged steel snap action drain trap.

Liquid Drainers

All dimensions and weights are approximate. Use certified print for exact dimensions. Design and materials are subject to change without notice.



High Leverage Spring-Loaded Ball Float Type Drain Traps

For Low Flows at Pressures to 255 bar and Specific Gravity Down to 0,40

The Armstrong High Leverage Series of liquid drain traps was developed especially for draining low specific gravity fluids from gases at high pressures. They use standard Armstrong forged steel bodies with very high leverage systems and spring assist.

Because of design considerations in this drain trap, it is essential that a safety factor of at least 2 be applied to the peak liquid load for sizing purposes.

Note: Models 2313-HLS, 2316-HLS, 2413-HLS and 2415-HLS are also available with cast T-316 stainless steel body and all-stainless steel internals. Consult factory.

Do not use HLS drain traps on steam service.

Sour Gas Service
 Forged steel and stainless steel traps can be modified to resist hydrogen sulfide stress corrosion. These modifications involve annealing the float, which will reduce the maximum working pressure of the float to about half its normal value. Consult Armstrong Application Engineering for allowable working pressures.

Model No.	Float Diameter	Unbalanced Float Weight
2313-HLS 2413-HLS 25133G-HLS	89 mm	113 g
2315-HLS 2415-HLS 25155G-HLS 26155G-HLS	102 mm	128 g
2316-HLS 2416-HLS	127 mm	170 g

Model No.	Sp. Grav.	1,00	0,95	0,90	0,85	0,80	0,75	0,70	0,65	0,60	0,55	0,50	0,45	0,40
		Maximum Operating Pressure in bar @ 38°C												
	Orifice (in)	bar	bar	bar	bar	bar	bar	bar	bar	bar	bar	bar	bar	bar
2313-HLS	1/16"	69	69	69	69	69	69	69	69	69	69	69	69	43
	5/64"	69	69	69	69	69	69	69	69	69	69	65	47	29
	3/32"	69	69	69	69	69	69	69	69	69	58	46	33	20
	7/64"	69	69	69	69	69	69	69	63	53	44	34	25	15
	1/8"	69	69	69	69	69	63	56	48	41	34	26	19	11,7
2315-HLS	3/32"	69	69	69	69	69	69	69	69	69	69	69	69	66
	1/8"	69	69	69	69	69	69	69	69	69	69	62	50	38
	5/32"	69	69	69	69	69	69	69	64	56	48	40	33	25
	3/16"	69	69	69	67	61	56	50	45	39	34	28	23	17
2316-HLS	3/32"	69	69	69	69	69	69	69	69	69	69	69	69	69
	1/8"	69	69	69	69	69	69	69	69	69	69	69	69	69
	5/32"	69	69	69	69	69	69	69	69	69	69	69	69	69
	3/16"	69	69	69	69	69	69	69	69	69	69	69	69	57
	7/32"	69	69	69	69	69	69	69	69	69	69	61	52	43
2413-HLS	1/16"	103	103	103	103	103	103	103	103	103	103	98	71	43
	5/64"	103	103	103	103	103	103	103	103	101	83	65	47	29
	3/32"	103	103	103	103	103	103	97	84	71	58	46	33	20
	7/64"	103	103	103	101	91	82	72	63	53	44	34	25	15
2415-HLS	3/32"	124	124	124	124	124	124	124	124	124	124	108	87	66
	1/8"	124	124	124	124	124	122	110	98	86	74	62	50	38
	5/32"	119	111	103	95	87	80	72	64	56	48	40	33	25
	3/16"	83	78	72	67	61	56	50	45	39	34	28	23	17
2416-HLS	3/32"	110	110	110	110	110	110	110	110	110	110	110	110	110
	1/8"	110	110	110	110	110	110	110	110	110	110	110	110	110
	5/32"	110	110	110	110	110	110	110	110	110	110	110	102	84
	3/16"	110	110	110	110	110	110	110	110	109	97	84	72	59
	7/32"	110	110	110	110	110	108	99	90	81	71	62	53	44
25133G-HLS	1/16"	146	146	146	146	146	146	146	146	146	125	98	71	43
	5/64"	146	146	146	146	146	146	137	119	101	83	65	47	29
	3/32"	146	146	146	135	122	110	97	84	71	58	46	33	20
	7/64"	129	120	110	101	91	82	72	63	53	44	34	25	15
25155G-HLS	5/64"	174	174	174	174	174	174	174	174	174	174	152	123	93
	3/32"	174	174	174	174	174	174	174	170	150	129	108	87	66
	1/8"	174	171	159	147	135	122	110	98	86	74	62	50	38
	5/32"	119	111	103	95	87	80	72	64	56	48	40	33	25
	3/16"	83	78	72	67	61	56	50	45	39	34	28	23	17
26155G-HLS	5/64"	255	255	255	255	255	255	255	241	211	182	152	123	93
	3/32"	255	255	255	254	233	212	191	170	150	129	108	87	66
	1/8"	183	171	159	147	135	122	110	98	86	74	62	50	38
	5/32"	119	111	103	95	87	80	72	64	56	48	40	33	25
	3/16"	83	78	72	67	61	56	50	45	39	34	28	23	17
Specific Gravity		1,00	0,95	0,90	0,85	0,80	0,75	0,70	0,65	0,60	0,55	0,50	0,45	0,40

Note: If actual specific gravity falls between those shown in above table, use next lower. For example, if actual gravity is 0,73, use 0,70 data.

Liquid Drainers