



Typical Installations

Model 1-AVC Air Vent

This bulletin should be used by experienced personnel as a guide to typical installations of the Model 1AVC Air Vent. Selection or installation of equipment should always be accompanied by competent technical assistance. We encourage you to contact Armstrong International or its local representative if further information is required. To obtain a copy of a complete installation and maintenance bulletin, contact Armstrong International.

Caution

Do not use channel locks or pipe wrenches on the clear polysulfone body!
Hand Tighten Only!

The polysulfone body is sensitive to certain liquids. Reference the Polysulfone Chemical Resistance Chart below to determine if your operating environment is compatible with the 1AVC's body material.

Maximum Allowable Pressure (vessel design)
 150 psig @ 150 °F 10 bar @ 65 °C

Polysulfone Chemical Resistance Chart Applied Load 150 psig (10 bar)			
Environment	Concentration %	Ratings at Temperature	
		72°F (22°C)	140°F (60°C)
Automotive Products			
ASTM Oil #1	100	—	500 hours
ASTM Oil #2		24 hours	24 hours
ASTM Oil #3		24 hours	500 hours
Motor Oil #10		500 hours	—
Grease		500 hours	
Brake Fluid (Allstate)		R 1 hour	
Prestone (Anti-freeze)		500 hours	
Gasoline (Sunoco 2000)		C 70 hours	
Gasoline (Amoco)		R 2 hours	
Organic Chemicals: (Ketones, Chlorinated & Aromatic Hydrocarbons)			
Acetic Acid	20	500 hours	—
Oleic Acid	100		
Ethanol			
n-Heptone			
Ethyl Acetate			
Acetone			
Acetone / Water			
Methyl Ethyl Ketone (MEK)	100	R < 2 hours	
MEK / Water	20% MEK / 40% MEK	> 24 hours	
Toluene	100	R < 2 hours	
Toluene / Water	.05% Toluene	C < 2 hours	
Carbon Tetrachloride	100	CR < 1 hour	
1,1,1, -Trichloroethane	0.05	R < .01 hour	
2-Ethoxyethano (cellosolve)	100	C < 24 hours	
VM & P Naptha		> 24 hours	
Linseed Oil		500 hours	
Turpentine		R 15 hours	
Napthalene		Vapors	> 24 hours
Inorganic Chemicals			
Sulfuric Acid	10	500 hours	—
Hydrochloric Acid	20		
Sodium Hydroxide	50		
Ammonia	29		
Sodium Hypochlorite (Clorox)	5.25		

Key to ratings: Number indicates hours under stress. Letter (C=crazing; CR = cracks; R = rupture) indicates effect. No letter indicates test terminated with no adverse affects. **Chemical resistance data given in this chart should only be used as a guide, consult Armstrong International for further information.**

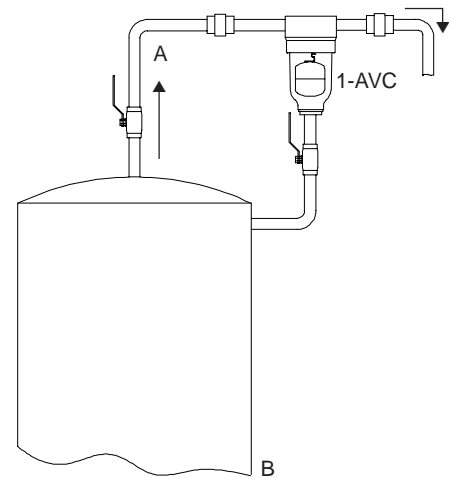

Figure 1. Continuous venting with an equalizing line where large amounts of air must be vented. As air enters Line A, water leaves through Line B. **Note:** Remove plug from cap in this installation.

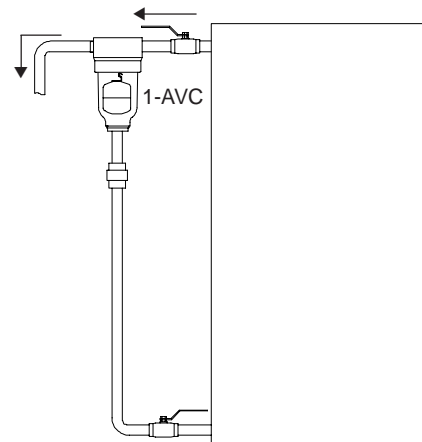

Figure 2. Automatic air vent discharging surplus air from water storage tank. **Note:** Remove plug from cap in this installation.

Typical Installations

Model 1LDC Air Vent

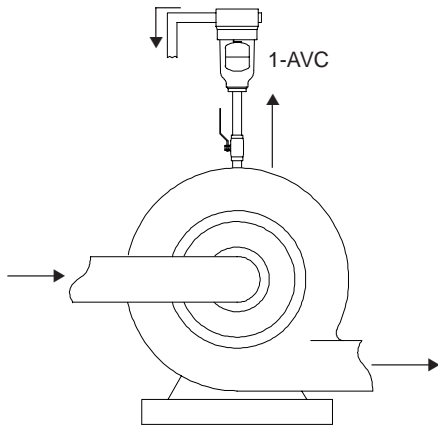

Figure 3
Automatic air vent on centrifugal pump. A full ported 3/4" valve and pipe must be used.

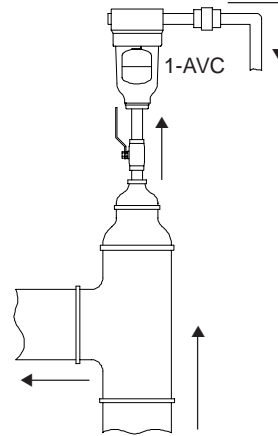

Figure 4
Automatic air vent on high point in system. A full ported 3/4" valve and pipe must be used.

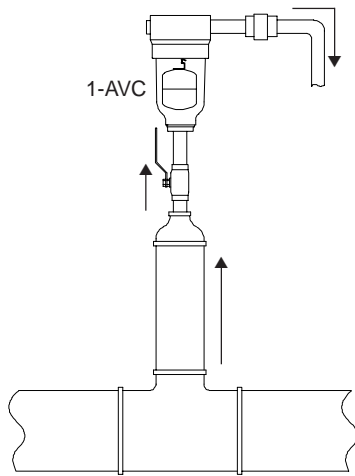

Figure 5
Automatic air vent on piping. A full ported 3/4" valve and pipe must be used.

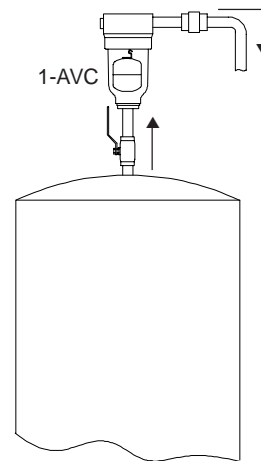

Figure 6
Automatic air vent on high point of tank. A full ported 3/4" valve and pipe must be used.

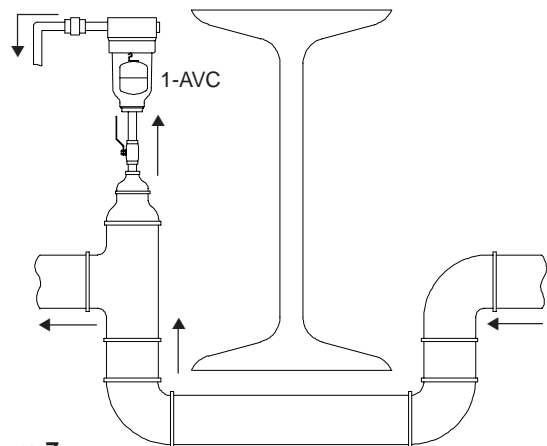

Figure 7
Automatic air vent on loop in piping. A full ported 3/4" valve and pipe must be used.



Armstrong International, Inc.

816 Maple Street, P.O. Box 408, Three Rivers, Michigan 49093 - USA Phone: (616) 273-1415 Fax: (616) 278-6555

Parc Industriel Des Hauts-Sarts, B-4040 Herstal/Liege, Belgium Phone: (32)(42) 409090 Fax: (32)(42) 2481361