

## THREE-WAY DIVERTING CONTROL VALVES $\text{CE}$

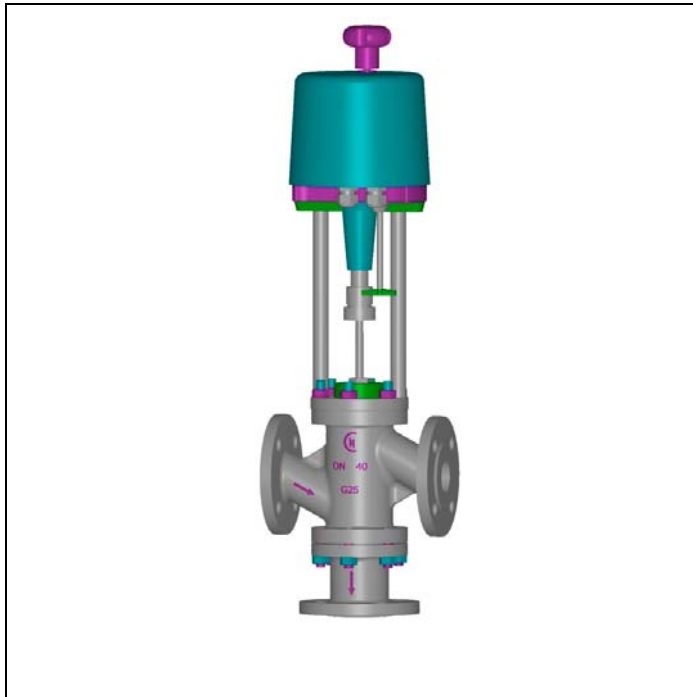

**TYPE 5700 EP** DN 15 – 100  
with tension opens and closes AB and AC

Face-to-face ASME / ANSI B16.10

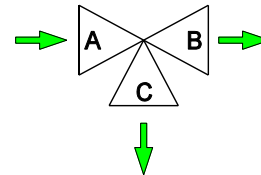

### DESCRIPTION

The "UNIWORLD" series type 5700 EP are equipped with "straight-through" pattern bodies having ANSI face-to-face dimensions and EN – ANSI – JIS flanges.

Type 5700 EP three-way diverting control valves (one inlet port and two outlet ports with fluid opens) have a modulating plug suitable for control of virtually all line media.

Compact construction assembled with "made in Germany" linear electric actuator fixed to the body by means of two steel columns.

The electric actuator works with standard 3 points modulating control signal or can be equipped with a potentiometer and with a pilot positioner having 0 (4) - 20 mA or 0 (2) - 10 V control signal.

**SIZES :** from DN 15 to DN 100

**BODY CONNECTIONS :** flanged EN 1092-1 PN16 PN40  
flanged ANSI B 16.5 150 RF 300 RF  
flanged JIS B2220 10K 20K

**MATERIALS OF BODY GROUP (1) :**

- Cast iron EN-GJL-250 UNI EN 1561 PN 16 ANSI 150 JIS10  
AISI 316 st. st. trim - C40 nickel plated steel bonnet
- Carbon steel ASTM A216 WCB PN16/40 ANSI 150/300 JIS10/20  
AISI 316 st. st. trim - C40 nickel plated steel bonnet
- Stainless steel AISI 316 CF8M PN16/40 ANSI 150/300 JIS10/20  
AISI 316 st. st. trim - AISI 316 st. st. bonnet

**PLUG**

- PL (DN15-20) LV (DN25-200) = linear class IV°
- PT (DN15-20) VPT (DN25-200) = quick lift class IV°

**BONNET (2) :**

- Standard : -5 to +200 °C
- Finned : > 200 °C
- Extended : below -5 °C
- Bellows sealed : for thermal oil or hazardous media with standard safety gland arrangement (PN 16 - 25 - 40)

**GLAND ARRANGEMENT (PACKING) (3) with safety "0-rings" :**

- PTFE 100% for temperatures  $\leq 150$  °C
- PTFE 85% + GRAPHITE 15% for temperatures  $\leq 200$  °C
- PURE GRAPHITE 100% for temperatures from 200° to 400 °C to be used with finned bonnet

**CV = american unit (flowrate in USGPM with 1 psi of differential pressure)**

**TECHNICAL CHARACTERISTICS OF ELECTRIC ACTUATOR :**

- Standard power supply : 220 V AC
- Degree of protection : IP 65 DIN 40050
- Control signal : 3 points modulating input
- Ambient temperature : -20 ... +60 °C
- Actuator case material : die cast aluminium
- Actuator cover material : polycarbonate
- Manual handwheel : standard included
- Electric connections : cable gland PG13 (2 off)

**MAX WORKING CONDITIONS :**

- Max inlet pressure and temperature : see leaflet n° 101/VP
- Valve sizing : see leaflet n° 100/VP
- Rangeability : see leaflet n° GRAFICI/I

**ON REQUEST :**

- Lapping on seat and plug class V°
- Stellite (degree 6°) on seat and plug
- Stellite (degree 6°) on guide bush
- Power supply 24 V CC (PSL201-202-204-210) – 24 V AC – 110 V AC
- Potentiometer 1000 Ohm, simple or double
- Positioner 0 (4)–20 mA ... 0 (2)–10 V, 2 wires, c/w potentiometer
- Card with mechanical limit switches
- Card for 4-20 mA feedback signal (2 wires system)
- IP 67 DIN 40050 protection
- Heating resistor for ambient temperature up-to - 30 °C
- Lubrificator for finned bonnet for temperature  $\geq 250$ °C

**Kv = metric unit (flowrate in m3/h with 1 bar of differential pressure)**

PLUG		DN15	DN 20	DN25	DN32	DN40	DN50	DN65	DN80	DN100
		$\varnothing$ 1/2"	$\varnothing$ 3/4"	$\varnothing$ 1"	$\varnothing$ 1.1/4"	$\varnothing$ 1.1/2"	$\varnothing$ 2"	$\varnothing$ 2.1/2"	$\varnothing$ 3"	$\varnothing$ 4"
LV	CV	3.4	6.6	10	23.4	28	36.4	72.7	89.3	123.8
	KV	2.9	5.7	8.6	20.1	24.1	31.4	62.7	77.0	106.7
PT	CV	3.4	6.6	13.8	30.3	38.7	52	107.3	129.3	175.4
	KV	2.9	5.7	11.9	26.1	33.4	44.8	92.5	111.5	151.2
Reduced bore *		n.a.	1/2"	3/4"	1"	1.1/4"	1.1/2"	2"	2.1/2"	3"

n.a. = not applicable

\* CV and KV values are referred to the selected diameter and plug type (PL/LV only)

**Maximum permissible pressure drops in Kg/cm<sup>2</sup> (fluid opens) with alive motor  
Power and Current absorbed – Speed in second for total stroke in mm**

Actuator Type Power absorbed		NOMINAL DIAMETER								
		DN15	DN20	DN25	DN32	DN40	DN50	DN65	DN80	DN100
PSL201 50/60 Hz 26 VA	Kg/cm <sup>2</sup>	50	31	18	12	8	4.5	-	-	-
	velocità sec	44	44	44	76	76	76	-	-	-
	corsa mm	11	11	11	19	19	19	-	-	-
PSL202 50/60 Hz 37/40 VA	Kg/cm <sup>2</sup>	-	62	36	24	16	9	6	4	2.2
	velocità sec	-	22	22	38	38	38	56	56	56
	corsa mm	-	11	11	19	19	19	28	28	28
PSL204 50/60 Hz 44/47 VA	Kg/cm <sup>2</sup>	-	-	85	55	38	22	13.5	9.4	5.3
	velocità sec	-	-	22	38	38	38	56	56	56
	corsa mm	-	-	11	19	19	19	28	28	28
PSL210 50/60 Hz 72/68 VA	Kg/cm <sup>2</sup>	-	-	-	-	94	54	33.5	23.5	13
	velocità sec	-	-	-	-	38	57	84	84	84
	corsa mm	-	-	-	-	19	19	28	28	28

- The values given are referred to the force of the actuator and they can be used within the limit of the body rating.
- Electric actuators suitable for operating force up-to 25 kN are available on request.

**COMPONENTS LIST and MATERIALS**

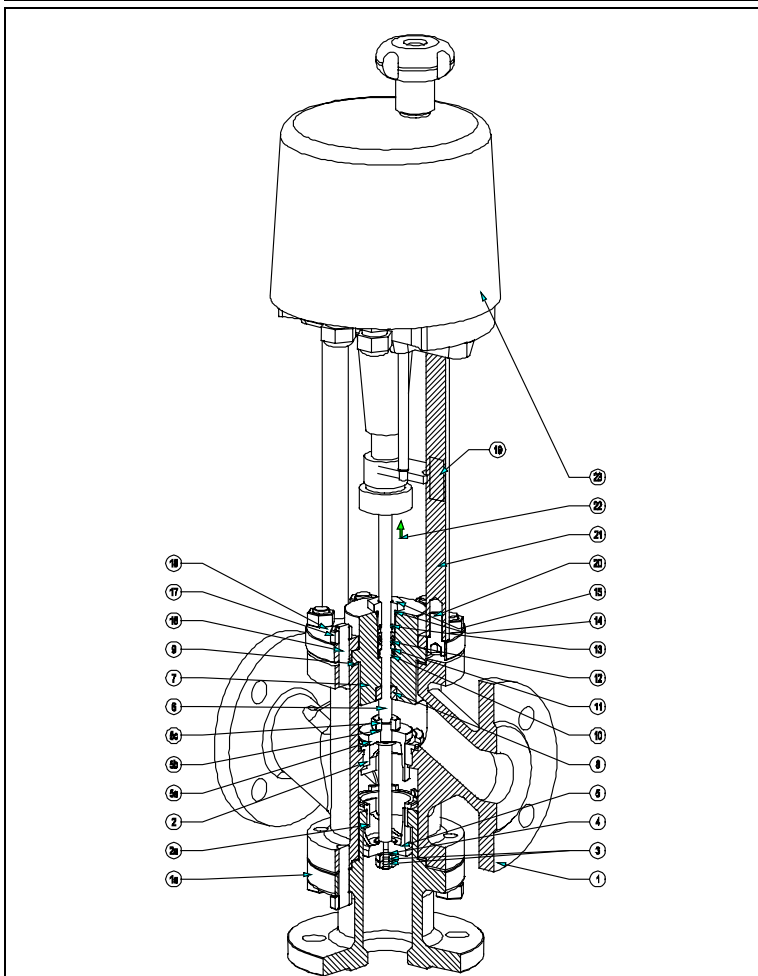

**COMPONENTS LIST**

- Body
- Stud pipe
- Upper seat
- Lower seat
- Lower plug locknuts
- Lower spring washer
- Lower plug
- Upper plug
- Upper spring washer
- Upper plug locknuts
- Stem
- Bonnet
- Guide bush
- Body gasket
- Packing spring
- Packing washer
- Packing rings
- Internal "O" ring
- External "O"
- Packing adjusting nut
- Stud-bolts
- Body locknuts
- Upper bonnet flange
- Travel indicator plate
- Column fixing screws
- Actuator columns
- Grub screw
- Electric actuator

**MATERIALS**

- See note (1) at page 1
- C40 carbon steel
- AISI 316 stainless steel
- AISI 316 stainless steel
- AISI 304 stainless steel
- AISI 304 stainless steel
- AISI 316 stainless steel
- AISI 316 stainless steel
- AISI 304 stainless steel
- AISI 304 stainless steel
- AISI 316 stainless steel
- See notes (1)(2) at page 1
- AISI 304 stainless steel
- Europil WS 3640 or PTFE on request
- AISI 302 stainless steel
- AISI 304 stainless steel
- See note (3) at page 1
- Viton FPM 70
- Viton FPM 70
- AISI 303 stainless steel
- Galvanized steel
- DIN 934 galvanized steel
- C40 nickel plated steel
- Polycarbonate
- DIN 912 galvanized steel
- AISI 430 stainless steel
- DIN 914 galvanized steel
- See technical data at page 1

**DIMENSIONS in mm.**

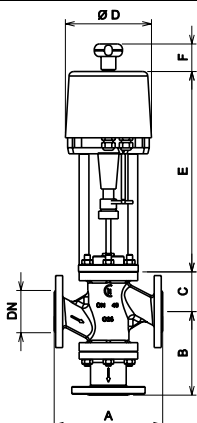

**BODY GROUP**

**ACTUATOR**

DN	Ø	A(1)	A(2)	B	C - Bonnet			PSL201-202-204-210		
					Std	Finned	Bellows	Ø D	E	F
15	1/2"	184	196	132	49	181	181	176	410	50
20	3/4"	184	196	134	58	190	190	176	410	50
25	1"	184	196	135	68	200	200	176	410	50
32	1.1/4"	200	212	134	70	202	202	176	410	50
40	1.1/2"	222	234	165	82	214	214	176	410	50
50	2"	254	266	185	86	218	218	176	410	50
65	2.1/2"	276	292	220	111	309	309	176	417	50
80	3"	298	317	222	135	333	333	176	417	50
100	4"	352	368	241	160	363	363	176	419	50

- A(1) cast iron = PN16 – ANSI150 – JIS10K  
 A(2) carbon and st. steel = PN16 – PN40 - ANSI150 – ANSI300  
 JIS10K – JIS20K

Specifications given are only indicative and not binding for the manufacturer who reserve the right to carry-out any modification deemed necessary without prior notice

## THREE-WAY DIVERTING CONTROL VALVES CE



**TYPE 5700 EP** DN 125 - 200  
with tension opens and closes AB e AC

Face-to-face ASME / ANSI B16.10

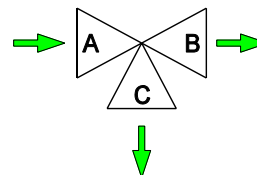

### DESCRIPTION

The "UNIWORLD" series type 5700 EP are equipped with "straight-through" pattern bodies having ANSI face-to-face dimensions and EN - ANSI - JIS flanges.

Type 5700 EP three-way diverting control valves (one inlet port and two outlet ports with fluid opens) have a modulating plug suitable for control of virtually all line media.

Compact construction assembled with "made in Germany" linear electric actuator fixed to the body by means of two steel columns.

The electric actuator works with standard 3 points modulating control signal or can be equipped with a potentiometer and with a pilot positioner having 0 (4) - 20 mA or 0 (2) - 10 V control signal.

**SIZES :** from DN 125 to DN 200

**BODY CONNECTIONS :** flanged EN 1092-1 PN16 PN40  
flanged ANSI B 16.5 150 RF 300 RF  
flanged JIS B2220 10K 20K

#### MATERIALS OF BODY GROUP (1) :

- **Cast iron EN-GJL-250 UNI EN 1561 PN 16 ANSI 150 JIS10**  
AISI 316 st. st. trim - C40 nickel plated steel bonnet
- **Carbon steel ASTM A216 WCB PN16/40 ANSI 150/300 JIS10/20**  
AISI 316 st. st. trim - C40 nickel plated steel bonnet
- **Stainless steel AISI 316 CF8M PN16/40 ANSI 150/300 JIS10/20**  
AISI 316 st. st. trim - AISI 316 st. st. bonnet

#### PLUGS :

- **LV** = linear class IV°
- **LVPT** = quick lift cl. IV°

#### BONNET (2) :

- Standard : -5 to + 200 °C
- Finned : > 200 °C
- Extended : below - 5 °C
- Bellows sealed : for thermal oil or hazardous media with standard safety gland arrangement (PN 16 - 25 - 40)

#### GLAND ARRANGEMENT (PACKING) (3) with safety "O-rings" :

- PTFE 100% for temperatures ≤ 150 °C
- PTFE 85% + GRAPHITE 15% for temperatures ≤ 200 °C
- PURE GRAPHITE 100% for temperatures from 200° to 400 °C to be used with finned bonnet

**CV = american unit (flowrate in USGPM with 1 psi of differential pressure)**

#### TECHNICAL CHARACTERISTICS OF ELECTRIC ACTUATOR :

- Standard power supply : 220 V AC
- Degree of protection : IP 65 DIN 40050
- Control signal : 3 points modulating input
- Ambient temperature : -20 ... +60 °C
- Actuator case material : die cast aluminium
- Actuator cover material : polycarbonate
- Manual handwheel : standard included
- Electric connections : cable gland PG13 (2 off)

#### MAX WORKING CONDITIONS :

- Max inlet pressure and temperature : see leaflet n° 101/VP
- Valve sizing : see leaflet n° 100/VP
- Rangeability : see leaflet n° GRAFICI/I

#### ON REQUEST :

- Lapping on seat and plug class V°
- Stellite (degree 6°) on seat and plug
- Stellite (degree 6°) on guide bush
- Power supply 24 V CC (PSL201-202-204-210) - 24 V AC - 110 V AC
- Potentiometer 1000 Ohm, simple or double
- Positioner 0 (4)-20 mA ... 0 (2)-10 V, 2 wires, c/w potentiometer
- Card with mechanical limit switches
- Card for 4-20 mA feedback signal (2 wires system)
- IP 67 DIN 40050 protection
- Heating resistor for ambient temperature up-to - 30 °C
- Lubrificator for finned bonnet for temperature ≥ 250°C

**Kv = metric unit (flowrate in m3/h with 1 bar of differential pressure)**

PLUG		DN 125		DN 150		DN200	
Full bore		Ø 5"		Ø 6"		Ø 8"	
LV	CV	290.9		357.3		578.1	
	KV	250.8		308		498.3	
LVPT	CV	355.3		429.8		658.6	
	KV	306.3		370.5		567.7	
Reduced bore *		3"	4"	4"	5"	5"	6"

\* CV and KV values are referred to the selected diameter and plug type (PL/LV only)

**Maximum permissible pressure drops in Kg/cm<sup>2</sup> (fluid opens) with alive motor  
Power and Current absorbed – Speed in second for total stroke in mm**

Actuator Type Power absorbed		NOMINAL DIAMETER		
		DN125	DN150	DN200
PSL312 50/60 Hz 88/73 VA	Kg/cm <sup>2</sup>	9.5	6.5	3.8
	speed sec	84	84	84
	stroke mm	50	50	50

- The values given are referred to the force of the actuator and they can be used within the limit of the body rating.
- Electric actuators suitable for operating force up-to 25 kN are available on request.

**COMPONENTS LIST and MATERIALS**

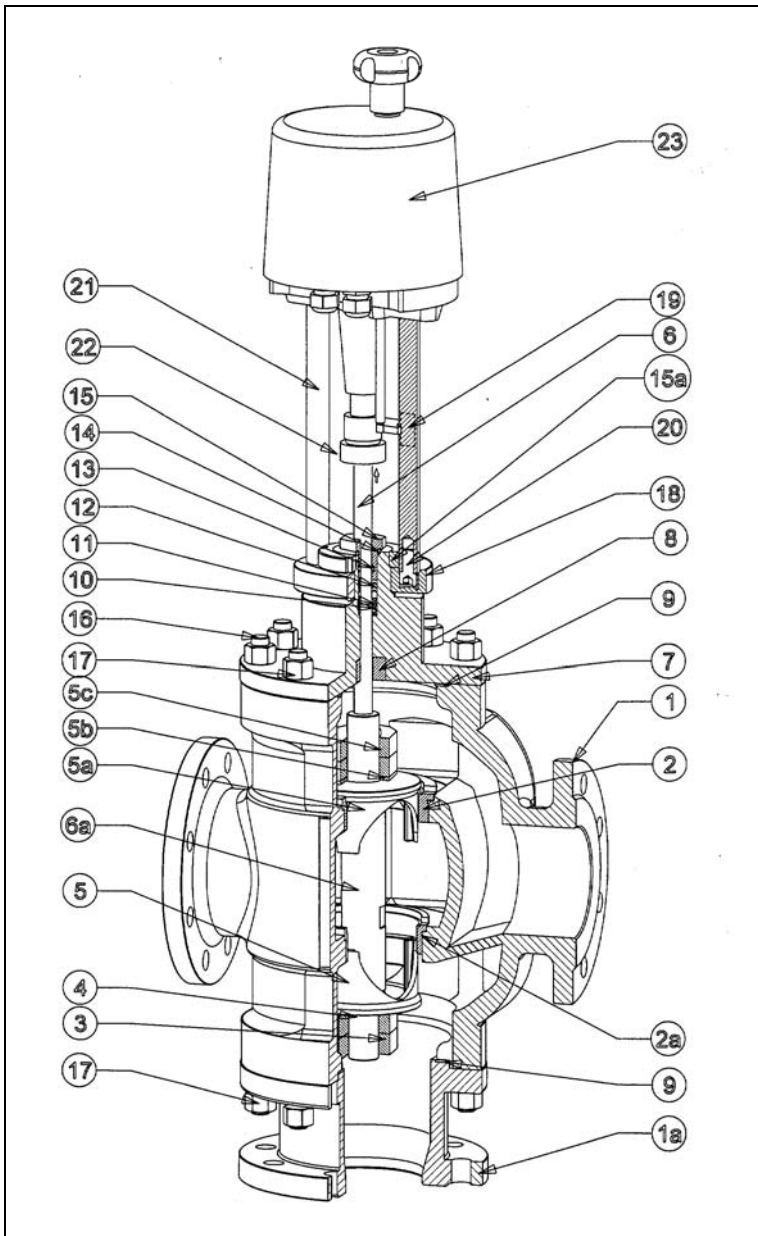

**COMPONENTS LIST**

- Body
- Upper seat
- Lower seat
- Lower spring washer
- Lower plug
- Upper plug
- Upper spring washer
- Upper plug locknuts
- Stem
- Plug shaft
- Bonnet
- Guide bush
- Body gasket
- Packing spring
- Packing washer
- Packing rings
- Internal "O" ring
- External "O"
- Packing adjusting nut
- Stud-bolts
- Body locknuts
- Upper bonnet flange
- Travel indicator plate
- Column fixing screws
- Actuator columns
- Grub screw
- Electric actuator

**MATERIALS**

- See note (1) at page 1
- C40 carbon steel
- AISI 316 stainless steel
- AISI 304 stainless steel
- AISI 304 stainless steel
- AISI 316 stainless steel
- AISI 304 stainless steel
- AISI 304 stainless steel
- AISI 316 stainless steel
- AISI 302 stainless steel
- AISI 304 stainless steel
- See note (3) at page 1
- Viton FPM 70
- Viton FPM 70
- AISI 303 stainless steel
- Galvanized steel
- DIN 934 galvanized steel
- C40 nickel plated steel
- Polycarbonate
- DIN 912 galvanized steel
- AISI 430 stainless steel
- DIN 914 galvanized steel
- See technical data at page 1

**DIMENSIONS in mm.**

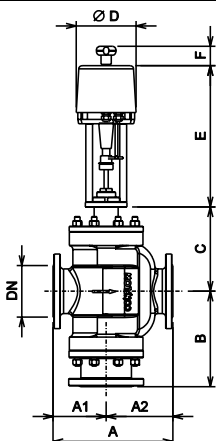

BODY GROUP						ACTUATOR					
DN	Ø	A	A1	A2	B	C - Bonnet			PSL 312		
						Std	Finned	Bellows	Ø D	E	F
125	5"	425	186	239	344	252	435	435	226	530	50
150	6"	473	206	267	375	258	442	442	226	530	50
200	8"	568	234	334	430	283	465	465	226	530	50

A(1) cast iron = PN16 – ANSI150 – JIS10K  
 A(2) carbon and st. steel = PN16 – PN40 - ANSI150 – ANSI300  
 JIS10K – JIS20K

Specifications given are only indicative and not binding for the manufacturer who reserve the right to carry-out any modification deemed necessary without prior notice