

FLOWSEAL

Butterfly Valves Series HP/DIN

Operation Manual

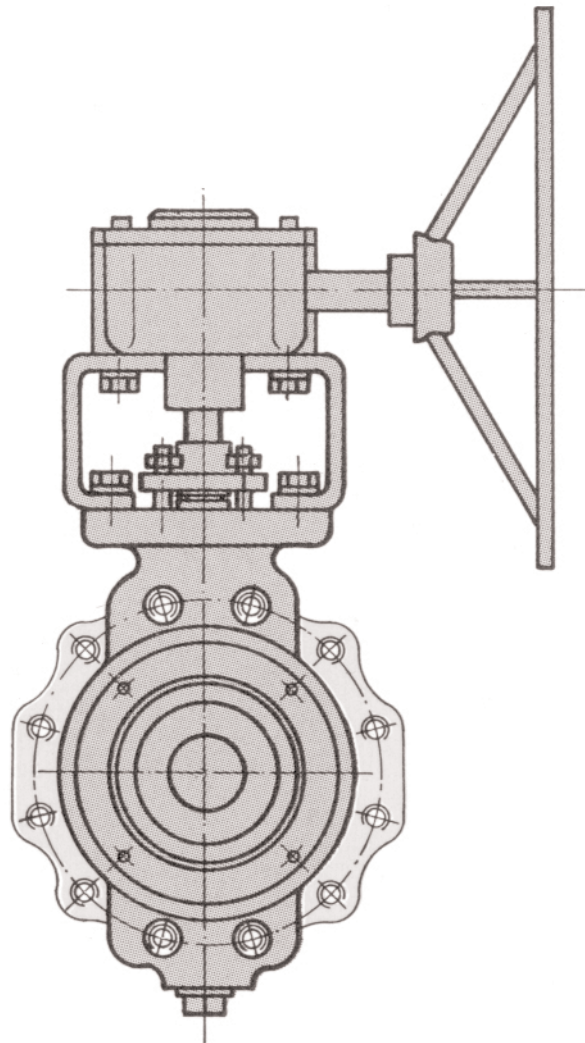

CRANE[®]

Table of contents

0	Introduction
1	Intended use
2	Safety notes
2.1	General safety notes
2.2	Safety notes for the operator instructions
2.3	Special types of danger
2.4	Marking of th valve
3	Transport and storage
4	Installation into the piping
4.1	General instructions
4.2	Working steps
5	Pressure test of the piping section
6	Normal operation and maintenance
7	Help with faults

0 Introduction

These instructions are to support the user with installation, operation and maintenance of valves.

 Caution	<p>If the subsequent caution- and warning comments are not adhered to, danger can result thereof and the guarantee of the manufacturer becomes null and void</p> <p>The manufacturer is at your disposal for further requests, for addresses see last page.</p>
---	--

1 Intended use

Butterfly valves of the series HP/DIN are only intended to lock, pass through or control the flow, after the installation into a pipeline system between the flanges PN 10 to PN 40 and after the set-up of the manual operating possibility or after the connection of the actuator to the control media within the permissible pressure- and temperature limits. These butterfly valves are not recommended for media with a high portion of abrasive solid materials.

The permitted pressure- and temperature range is described in the Crane data sheets <Flowseal butterfly Valves Series HP/DIN>.

 Caution	<p>If a valve with differential pressures larger than approx. 0.15 bar (liquid media) is used for the controlling in the continuous operation, the system limits are to be agreed upon with the manufacturer.</p>
---	---

2 Safety notes

2.1 General safety notes

The same safety regulations apply for valves as for the piping system in which they are installed and as for the control system to which the actuator is connected. The instructions available provide only such safety notes which are to be observed additionally for valves.

For actuator units additionally safety notes are contained in the respective operating instructions.

2.2 Safety notes for the operator instructions.

It is not within the responsibility of the manufacturer, and thus when using the valve, to ensure that

- the valve is used as intended in such a way as described in the Section 1,

 Danger	<p>Safeguard against improper use of the valve:</p> <p>It must be particularly ensured that the selected materials of the wetted parts of the valve are suitable for the used media.</p> <p>Ignorance of these precautionary measures can mean danger for life and limb and cause damage in the piping system.</p>
--	--

- An actuator or a manual operating possibility which has been installed subsequently onto the valve, and adjusted to the valve is adjusted correctly in both end positions of the valve.
- The piping system and the control system were assembled professionally and are checked regularly. The wall thickness of the body of the valve is dimensioned in such a way that in such professionally assembled lines the usual piping-additional forces and -moments are taken into account.
- The valve is connected professionally to these systems.
- In this piping system the usual flow speeds are not exceeded in the continuous operation, and abnormal operation conditions such as oscillations, water shocks, cavitation and larger portions of solid materials in the medium – in particular abrasive – are to be agreed upon with the manufacturer.
- Valves which are operated at operating temperatures >50°C or < -20°C are protected together with the piping connections against being touched.
- Only for pressure-conducting pipelines, qualified employee operates, services and repairs the valve.
- No marking according to directive 94/9/EG (ATEX)

This valves were examined in the scope of the directive 94/9/EG regarding of an assessment of danger of ignition in accordance with DIN EN 13463-1 2002.

The valves exhibit no own potential ignition sources and do not fall thus under the requirements of the directive. A CE marking following this directive is not permissible. The valves can be used in a potentially explosive area.

2.3 Special types of danger

 Danger to life	<p>The flap shaft is sealed by a compression gland. Before the nuts are loosened at the gland, the pressure in the pipeline must be completely diminished, so that no media escapes from the compression gland.</p>
--	--

 Danger to life	<p>Before loosening the screw connection (or the cover) at the body or before dismantling the valve from the pipeline, the pressure in the pipeline must be completely diminished, so that the media does not escape unchecked from the line.</p>
--	--

 Danger	<p><i>For valves, which are used as end valve:</i></p> <p>During normal use, in particular with gas-like, hot and/or dangerous media a blind flange must be mounted at the free connecting pieces or the valve must be securely locked in „CLOSE“-position.</p>
--	--

 Danger	<p>If a valve has to be opened as end valve in a pressure containing line, this may take place with all caution only in such a way that the spurting media does not cause any damage.</p>
--	--

 Danger	<p>If a valve must be disassembled from a pipeline, media can escape from the line or from the valve. With unhealthy or dangerous media the pipeline must be completely emptied before the valve is disassembled. Caution with residues which reflow from the line or which have remained in body cavities of the valve (under pressure).</p>
--	--



2.4 Marking of the valve

We mark the valve according to EN 19 or on customer request. Markings may not be damaged, that the valve can be identified.

3 Transport and storage

Valves must be treated, transported and stored carefully:





- The valve is to be stored in its protective package and/or with the protective caps at the connection ends. Valves which are heavier than approx. 10 kg, should be stored and transported on a pallet (or similar supported) (also to the installation place).
- With storage before installation, valve, gear and actuator are to be protected from damaging influences such as dirt or humidity and are to be stored at ambient temperature.
- Particularly the actuator, the gear and the ends of the valve to the piping connection may neither be damaged through mechanical nor other influences.
- Valves must be stored in such a way as they were supplied. The operating device may not be activated.

 Danger	<i>Only valves, which are supplied with free shaft end:</i> The valve must be transported with the utmost care: the unsecured flap disk can open by itself out of the locking position due to effect from outside.
 Caution	<i>Only valves with actuator type „safety position „OPEN“</i> In the delivery state the flap disk protrudes on both sides from the body. The protruding rim of the flap disk has to be protected against damage: If the packing surface at the disk rim is damaged, the butterfly valve is no longer leak-proof!

4 Installation into the piping

4.1 General instructions

For the installation of valves into a piping, the same instructions apply as for the connection of pipes and similar piping elements. For valves, the subsequent instructions apply additionally. For the transport to the installation place also the Section 3 (above) is to be considered.

 Caution	The packing surfaces at the body of the butterfly valve are constructed in such a way that the flange sealings are to be used in accordance with EN1514-1 or ANSI B16.21. Counter flanges must have smooth packing strips, e.g. form A or B according to standard EN 1092. Other flange forms are to be agreed with the manufacturer.
 Danger	<i>In order to avoid leakage at the flange connection:</i> Only suitable flange sealings may be used for the flange connections. Flange sealings made of elastomer may not be used.
 Danger	<i>The actuator is adjusted for the operating data indicated in the order:</i> The adjustment of the final impacts „OPEN“ and „CLOSE“ may not be changed without agreement of the manufacturer.
 Danger to life	If – in special circumstances – a valve must be mounted without operating possibility, it is to be ensured that such a valve is not pressurized. If an actuator unit is retrofitted, torque, rotation direction, operating angle and the adjustment of the final impacts „OPEN“ and „CLOSE“ must be adapted to the valve. Ignorance of these precautionary measures can mean danger for life and limb and cause damage in the piping system.
 Caution	<i>Only for valves with electric actuator:</i> It is to be ensured that the valve in the „CLOSE“-position is switched off by the signal of the torque switch . In the position „OPEN“ the flap must be switched off with the signal of the limit switch . <i>For further information, see the operating instructions of the electric drive.</i>

4.2 Working steps

- Transport valve in the protective package to the installation place and remove it only there.
- Examine valve, gear and actuator for transport damage. Damaged units may not be installed.
- Ensure that only valves are installed whose pressure class, type of connection and connection dimensions correspond to the application conditions. The connection data for the actuator must correspond with the data of the control. See labelling at the actuator.

 Danger to life	No valve may be installed whose approved pressure-/temperature range („Rating“) is not sufficient for the operating condition. This approved range is described in the technical Crane-data sheet HP-C8/DB-0008-D01.03 Ignoring these regulations could mean danger for life and limb and cause damage to the piping system. In the case of doubt the manufacturer is to be consulted.
--	--

- The counter flanges of the piping must align and be parallel to the plane. They must have a clearance which leaves sufficient place for the opened flap disk, so that the flap disk is not damaged when swivelling out.
- Before the installation, the valve and the subsequent piping must be cleaned carefully of dirt, in particular from hard foreign substances.

 Danger	<i>Only butterfly valves with actuator „Safety position OPEN“:</i> For the installation the opened flap disc with control media must be closed and inserted into the line in completely closed state and bolted. It must be ensured that for this installation process a supply with control media is available with full actuating pressure for the closing of the butterfly valve.
--	--

- Butterfly valves of the series HP/DIN can be installed generally independently from the flow direction. In order to protect the seat ring:
- It is recommended to install the valve in such a way that a direction of arrow marked at the body (if available) corresponds with the flow direction.
- The preferred installation position is the one with horizontal flap shaft. The actuator is however to be arranged – if possible– not directly underneath the valve: Compression gland sealings can damage the actuator.

- When inserting the valve (and the necessary sealings) in an already mounted pipeline the distance between the piping ends must be dimensioned in such a way that all connection- and/or sealing surfaces (and sealings) remain undamaged.

 Caution	The valve must be inserted with closed flap disk into the gap between the pipeline ends: Otherwise the flap disk could be damaged and the valve becomes no longer leak-proof.
---	---

- The butterfly valve is to be centred when installing by means of the flange screws.

 Caution	Butterfly valves series HP/DIN need screws of partly different lengths for the connection to the counter flanges.
---	---

- The torque for tightening the flange screws must be adapted as usual to the used flange sealing and the operation conditions.
- For the connection of the actuator unit to the control, the appropriate instructions apply.
- For the termination of the installation a functional test with the signals of the control is to be executed with the actuated valves: The valve must close and open correctly according to the control commands. Detectable functioning faults are absolutely to be remedied before the commissioning. See also Section 7 <Help with faults>.

 Danger	Faulty executed control commands could mean danger for life and limb and cause damage to the piping system.
--	--

5 Pressure test of the piping section

For the pressure test of the valves the same instructions apply as for the piping. Additionally applies:



- Rinse new installed line systems carefully in order to wash out foreign substances.
- The pressure test of an opened valve may not exceed the value 1,5 x PN/PS.
- A closed valve may be tested under pressure PT only with 1,1 x PN/PS (according to marking)

6 Normal operation and maintenance

The valves are to be operated manually or with the signals of the control. Valves which were supplied ex factory with actuator or gear are exactly adapted and may not be adjusted as long as a valve operates perfectly.

For the manual operation or the hand emergency operation at the actuator (if available) normal hand force is sufficient; the usage of extension for the increase of the actuation moment is not permissible.

For the manual operation or the hand emergency operation at the actuator (if available) normal hand force is sufficient; the usage of extension for the increase of the actuation moment is not permissible. In such cases the Section 2 <Safety information> and Section 7 <Faults> are to be observed.

 Danger	A butterfly valve is not self-locking: The operating possibility may not be dismantled as long as the butterfly valve is pressurized.
 Danger	A butterfly valve is not self-locking: Piston drives need a constant supply with control pressure for all positions which are started up under control pressure.

7 Help with faults

With the remedying of faults the Section 2 <Safety notes> is absolutely to be adhered to.

Type of the fault	Measurement	Note
Leakage at the flange connection/locking screw or body cover	Retighten flange-/locking screws. <i>If the leakage cannot be remedied:</i> Repair is necessary: Replace sealing: Spare parts and necessary instructions are to be requested from Crane.	Note 1: Only original spare parts may be installed. Note 2: If it is detected after the disassembly that the wetted inner parts are not sufficiently resistant towards the medium, parts of suitable material are to be selected
Leakage in the seat sealing	Check whether the valve is closed 100%. If 100% closed and an actuator is mounted: Check whether the actuator closes with full torque. If actuator ok: Open and close valve several times under pressure. If the gear is mounted, readjust final impact: Readjust the impact „CLOSE“ in the actuator in such a way that the flap disk can move somewhat further to the „CLOSE“-position. If valve is then still leaky: Repair is necessary: Replace seat sealing, spare parts and necessary instructions are to be requested from Crane.	
Leakage at the compression gland	Retighten both nuts at the gland alternately and in steps of ¼ rotation each. If the leakage can not be remedied by this: Repair is necessary: Spare parts and necessary instructions are to be requested from Crane. If the nuts at the gland have to be loosened or unscrewed: Observe section 2.3 <Special dangers>.	
Malfunction	 Danger to life To safeguard the operating staff against danger, ensure that the line is completely depressurized beforehand. Check actuator unit and control commands. Dismantle valve (observe thereby the notes of Section 2.3 <Special dangers>) and inspect. If the valve is damaged: Repair is necessary: Spare parts and necessary instructions are to be requested from Crane.	

With faults at the actuator unit, see appropriate instructions.

**Declaration of conformity according directive 97/23 EC
Declaration of the manufacturer according directive 98/38 EC**

The manufacturer **XOMOX International GmbH & Co, D88131 Lindau/Bodensee** declares that the valves:

Butterfly valves series 600 and series 800 *
in accordance with XOMOX technical data sheets: tdb_800_gb, and tdb_600_gb
 · with pneumatic-/ electro-/ hydraulic actuator
 · with free shaft end for later installation of operating

1. pressure bearing accessories within the meaning of the EC pressure equipment directive 97/23 EC and which are in conformity with the requirements of this directive,
2. which are not complete machines within the meaning of the EEC machine directive 98/37 EC, but fulfill the relevant requirements of this directive,
3. may be operated only in compliance with the appropriate operating instruction.

*) identical construction as Flowseal Serie HP-DIN

<i>Applied standards:</i>	EN 593, Revision 2002 EN 292	Design standard flaps Safety of machines– part 2: Technical requirements
<i>Description of type and technical features:</i>		XOMOX technical data sheet: tdb_800_gb <high-performance-butterfly valves type 800> XOMOX technical data sheet: tdb_600_gb <high-performance butterfly valves type 600>
<i>Applied conformity-evaluation methods:</i>		in accordance with Annex II of the pressure equipment directive 97/23 EC
<i>Name of the designated places:</i>		TUV Süddeutschland Det Norske Veritas
<i>Identification number of the designated place:</i>		identification No. 0036), Module B + C1... (identification No. 0434), Module H

If not otherwise required by the costumer XOMOX classifies all valves as category 3, module H.

Modifications to valves and/or units, which have consequences for the technical data of the valve, for the<intentional use> according to Section 1 of the operating instructions, and which modify essentially the valve and/or a supplied unit, make these declarations invalid.

January 2002



Lindau/Bodensee, Date

E.Niessen, General Manager



A Crane Co. Company