

## PRODUCT DESCRIPTION

Wafer style, unidirectional knife gate valve with round to square flow pass.  
Cast body, composed by two bolted parts, with inside sliding guides to provide a smooth operation.  
High flow rates with low pressure drops.  
Several seat and packing materials available.  
Face to face dimension according CMO standard.

## GENERAL APPLICATIONS

This knife gate valve is appropriate for very abrasive and difficult applications where the valve can suffer a big damage.  
It is mainly used in paper recycling plants located in pulper junk traps and in general in places where hard particles (like metal clips and stones) are present in the media.

It is always installed in horizontal position and the difference in section from the inlet (round) to the outlet (square and bigger) allows to the solids to move free avoiding the jamming of the gate.

## TECHNICAL DATA

### Standard manufacturing sizes:

From DN50 up to DN800 (bigger sizes under request)

### Working pressures:

From DN 50 to DN 125: 10 (kg/cm<sup>2</sup>)  
DN 150: 8 (kg/cm<sup>2</sup>)  
DN 200: 7 (kg/cm<sup>2</sup>)  
From DN 250 to DN 300: 5 (kg/cm<sup>2</sup>)  
From DN 350 to DN 400: 4 (kg/cm<sup>2</sup>)  
From DN 450 to DN 600: 3 (kg/cm<sup>2</sup>)  
From DN 700 to DN 800: 2 (kg/cm<sup>2</sup>)

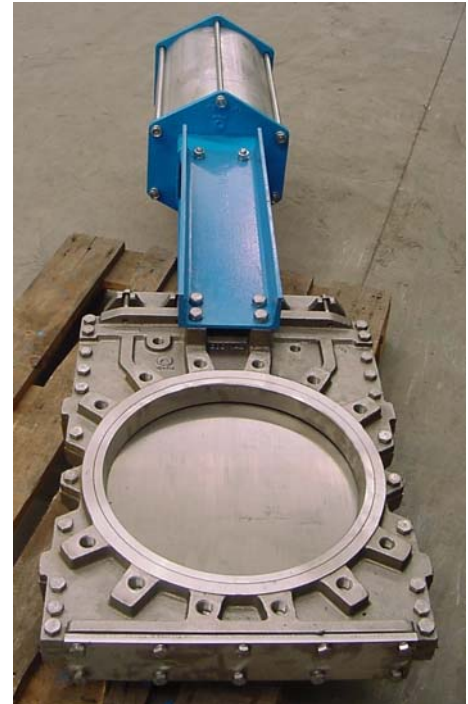

**Note:** These pressures could be applied either in one side or the other side of the valve because of its bidirectional body design but the valve is designed to work only in one direction flow.

### Flange connection drillings:

The standard flange connection is according to DIN PN10.

Other flange connections such as, ANSI 150, DIN PN6 – PN16 – PN25, British Standard, Australian Standard, JIS Standard, are available under request.

### Applied Directives:

Directive 98/37/CE (machinery), **Directive 97/23/CE (PED: Group 2)**, Directive 94/9/CE (ATEX: Group II, Cat. 3 / Zones 2 and 22)

**Quality Dossier:** All valves are hydrostatically tested at CMO with water and CMO material and test certificates can be provided.

Body test pressure = Maximum rated pressure x 1.5

Seat test pressure = Maximum rated pressure x 1.1

# KNIFE GATE VALVES – MODEL E

DOC. E.07/08

## ADVANTAGES OF CMO “MODEL E” COMPARING WITH SIMILAR PRODUCTS

The type E is manufactured with two body half design. The inside surface of the two bodies is machined and they are assembled with bolts creating a solid block.

The valve gate slides inside of the two body parts thanks to several RCH 1000 nylon sliding guides installed inside of the bodies. These sliding guides can be supplied in other materials like PTFE or brass.

Other manufacturers supply similar valves with fully PTFE lined internals, but when the valve is working with metal particles and other solids they stick on the PTFE lining and finally the gate is jammed.

This is one of the main advantages in comparison with other manufacturers.

The stem protection hood is independent from the hand wheel fixing system, so the hood can be removed without removing the hand wheel. This point allows normal maintenance operations like greasing of the spindle, etc.

The spindle (stem) of the CMO valve is made of stainless steel 18/8. This point is very important because there are manufacturers that manufacture it with 13% CR and it gets rusty in a very short time.

The hand wheel of the manual actuator is made of nodular iron GGG-50. Some manufacturers manufacture it on normal cast iron and they can break easily when receiving any big torque or knock.

The bridge of the CMO manual actuator is manufactured in a compact way, with the bronze nut protected in a greased and closed box. This point gives the possibility to move it with a key even without the hand wheel (in other manufacturer valves this is not possible).

The pneumatic actuator upper and lower caps are made of nodular iron GGG-50, therefore their resistance to the knocks is very high. This characteristic is essential in this type of pneumatic cylinder. Special care must be taken with cylinders with covers in aluminium or cast iron

The sealing o-rings of the pneumatic cylinders are commercial and they can be bought all over the world, it is not needed, therefore, to contact CMO every time that these spares are needed.

## STANDARD MANUFACTURING MATERIALS (OPTIONS 1 AND 2)

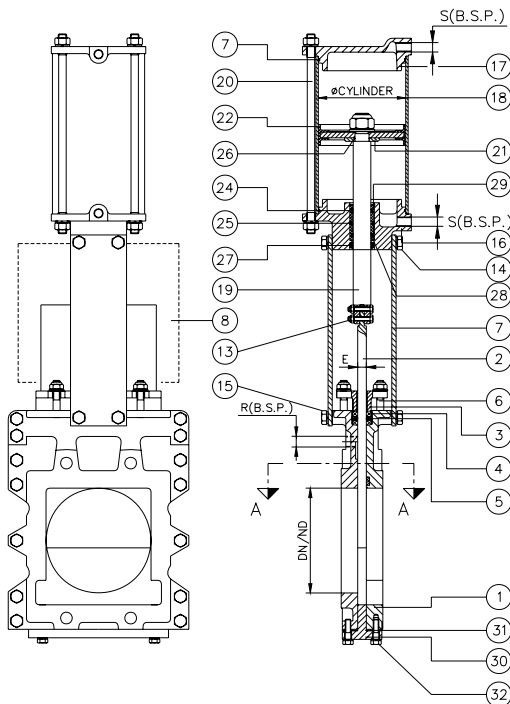

POS.	DESCRIPTION	OPTION 1	OPTION 2
1	BODY	GG25	CF8M
2	KNIFE	AISI304	AISI316
3	PACKING GLAND	ALUMINIUM	CF8M
4	PACKING	SYNT.+PTFE	SYNT.+PTFE
5	O-RING	EPDM	EPDM
6	STUD	STEEL+ZINC	AISI316
7	SUPPORT	STEEL	STEEL
8	SAFETY GUARDS (OPTIONAL)	STEEL	STEEL
9	JOINT	EPDM	EPDM
10	REINFORCED RING	CF8M	CF8M
11	SLIDES	-	RCH1000
12	SLIDES	-	RCH1000
13	BOLTS	AISI304	AISI316
14	BOLTS	STEEL	STEEL
15	BOLTS	STEEL	AISI316
16	CYLINDER HEAD	ALUMINIUM	ALUMINIUM
17	CYLINDER CAP	ALUMINIUM	ALUMINIUM
18	JACKET	ALUMINIUM	ALUMINIUM
19	PISTON ROD	AISI304	AISI304
20	TIE ROD	STEEL+ZINC	STEEL+ZINC
21	WASHER	STEEL	STEEL
22	PISTON	STEEL+NITRILE	STEEL+NITRILE
23	O-RING	NITRILE	NITRILE
24	O-RING	NITRILE	NITRILE
25	O-RING	NITRILE	NITRILE
26	O-RING	NITRILE	NITRILE
27	SCRAPER	STEEL+NITRILE	STEEL+NITRILE
28	GUIDE SLEEVE	NYLON	NYLON
29	ELASTIC RING	STEEL	STEEL
30	BOTTON	GG25	CF8M
31	JOINT	RUBBER	RUBBER
32	BOLTS	STEEL	AISI316

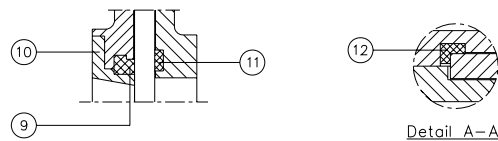

## DESIGN FEATURES IN DETAIL

### 1) BODY

Wafer style cast body with reinforcing ribs, composed by two bolted parts, with inside RCH1000 nylon sliding guides (other materials like PTFE or brass are also available) to provide a smooth operation.

The inside surface of the two bodies is machined and they are assembled with bolts creating a solid block.

The square outlet is bigger than the round inlet which allows to the solids to move free avoiding any building up on the seat area. At the same time this characteristic provides high flow rates and the pressure drop is minimal.

At the bottom of the body a closed cap is located that can be opened for cleaning operations and there are some points in the body where flushing holes can be installed to perform the same cleaning operation in the body internals.

For sizes bigger than DN800 the construction of the body is fabricated in carbon steel with reinforcement ribs to withstand the maximum rated pressure.

The standard manufacturing materials are GG25 cast iron and CF8M stainless steel. Other materials like GGG50 nodular cast iron, A216WCB carbon steel and stainless steel alloys (AISI316Ti, Duplex, 254SMO, Uranus B6 ....) under request. Cast iron or steel valves are painted as standard with 80 microns anticorrosive protection of EPOXY (colour RAL 5015). Other anticorrosive protections available under request.

### 2) GATE

Since the valve is designed for very abrasive applications it comes with an extra thicker gate as standard.

The standard manufacturing materials are AISI304 stainless steel for cast iron body valve and AISI316 stainless steel for CF8M stainless steel body valve. Other materials or combinations can be supplied under request.

The gate is polished in both sides to provide a smooth contact surface with the sealing joint. At the same time the gate wedge is rounded to avoid cutting of the sealing. Several polishing grades, anti abrasion treatments and modifications are available to adapt the valve to the customer requirements.

### 3) SEAT

The seat of valve is composed by a rubber sealing (normally EPDM) that is held to the valve body by a reinforced ring. The body of the valve is machined in the way that the reinforced ring can be inserted into the body.

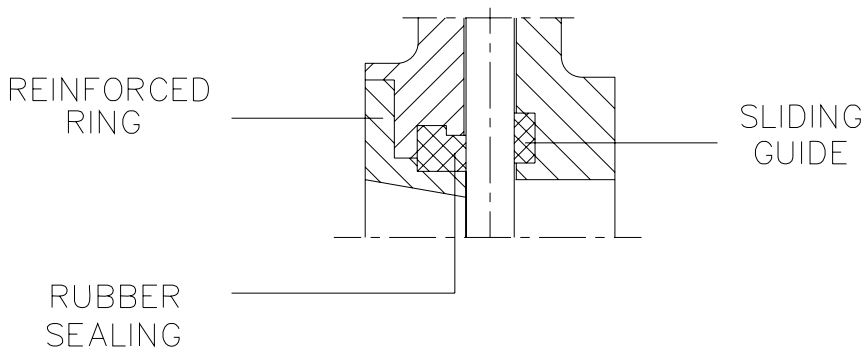

This design ensures a long lasting sealing on the valve and a perfect protection of the valve in front of aggressive applications.

At the same time it allows the changing of the sealing without opening the body parts because just losing the reinforced ring is possible to change the rubber sealing.



### Resilient Seat Materials

#### **EPDM**

This is the standard resilient seat installed on CMO valves. It can be used in many applications, but generally it is used for water and products diluted in water at temperatures not higher than 90°C. The EPDM rubber can also be used for abrasive products. It provides 100% tightness.

#### **NITRILE**

It is used for greasy fluids or oils at temperatures not higher than 90 °C. It provides 100% tightness.

#### **VITON**

Appropriate for corrosive products and high temperatures up to 190°C in continuous and peaks of 210°C. It provides 100% tightness.

#### **PTFE**

It is used for corrosive products and PH from 2 to 12. This sealing material does not provide 100% tightness. The estimated leakage is 0.5% of the total flow.

### **4) PACKING**

As standard the packing is composed by three lines with an EPDM o-ring in the middle. It provides the tightness between the body and the gate and avoids any kind of leakage to the atmosphere.

The packing is located in an easily accessible place and can be changed without dismantling the valve from the pipeline.

Several types of packing can be supplied according to the different applications in which the valve can be located as follows:

#### **GREASED COTTON (Recommended for hydraulic services)**

This packing is made with cotton threads and has impregnated both the inside and the outside with tallow. It is manufactured by the solid system. It is a packing for general use in hydraulic services for pumps as well as for valves.

P(bar) = 10 / T = 100°C PH = 6-8

#### **COTTON + P.T.F.E.**

This packing is made with cotton threads and has the inside and outside impregnated with P.T.F.E. It is manufactured by the solid system. It is a packing for general use in hydraulic services for pumps as well as for valves.

P(bar) = 30 / T = 120°C PH = 6-8

#### **P.T.F.E. LUBRICATED**

It is made of PTFE filament threads which are impregnated using vacuum with a dispersion of PTFE and a special lubricant which helps the work at high speed.

It is braided by the diagonal system. Suitable for valves and pumps working with nearly all the fluids, specially the more corrosives, including concentrated oils and oxidants. It is also suitable for fluids with solid contents.

P(bar) = 100/ T = -200+270 °C PH = 0-14



### **5) SPINDLE (STEM)**

The spindle (stem) of the CMO valve is made of stainless steel 18/8. This provides a high resistance and long corrosion resistant life.

The valve design can be with rising or non rising stem construction. When rising stem construction is manufactured a stem protection hood is supplied that protects the stem from dust and dirty and, at the same time, keeps the stem lubricated.

### **6) PACKING GLANDS**

The packing glands give the possibility to apply a uniform pressing force on the packing to ensure the tightness of the packing. As standard cast iron body valves include aluminium packing glands and stainless steel body valves include CF8M stainless steel packing glands.

### **7) ACTUATORS**

Even if the valve is normally operated by a pneumatic actuator other kind of actuators can be supplied with the advantage that CMO design is completely interchangeable.

The design gives the possibility to the customer to change the actuators by their own. Normally there is no need of any extra mounting kit and in the cases that it is necessary CMO provides it.

## **ACCESSORIES**

Several types of accessories are available to adapt the valve to specific working conditions, such as:

#### **Stellited gate**

Addition of stellite material on the gate wedge to protect it from abrasion.

#### **Scraper in the packing**

It cleans the gate during the opening movement to avoid the damage of the packing.

#### **Flushing holes in body**

Several holes can be drilled on the body to flush air, steam or other fluid for cleaning of the valve seat.

#### **Mechanical Limit Switches, Inductive Switches and Positioners**

Limit switches for punctual valve position indication and positioners for continuous valve position indication.

#### **Solenoid valves**

For air distribution into pneumatic actuators

#### **Connection electrical boxes, electrical wiring and pneumatic piping**

Completely assembled units with all accessories can be supplied.

#### **Stroke limiting mechanical stops**

#### **Mechanical locking device**

Allows the locking of the valve in a fixed position during long periods

#### **Emergency manual actuator (hand wheel /gear box)**

For emergency operation of the valve in case of power failure

# KNIFE GATE VALVES – MODEL E

DOC. E.07/08

## ACTUATORS

The following actuators are available:

### MANUAL ACTUATORS

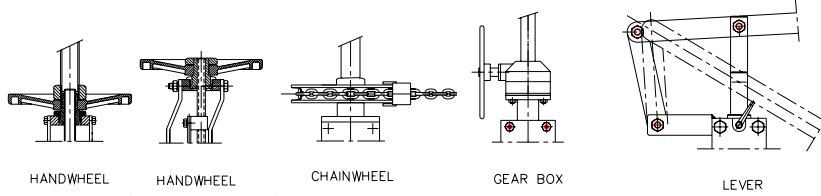

HANDWHEEL

HANDWHEEL  
(NON RISING SPINDLE)

CHAINWHEEL

GEAR BOX

LEVER

(\*NOTE: CHAINWHEEL AND GEAR BOX ALSO AVAILABLE  
NON RISING STEM DESIGN

### OTHER TYPES OF ACTUATORS

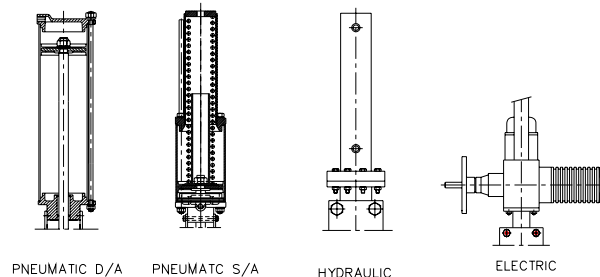

PNEUMATIC D/A

PNEUMATIC S/A

HYDRAULIC

ELECTRIC

(\*NOTE: SINGLE ACTING ACTUATOR AVAILABLE WITH  
WITH SPRING TO CLOSE OR SPRING TO OPEN  
DESIGN.

(\*NOTE: ALL AUTOMATED VALVES ARE SUPPLIED WITH  
SAFETY GUARDS COVERING THE GATE MOVEMENT AREA.

## GENERAL DIMENSIONS: HANDWHEEL – RISING STEM (non rising stem also available)

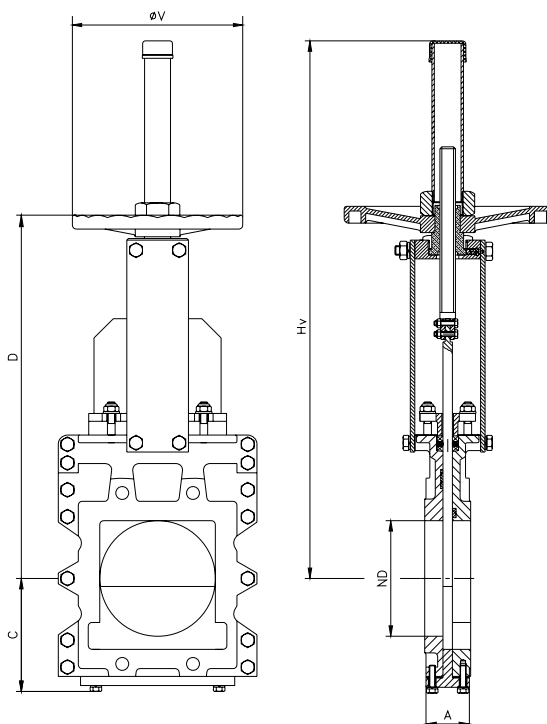

ND	DIMENSIONS				
	A	C	øV	D	Hv
50	40	86	225	310	440
65	40	95	225	335	470
80	50	114	225	365	490
100	50	135	225	395	520
125	50	145	225	430	615
150	60	155	225	480	675
200	60	185	325	600	840
250	70	235	325	690	1045
300	70	265	380	790	1160
350	96	290	460	910	1370
400	100	325	460	975	1465
450	106	350	460	1100	1640
500	110	380	460	1250	1770
600	110	470	460	1405	1965

# KNIFE GATE VALVES – MODEL E

DOC. E.07/08

## GENERAL DIMENSIONS: PNEUMATIC DOUBLE ACTING (air supply pressure: 6 kg/cm<sup>2</sup>)

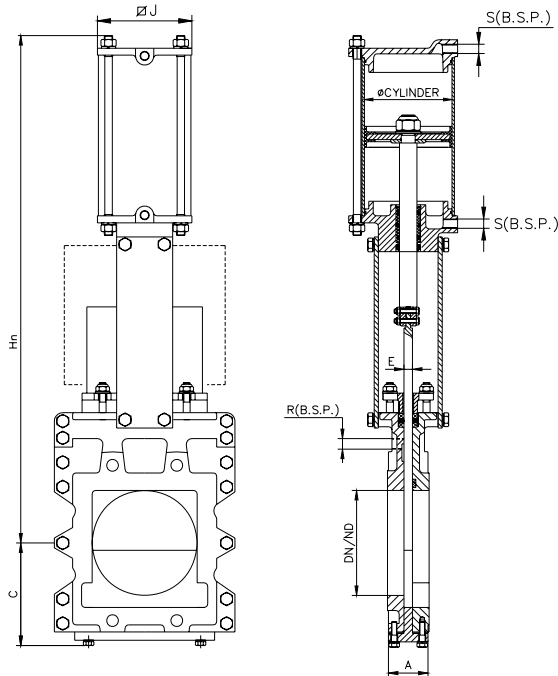

DN ND	DIMENSIONS							
	A	C	Ø CYLINDER	S B.S.P.	Ø J	Hn	R B.S.P.	E
50	40	86	80	1/4"	96	425	—	6
65	40	95	80	1/4"	96	470	—	6
80	50	114	100	1/4"	115	510	—	8
100	50	135	100	1/4"	115	557	—	8
125	50	145	125	1/4"	138	665	1/2"	10
150	60	155	160	1/4"	175	814	1/2"	12
200	60	185	200	1/4"	218	940	1/2"	15
250	70	235	250	3/8"	270	1070	1/2"	15
300	70	265	300	3/8"	382	1230	1/2"	15
350	96	290	300	1/2"	382	1440	1/2"	20
400	100	325	350	1/2"	426	1515	1/2"	20
450	106	350	350	1/2"	426	1780	1/2"	20
500	110	380	400	1/2"	538	1900	1/2"	25
600	110	470	400	1/2"	538	2120	1/2"	25

As standard the CMO double acting and single acting actuators are designed to work between 6 and 10 Kg/cm<sup>2</sup> air supply pressure (10 Kg/cm<sup>2</sup> is the maximum allowed air supply pressure). When the air supply pressure is less than 6 Kg/cm<sup>2</sup> the actuator is oversized.

### Double acting actuator:

For valves of diameter DN50 up to DN200 the cylinder jacket and the caps are in aluminium, the piston rod in AISI304, the cylinder piston in steel covered by nitrile and the o-rings in nitrile. For valves bigger than DN200 the caps are manufactured in nodular cast iron or carbon steel.

The actuator can be manufactured fully in stainless steel under request and specially for very corrosive ambient.

### Single acting actuator:

Fail close or fail open single actuators are available (spring to close or spring to open).

For all size of valves the cylinder jacket is manufactured in aluminium, the caps are in cast iron or carbon steel, the piston rod in AISI304, the cylinder piston in steel covered by nitrile, the o-rings in nitrile and the spring in steel.

The single acting actuator with spring design is manufactured for valves up to DN300. For bigger sizes a double acting actuator is supplied including an air tank. This is tank keeps inside the necessary air volume to make the last stroke of movement in case of fail.

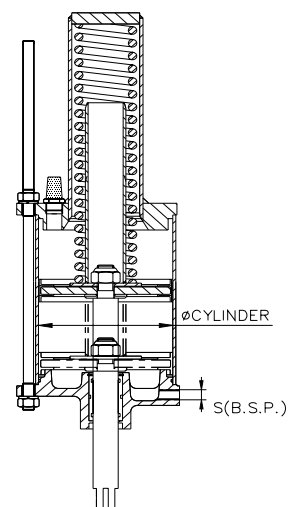

**Note:** Please read the "CMO pneumatic actuators" catalogue for more information.

# KNIFE GATE VALVES – MODEL E

DOC. E.07/08



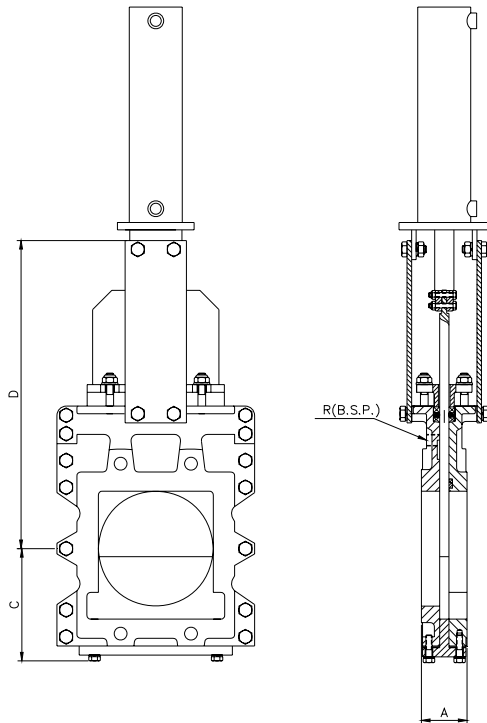

## GENERAL DIMENSIONS: HYDRAULIC ACTUATOR (135 kg/cm<sup>2</sup>)

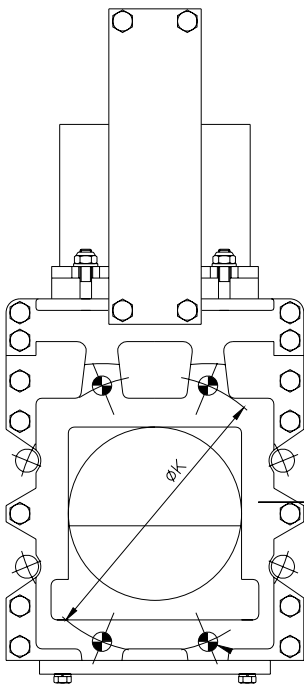

DN	DIMENSIONS			
	A	C	D	R B.S.P.
80	50	114	292	—
100	50	135	334	—
125	50	145	392	1/2"
150	60	155	425	1/2"
200	60	185	525	1/2"
250	70	235	620	1/2"
300	70	265	715	1/2"
350	96	290	781	1/2"
400	100	325	861	1/2"
450	106	350	985	1/2"
500	110	380	1064	1/2"
600	110	470	1224	1/2"

## FLANGE CONNECTION DETAILS



DN ND	DIN PN10					ANSI150				
			M Metric	P	ØK *			R UNC	P	ØK *
50	4	—	M.16	9	125	4	—	5/8"	9	120'6
65	4	—	M.16	9	145	4	—	5/8"	9	139'7
80	4	4	M.16	10	160	4	—	5/8"	10	152'4
100	4	4	M.16	10	180	4	4	5/8"	10	190'5
125	4	4	M.16	10	210	4	4	3/4"	10	215'9
150	4	4	M.20	11	240	4	4	3/4"	11	241'3
200	4	4	M.20	11	295	4	4	3/4"	11	298'4
250	8	4	M.20	13	350	8	4	7/8"	13	361'9
300	8	4	M.20	13	400	8	4	7/8"	13	431'8
350	12	4	M.20	22	460	8	4	1"	22	476'2
400	12	4	M.24	22	515	12	4	1"	22	539'7
450	16	4	M.24	24	565	12	4	1 1/8"	24	577'8
500	16	4	M.24	24	620	16	4	1 1/8"	24	635
600	16	4	M.27	24	725	16	4	1 1/4"	24	749'3