

KNIFE GATE VALVES -- MODEL D

DOC.T.07/08

PRODUCT DESCRIPTION

Flanged unidirectional knife gate valve for high pressure applications
One piece integral cast body with seating wedges and bolted bonnet.
High flow rates with low pressure drops.
Several seat and packing materials available.
Face to face dimension according to CMO standard.
Arrow in the body pointing the flow direction

GENERAL APPLICATIONS

This knife gate valve is appropriate for clean liquids or liquids containing solid particles.

Designed for a wide range of applications such us:

- Pulp and Paper.
- Mining.
- Effluent handling plants.
- Chemical plants.
- Food and beverage.
- Bulk conveying.
- Sewage applications.
- Pumping installations

TECHNICAL DATA

Standard manufacturing sizes:

From DN50 up to DN2000 (bigger sizes under request)

Working pressures:

From PN2.5 up to PN100

Each valve is designed according to the working conditions:

For PN16 – Maximum valve size DN1000

For PN-25 – Maximum valve size DN800

For PN-40 – Maximum valve size DN800

For PN-64 – Maximum valve size DN600

For PN-100 – Maximum valve size DN600



Note: These pressures are to be applied on the valve following the direction of the arrow stamped on the body side. Due to the valve design with seating wedges it is allowed 50% of these pressures in the opposite direction of the arrow. Bidirectional design also available under request

Flange connection drillings:

The standard flange connection is according to DIN PN10 and Ansi B16.5 (Class 150)

Other flange connections such as DIN PN6 – PN16 – PN25, British Standard, Australian Standard, JIS Standard, are available under request.

Applied Directives:

Directive 98/37/CE (machinery), **Directive 97/23/CE (PED: Group 2)**, Directive 94/9/CE (ATEX: Group II, Cat. 3 / Zones 2 and 22)

Quality Dossier: All valves are hydrostatically tested at CMO with water and CMO material and test certificates can be provided.

Body test pressure = Maximum rated pressure x 1,5

Seat test pressure = Maximum rated pressure x 1,1

KNIFE GATE VALVES -- MODEL D

DOC.T.07/08

ADVANTAGES OF CMO "MODEL D" COMPARING WITH SIMILAR PRODUCTS

The model D has conically shaped inside body walls that provide a bigger space and the face to face is longer than on standard knife gate valves. This allows to the solids to move free inside of the body and when closing the knife the product stocked in the inside of the body is cleared easily. That is why it is also known as self cleaning bonnet valve.

This valve is defined as unidirectional and on unidirectional knife gate valves when there is a back pressure the knife can bend. This is something that can not happen with the CMO type D valve because it has a guiding supports system that allows to the valve to work with a back pressure of 50% of the maximum rated working pressure without any deformation of the knife.

The stem protection hood is independent from the hand wheel fixing system, so the hood can be removed without removing the hand wheel. This point allows normal maintenance operations like greasing of the spindle, etc.

The spindle (stem) of the CMO valve is made of stainless steel 18/8. This point is very important because there are manufacturers that manufacture it with 13% CR and it gets rusty in a very short time.

The hand wheel of the manual actuator is made of nodular iron GGG-50. Some manufacturers manufacture it on normal cast iron and they can break easily when receiving any big torque or knock.

The bridge of the CMO manual actuator is manufactured in a compact way, with the bronze nut protected in a greased and closed box. This point gives the possibility to move it with a key even without the hand wheel (in other manufacturer valves this is not possible).

The pneumatic actuator upper and lower caps are made of nodular iron GGG-50, therefore their resistance to the knocks is very high. This characteristic is essential in this type of pneumatic cylinder. Special care must be taken with cylinders with covers in aluminium or cast iron

The sealing o-rings of the pneumatic cylinders are commercial and they can be bought all over the world, it is not needed, therefore, to contact CMO every time that these spares are needed.

STANDARD MANUFACTURING MATERIALS (OPTIONS 1 AND 2)

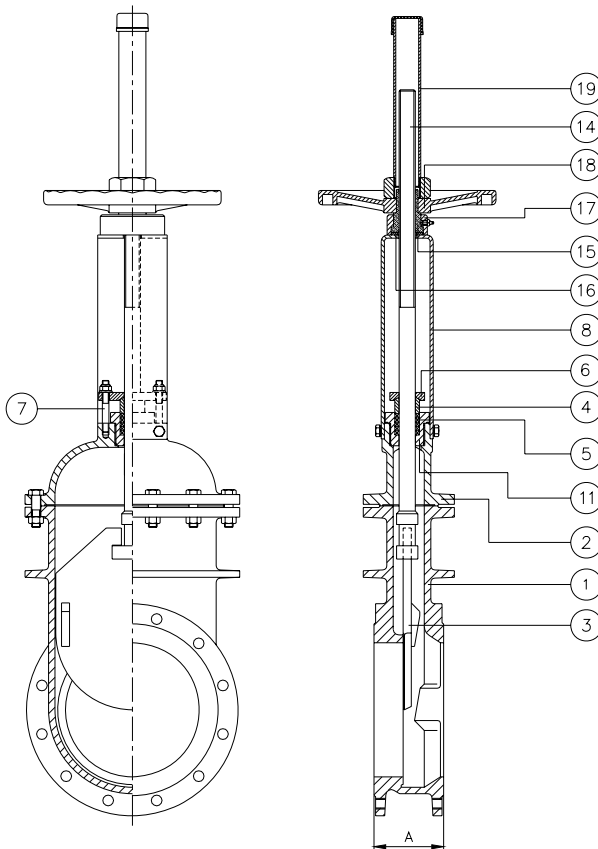

POS.	DESCRIPCION	OPTION 1	OPTION 2
1	BODY	A 216 WCB	CF8M
2	BONNET	A 216 WCB	CF8M
3	GATE	304	316
4	PACKING GLAND	304	316
5	PACKING	SYNTHETIC+PTFE	SYNTHETIC+PTFE
6	PACKING GLAND FLANGE	CARBON STEEL	316
7	STUDS	ZINC PLATED STEEL	316
8	SUPPORTS	CARBON STEEL	CARBON STEEL
9	SEALING RING	304	316
10	SEALING JOINT	EPDM	EPDM
11	PACKING CASE	420	316
12	DEFLECTOR	CA15	CA15/CF8M
13	JOINT	BELPA DW	BELPA DW
14	STEM	303	316
15	ACTUATOR NUT	BRONZE	BRONZE
16	NUT	304	304
17	BRIDGE	CARBON STEEL	CARBON STEEL
18	HANDWHEEL	NODULAR CAST IRON	NODULAR CAST IRON
19	PROTECITON HOOD	CARBON STEEL	CARBON STEEL

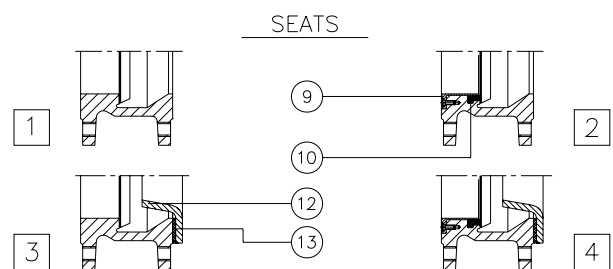

DESIGN FEATURES IN DETAIL

1) BODY

Flanged style, one piece mono block cast body with seating wedges for tighter shut-off and bolted bonnet. For sizes bigger than DN1200 the construction of the body is fabricated in carbon steel with reinforcement ribs to withstand the maximum rated pressure.

Full port designed to provide high flow rates with low pressure drops.

The internal design of the valve avoids any build up of solids on the sealing area and the extra long face to face dimension allows to the solids to move free inside of the casing.

The standard manufacturing materials are A216WCB carbon steel and CF8M stainless steel. Other materials like GGG50 nodular cast iron and stainless steel alloys (AISI316Ti, Duplex, 254SMO, Uranus B6 ...) under request.

Cast iron or carbon steel valves are painted as standard with 80 microns anticorrosive protection of EPOXY (colour RAL 5015). Other anticorrosive protections available under request

2) GATE

The standard manufacturing materials are AISI304 stainless steel for carbon steel body valve and AISI316 stainless steel for CF8M stainless steel body valve. Other materials or combinations can be supplied under request.

The gate is polished in both sides to provide a smooth contact surface with the sealing joint. At the same time the gate wedge is rounded to avoid cutting of the sealing. Several polishing grades, anti abrasion treatments and modifications are available to adapt the valve to the customer requirements.

3) SEAT

Four different seat constructions are available according to the application in which the knife gate valve will work as follows:

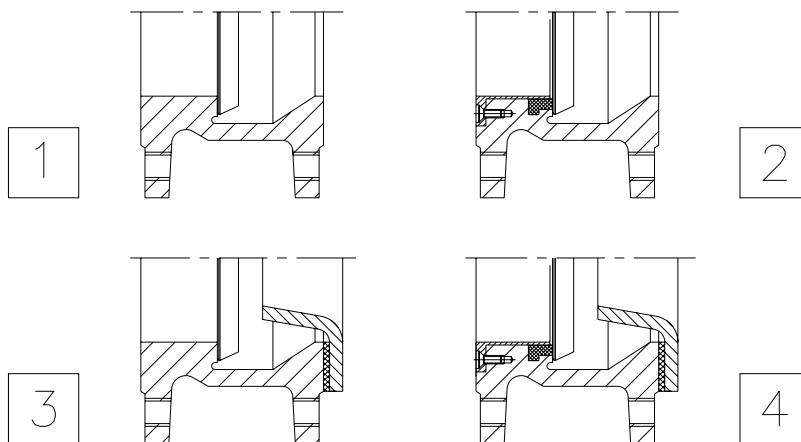

Seat number 1: Metal to metal seat. This seat construction does not include any resilient sealing and the estimated leakage (considering water) is 1.5% of the flow.

Seat number 2: Standard soft seated valve. This seat construction includes a resilient joint that is held on the valve body by an AISI316 stainless steel retaining ring. This retaining ring goes bolted to the valve body to avoid its loosening because of the pressure.

Seats number 3 and 4: Equal to seats 1 and 2 but including a deflector. The deflector is a conical shaped ring located on the valve inlet with two functions (protect the valve body from abrasion guide the flow to the centre of the valve).

 **Note:** Three materials are available for reinforced socket and deflector (CA-15 steel, CF8M and Ni-hard).



Resilient Seat Materials

EPDM

This is the standard resilient seat installed on CMO valves. It can be used in many applications, but generally it is used for water and products diluted in water at temperatures not higher than 90°C. The EPDM rubber can also be used for abrasive products. It provides 100% tightness.

NITRILE

It is used for greasy fluids or oils at temperatures not higher than 90 °C. It provides 100% tightness.

VITON

Appropriate for corrosive products and high temperatures up to 190°C in continuous and picks of 210°C. It provides 100% tightness.

SYLICONE

The silicone is used mainly into the food industry and pharmaceutical products with temperatures not higher than 200°C. It provides 100% tightness.

 **Note:** In some applications other different resilient materials are used as, for example, hypalon, butile and natural rubber. Please contact with us in case of such request.

PTFE

It is used for corrosive products and PH from 2 to 12. This sealing material does not proved 100% tightness. The estimated leakage is 0.5% of the total flow.

4) PACKING

As standard the packing is composed by three lines with an EPDM o-ring in the middle. It provides the tightness between the body and the gate and avoids any kind of leakage to the atmosphere.

The packing is located in an easily accessible place and can be changed without dismantling the valve from the pipeline.

Several types of packing can be supplied according to the different applications in which the valve can be located as follows:

GREASED COTTON (Recommended for hydraulic services)

This packing is made with cotton threads and has impregnated both the inside and the outside with tallow. It is manufactured by the solid system. It is a packing for general use in hydraulic services for pumps as well as for valves.

P(bar) = 10 / T = 100°C PH = 6-8

DRY COTTON

This packing is made with cotton threads. It is manufactured by the solid system. This is a packing only for solid products.

P(bar) = 0.5 / T = 100°C PH = 6-8

COTTON + P.T.F.E.

This packing is made with cotton threads and has the inside and outside impregnated with P.T.F.E. It is manufactured by the solid system. It is a packing for general use in hydraulic services for pumps as well as for valves.

P(bar) = 30 / T = 120°C PH = 6-8



P.T.F.E. LUBRICATED

It is made of PTFE filament threads which are impregnated using vacuum with a dispersion of PTFE and a special lubricant which helps the work at high speed.

It is braided by the diagonal system. Suitable for valves and pumps working with nearly all the fluids, specially the more corrosives, including concentrated oils and oxidants. It is also suitable for fluids with solid contents.

$$P(\text{bar}) = 100 / T = -200+270 \text{ } ^\circ\text{C} \quad \text{PH} = 0-14$$

GRAPHITE FILAMENT

It is made of graphite threads of high purity. It is braided by the diagonal system and impregnated with a small quantity of graphite and lubricant which helps to reduce the porosity and makes easier the running.

It is a packing with low friction coefficient and high heat conductivity.

It has a wide range of applications, as the graphite withstands the steam, water, oils, solvents, alkalis and most of the acids.

The chemical products that attack this packing are strong oxidizers as the oleum, the fuming nitric acids, the dichromates and the oxygen.

$$P(\text{bar}) = 40 / T = 650^\circ\text{C} \quad \text{PH} = 0-14$$

CERAMIC FIBER

It is made with ceramic threads. Its application is only for air or gas at high temperature and low pressure.

$$P(\text{bar}) = 0.3 / T = 1400^\circ\text{C} \quad \text{PH} = 0-14$$

5) SPINDLE (STEM)

The spindle (stem) of the CMO valve is made of stainless steel 18/8. This provides a high resistance and long corrosion resistant life.

The valve design can be with rising or non rising stem construction. When rising stem construction is manufactured a stem protection hood is supplied that protects the stem from dust and dirt and, at the same time, keeps the stem lubricated.

6) PACKING GLAND

The packing gland gives the possibility to apply a uniform pressing force on the packing to ensure the tightness of the packing. As standard carbon steel body valves include steel packing gland and stainless steel body valves include CF8M stainless steel packing gland.

7) ACTUATORS

All kind of actuators can be supplied with the advantage that CMO design is completely interchangeable.

The design gives the possibility to the customer to change the actuators by their own. Normally there is no need of any extra mounting kit and in the cases that it is necessary CMO provides it.



ACCESSORIES

Several types of accessories are available to adapt the valve to specific working conditions, such as:

Mirror Polished Gate

The mirror polished gate is specially recommended for food industry and applications where the solids can stick on the gate. The mirror polished gate is an alternative to solve such kind issues.

PTFE Lined Gate

As the mirror polished gate, it improves the performance of the valve against the adherence.

Stellited gate

Addition of stellite material on the gate wedge to protect it from abrasion.

Scraper in the packing

It cleans the gate during the opening movement to avoid the damage of the packing.

Air injection in the packing gland

Injecting air inside of the packing (stuffing box) an air chamber is created that improves the tightness of it.

Heating jacket

Recommended in applications in which the working fluid can get hard inside of the body casing. The heating jacket keeps the body temperature constant avoiding solidification of the working media.

Flushing holes in body

Several holes can be drilled on the body to flush air, steam or other fluid for cleaning of the valve seat.

Mechanical Limit Switches, Inductive Switches and Positioners

Limit switches for punctual valve position indication and positioners for continuous valve position indication.

Solenoid valves

For air distribution into pneumatic actuators

Connection electrical boxes, electrical wiring and pneumatic piping

Completely assembled units with all accessories can be supplied.

Stroke limiting mechanical stops

Mechanical locking device

Allows the locking of the valve in a fixed position during long periods

Emergency manual actuator (hand wheel /gear box) (Figure 2)

For emergency operation of the valve in case of power failure

Triangular (V-notch) and pentagonal diaphragm with indication rule

Recommended for flow regulation purposes

According to the opening percentage of the valve gives the flow passing through the valve.

ACTUATORS

The following actuators are available:

MANUAL ACTUATORS

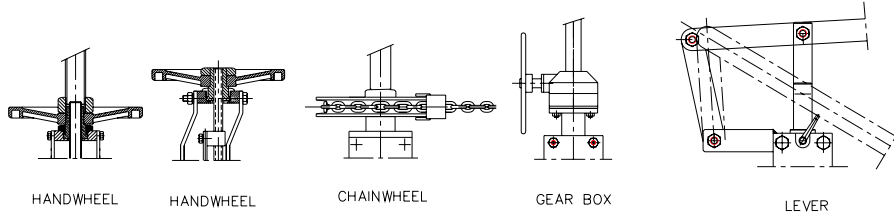

HANDWHEEL

HANDWHEEL
(NON RISING SPINDLE)

CHAINWHEEL

GEAR BOX

LEVER

(*)NOTE: CHAINWHEEL AND GEAR BOX ALSO AVAILABLE
NON RISING STEM DESIGN

OTHER TYPES OF ACTUATORS

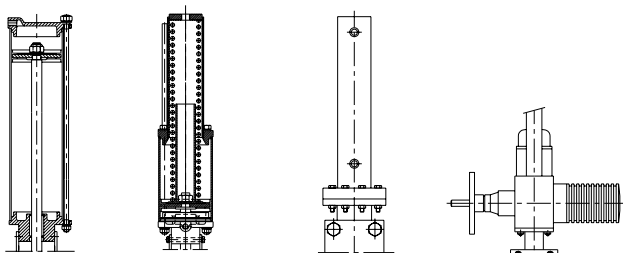

PNEUMATIC D/A

PNEUMATIC S/A

HYDRAULIC

ELECTRIC

(*)NOTE: SINGLE ACTING ACTUATOR AVAILABLE WITH
WITH SPRING TO CLOSE OR SPRING TO OPEN
DESIGN.

(*)NOTE: ALL AUTOMATED VALVES ARE SUPPLIED WITH
SAFETY GUARDS COVERING THE GATE MOVEMENT AREA.

KNIFE GATE VALVES -- MODEL D

DOC.T.07/08

STEM EXTENSION TYPES

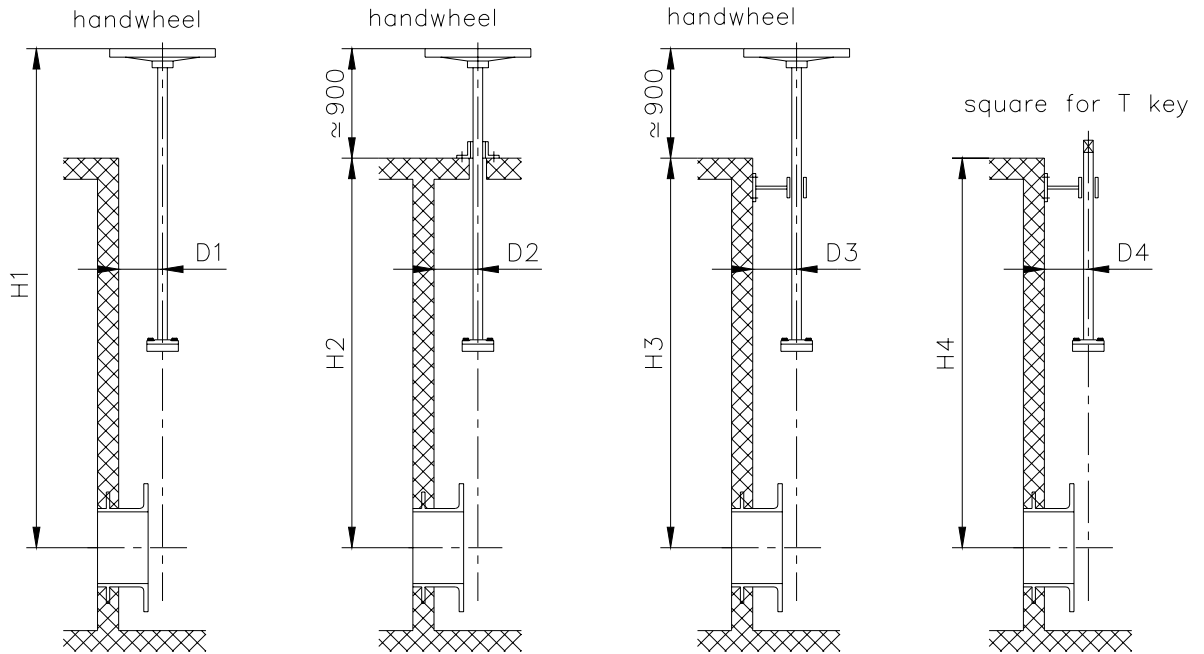

- 1) Extension tube with inside rising stem
- 2) Equal to 1) but with floor support
- 3) Equal to 1) but with wall support
- 4) Equal to 3) but with T key.

* Optional indication rule on the pedestal

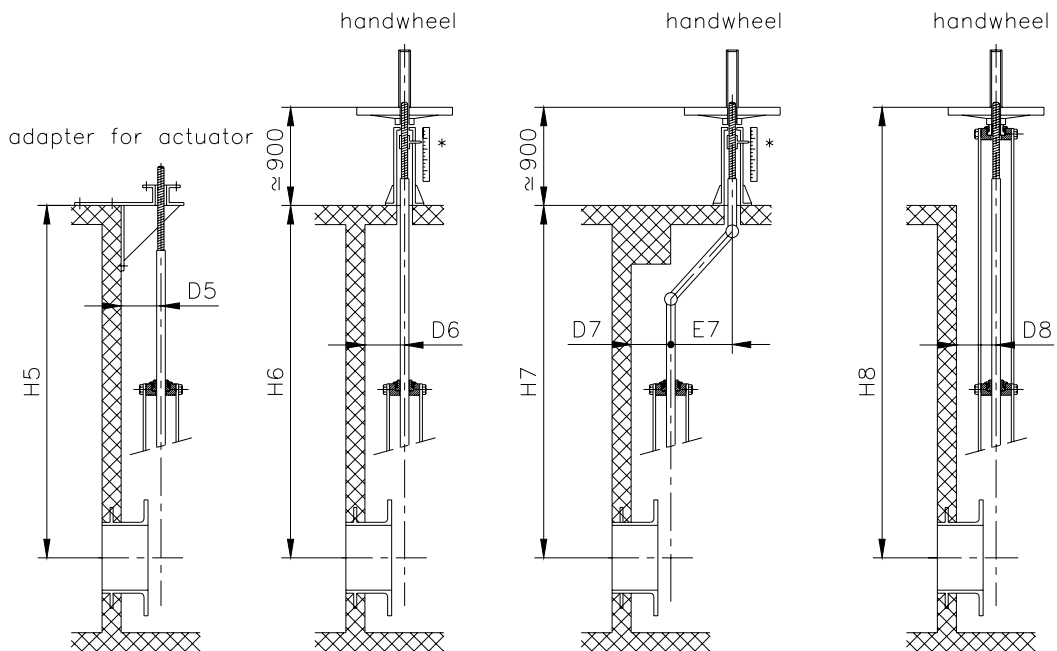

- 5) Rising stem with wall support and adapter for actuator
- 6) Rising stem with floor pedestal
- 7) Non rising stem with pedestal and two universal joints
- 8) Rising stem with extended support plates

KNIFE GATE VALVES -- MODEL D

DOC.T.07/08

GENERAL DIMENSIONS: HANDWHEEL – RISING STEM

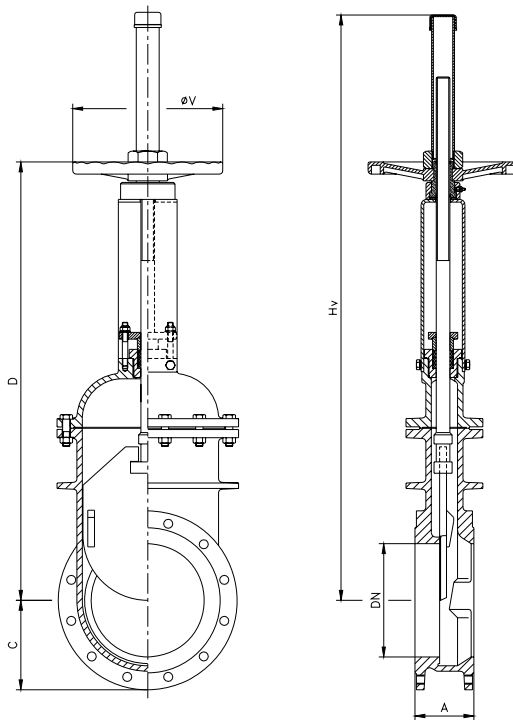

DN	DIMENSIONS				
	A	C	D	øV	Hv
50	60	52	375	225	470
65	60	62	410	225	525
80	70	70	445	225	575
100	70	80	485	225	680
125	90	127	540	225	730
150	90	145	585	225	770
200	100	175	690	325	940
250	114	205	950	380	1255
300	120	245	1090	460	1460
350	127	270	1250	460	1640
400	140	300	1410	460	1805
450	152	320	1540	460	2005
500	162	360	1605	460	2250
600	178	420	1950	460	2600

GENERAL DIMENSIONS: HANDWHEEL – NON RISING STEM

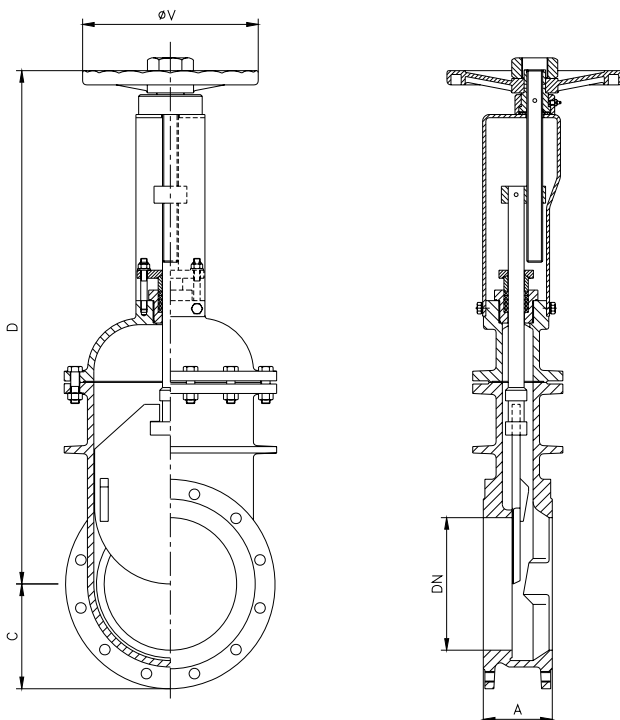

DN	DIMENSIONS			
	A	C	D	øV
150	76	145	690	225
200	89	175	690	325
250	114	205	950	380
300	120	245	1090	460
350	127	270	1250	460
400	140	300	1410	460
450	152	320	1540	460
500	162	360	1605	460
600	178	420	1950	460

KNIFE GATE VALVES -- MODEL D

DOC.T.07/08

GENERAL DIMENSIONS: PNEUMATIC DOUBLE ACTING (air supply pressure: 6 kg/cm²)

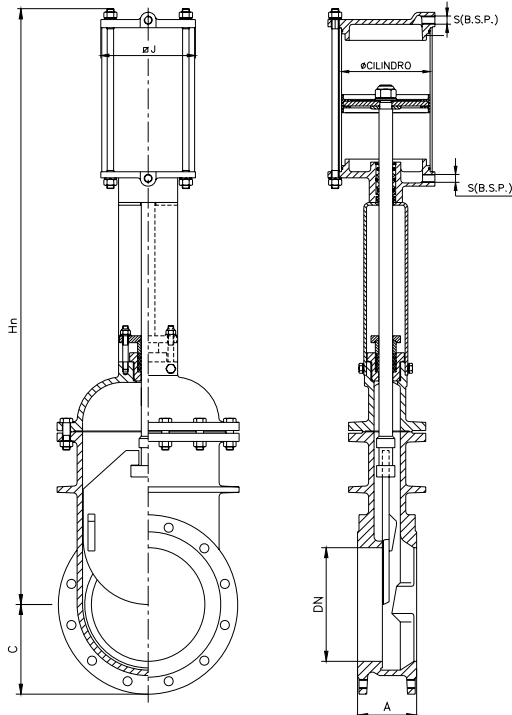

DN	DIMENSIONS					
	A	C	Ø CYLINDER	S B.S.P.	Ø J	Hn
150	90	145	125	1/4"	138	850
200	100	175	160	3/8"	175	1025
250	114	205	200	3/8"	218	1330
300	120	245	250	3/8"	270	1570
350	127	270	250	3/8"	270	1720
400	140	300	300	1/2"	382	1945
450	152	320	300	1/2"	382	2160
500	162	360	350	1/2"	426	2375
600	178	420	350	1/2"	426	2760

As standard the CMO double acting and single acting actuators are designed to work between 6 and 10 Kg/cm² air supply pressure.

10 Kg/cm² is the maximum allowed air supply pressure. When the air supply pressure is less than 6 Kg/cm² the actuator is oversized.

Double acting actuator:

For valves of diameter DN50 up to DN200 the cylinder jacket and the caps are in aluminium, the piston rod in AISI304, the cylinder piston in steel covered by nitrile and the o-rings in nitrile.

For valves bigger than DN200 the caps are manufactured in nodular cast iron or carbon steel.

The actuator can be manufactured fully in stainless steel under request and specially for very corrosive ambient.

Single acting actuator:

Fail close or fail open single actuators are available (spring to close or spring to open).

For all size of valves the cylinder jacket is manufactured in aluminium, the caps are in cast iron or carbon steel, the piston rod in AISI304, the cylinder piston in steel covered by nitrile, the o-rings in nitrile and the spring in steel.

The single acting actuator with spring design is manufactured for valves up to DN300. For bigger sizes a double acting actuator is supplied including an air tank. This is tank keeps inside the necessary air volume to make the last stroke of movement in case of fail.

Note: Please read the "CMO pneumatic actuators" catalogue for more information.

KNIFE GATE VALVES -- MODEL D

DOC.T.07/08

GENERAL DIMENSIONS: ELECTRIC ACTUATOR – RISING STEM (bare shaft also available)

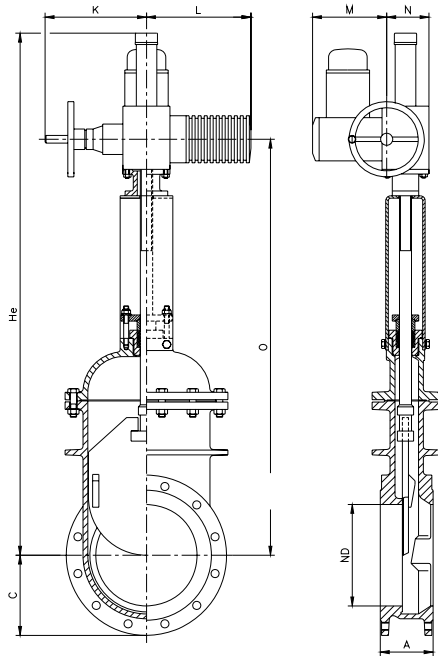

ND	DIMENSIONS							
	A	C	K	L	M	N	O	He
150	76	145	250	265	417	62	625	810
200	89	175	250	265	417	62	740	960
250	114	205	250	265	417	62	990	1325
300	120	245	256	282	427	65	1150	1490
350	127	270	256	282	427	65	1310	1785
400	140	300	325	385	465	90	1490	1880
450	152	320	325	385	465	90	1635	2045
500	162	360	325	385	465	90	1760	2360
600	178	420	332	385	465	90	2105	2680

GENERAL DIMENSIONS: HYDRAULIC ACTUATOR (oil supply pressure: 135 Kg/cm²)

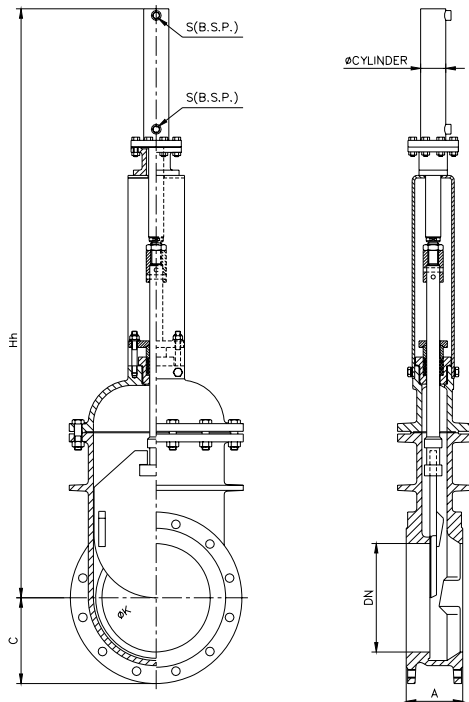

DN	DIMENSIONS				
	A	C	Ø CYLINDER	S B.S.P.	Hh
150	76	145	40	1/2"	930
200	89	175	40	1/2"	1110
250	114	205	63	3/4"	1415
300	120	245	63	3/4"	1680
350	127	270	80	3/4"	1855
400	140	300	80	3/4"	2080
450	152	320	100	1"	2585
500	162	360	100	1"	2745
600	178	420	100	1"	2920

KNIFE GATE VALVES -- MODEL D

DOC.T.07/08

FLANGE CONNECTION DETAILS

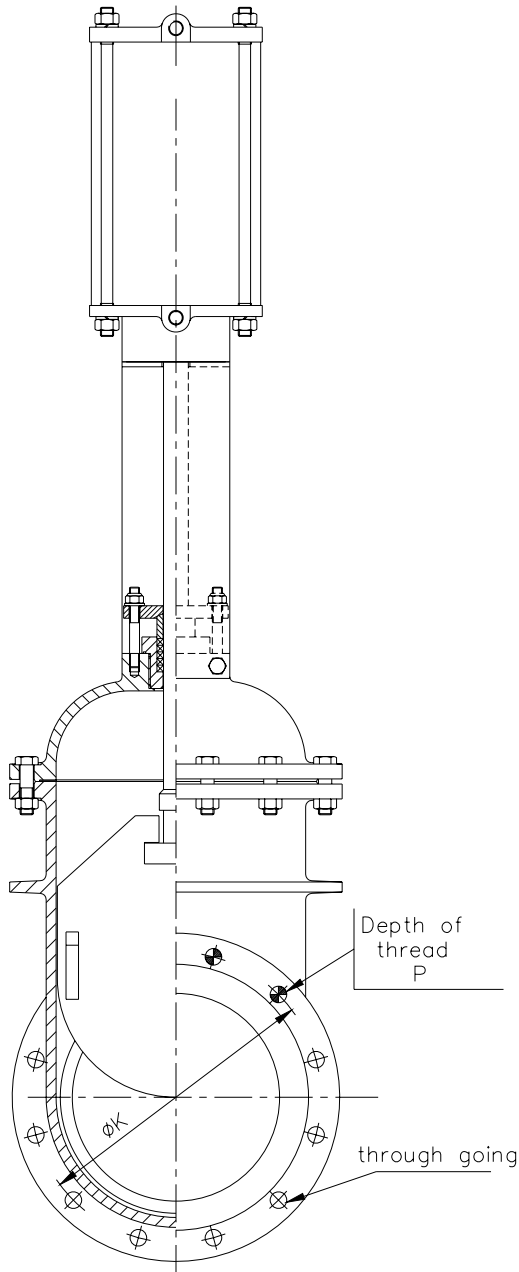

DN	DIN PN10					
	+	○	M Metric	∅ Through	P	∅K
150	4	4	M.20	22	12	240
200	4	4	M.20	22	14	295
250	4	8	M.20	22	18	350
300	4	8	M.20	22	18	400
350	6	10	M.20	22	20	460
400	6	10	M.24	26	22	515
450	8	12	M.24	26	22	565
500	8	12	M.24	26	24	620
600	8	12	M.27	30	25	725

DIN PN16						
+	○	M Metric	∅ Through	P	∅K	
4	4	M.20	22	12	240	
4	8	M.20	22	12	295	
4	8	M.24	26	14	355	
4	8	M.24	26	16	410	
6	10	M.24	26	16	470	
6	10	M.27	30	20	525	
8	12	M.27	30	20	585	
8	12	M.30	33	20	650	
8	12	M.33	36	24	770	

DIN PN25						
+	○	M Metric	∅ Through	P	∅K	
4	4	M.24	27	12	250	
4	8	M.24	27	12	310	
4	8	M.27	30	14	370	
6	10	M.27	30	16	430	
6	10	M.30	33	16	490	
6	10	M.33	36	20	550	
8	12	M.33	36	20	600	
8	12	M.33	36	20	660	
8	12	M.36	39	24	770	

ANSI150						
+	○	R UNC	∅ Through	P	∅K	
4	4	3/4"	23	12	241'3	
4	4	3/4"	23	14	298'4	
4	8	7/8"	25	18	361'9	
4	8	7/8"	25	18	431'8	
4	8	1"	30	20	476'2	
6	10	1"	30	22	539'7	
6	10	1 1/8"	33	22	577'8	
8	12	1 1/8"	33	24	635	
8	12	1 1/4"	36	25	749'3	