

# Operating Manual

## Linear Actuators

MC250/24 • MC250/230 • MC253/24 • MC253/230  
MC500/24 • MC500/230 • MC503/24 • MC503/230

## General information

Amendment	Version	Date	Modifications
	1.0	August 2004	Initial preparation
	2.0	July 2007	Complete revision and amendment
	2.1	March 2011	Revision

**Copyright** The copyright for this operating manual as well as all rights in case of patent awarding or registration of registered design remains with the manufacturer!

**Subject to alteration** The regulations, directives, standards etc. are compliant with the current state of information at the time of development and are not subject to modification service. They must be applied by the operator at his own responsibility in their latest valid version.

Concerning all data, information, and illustrations in this manual we reserve the right of technical modifications and improvements. No claims can be considered for alteration or rework of already delivered lift drives.

**Manufacturer** **HORA**  
 Geschäftsbereich Flow Control  
 Holter Regelarmaturen GmbH & Co. KG  
 Helleforthstrasse 58–60  
 33758 Schloss Holte-Stukenbrock  
 Germany

phone: +49 (0) 5207/8903-0

mail: [fc@hora.de](mailto:fc@hora.de)

[www.hora.de](http://www.hora.de)

# Content

<b>1 Safety</b> .....	<b>4</b>	<b>5 Commissioning</b> .....	<b>22</b>
1.1 Proper use .....	4	5.1 Operating parameters and coding switch positions .....	22
1.2 Information for the operator .....	4	5.2 Set input signal.....	23
1.3 Personnel.....	5	5.3 Set actuating time .....	23
1.4 Prior to starting work.....	5	5.4 Set hysteresis.....	24
1.5 During operation .....	5	5.5 Set actuating direction.....	24
1.6 Working environment.....	5	5.6 Set Autotest and Autopause .....	24
<b>2 Product Specification</b> .....	<b>6</b>	5.7 Set limit position .....	25
2.1 Components .....	6	5.8 Set potential-free way-switch .....	25
2.2 Accessories .....	7	5.9 Initialise the path-measuring system.....	27
2.3 Operating modes .....	7	5.10 Commissioning.....	28
2.3.1 Continuous mode .....	7	<b>6 Operation</b> .....	<b>29</b>
2.3.2 Three-point mode .....	8	6.1 Switching between Manual and Automatic modes .....	29
2.4 Functions .....	8	6.2 LED display .....	30
2.4.1 Binary signal / Frost protection function .....	8	<b>7 Maintenance, Care and Repairs</b> .....	<b>30</b>
2.4.2 Lock detection .....	8	<b>8 Spare parts</b> .....	<b>30</b>
2.4.3 Internal temperature monitoring .....	8	<b>9 Shutdown and Disposal</b> .....	<b>31</b>
2.4.4 Open-circuit detection.....	9	<b>10 Troubleshooting</b> .....	<b>31</b>
2.4.5 Set time .....	9	10.1 Troubleshooting .....	31
2.4.6 Hysteresis.....	9	10.2 Operating faults checklist.....	32
2.4.7 Manual mode and feedback signal.....	9		
2.4.8 Autotest .....	10		
2.4.9 Autopause .....	10		
2.4.10 Potential-free way-switch (optional extra).....	10		
2.5 Technical data .....	10		
2.6 Ratingplate.....	11		
<b>3 Transport and storage</b> .....	<b>11</b>		
<b>4 Assembly</b> .....	<b>12</b>		
4.1 Check the scope of supply.....	12		
4.2 Prepare for installation.....	12		
4.3 Mount linear actuator on valve.....	13		
4.4 Fit/remove cover .....	14		
4.5 Connect the electrics .....	15		
4.5.1 Control-independent switching .....	17		
4.5.2 Remove printed circuit board cover.....	18		
4.6 Optional extras installation.....	18		
4.6.1 Way-switch printed circuit board installation .....	19		
4.6.2 Fit the printed circuit board for mA output signal. ....	20		

# 1 Safety

Read these Operating Instructions carefully particularly the following safety instructions prior to installation and operation.



**DANGER**

## **DANGER**

Directly threatening hazard leading to death or serious physical injuries.



**WARNING**

## **WARNING**

Potentially hazardous situation which may lead to death or serious physical injuries.



**CAUTION**

## **CAUTION**

Potentially hazardous situation which could lead to minor physical injuries. Indicates a hazard which may cause material damage.



**ATTENTION**

## **ATTENTION**

Potentially hazardous situation where the product or an object in its environment may get damaged.

**Hint:** Utilisation instructions and other useful information.

## 1.1 Proper use

Linear actuators MC250/24, MC250/230, MC253/24, MC253/230, MC500/24, MC500/230, MC503/24, MC503/230 are controlled by three-point control or constant control. Linear actuators in the series described in these Operating Instructions are used for valve stroke adjustment.

Concurrence of the above type designation with the linear actuator rating plate must be checked prior to starting any operations in order to guarantee utilisation in accordance with specification. The data on the rating plate is decisive for linear actuator technical data and mains power supply requirements.

Any utilisation for tasks other than the aforementioned usage in accordance with specification and operating with mains power supply ratios other than those permitted is not deemed to be utilisation in accordance with specification. The operator bears sole liability for the risk to persons and machine and other assets in the event of utilisation not in accordance with specification.

The intended use also includes the compliance with accident preventions, DIN VDE regulations and safe working practices for all measures described in these operating instructions in due consideration of prevailing rules.

## 1.2 Information for the operator

Always keep the Operating Instructions available at the linear actuator deployment site.

Observe the current health and safety, accident prevention and DIN VDE standards for installation, operation and maintenance.

Take into consideration any additional regional, local or in-house safety regulations.

Ensure that every person entrusted with one of the tasks specified in these Operating Instructions has read and understood these instructions.

### 1.3 Personnel

Only qualified personnel may work on these linear actuators or in their vicinity. Qualified persons are those persons entrusted with installation, assembly, commissioning and operation or maintenance of the linear actuators and possessing the appropriate qualifications for their activity. The necessary and prescribed qualifications include:

- Training / instruction or authorization to turn on /off circuits and appliances / systems according to EN 60204 (DIN VDE 0100 / 0113) and the standards of safety technology.
- Training or instruction according to the standards of the safety technology concerning care and use of adequate safety and work protection equipment.
- First Aid training.

Work in a safe manner and refrain from any working practice which endangers the safety of persons or damages the linear actuator or other assets in any way whatsoever.

### 1.4 Prior to starting work

Prior to starting any work, check that the type designations specified here concur with the data on the linear actuator rating plate.

Linear actuators MC250/24, MC250/230, MC253/24, MC253/230, MC500/24, MC500/230, MC503/24, MC503/230.

### 1.5 During operation

Safe operation is only possible if transportation, storage, installation, operation and maintenance are carried out safely and materially and professionally correctly.

#### Transportation, installation and assembly

Observe the general set-up and safety regulations for heating, ventilation, air-conditioning and pipework design. Use tools correctly. Wear the necessary personal and other safety equipment.

#### Repairs and maintenance

Ensure that qualified personnel switch off the linear actuator prior to maintenance or repair work in accordance with DIN VDE.

### 1.6 Working environment

Read the data concerning the working environment in the Technical Data.

## 2 Product Specification

The linear actuator controls a step motor with the aid of a microcontroller. The rotational motion of the step motor is transformed into a linear motion via a planetary gearbox and a leadscrew with spindle nut.

### 2.1 Components

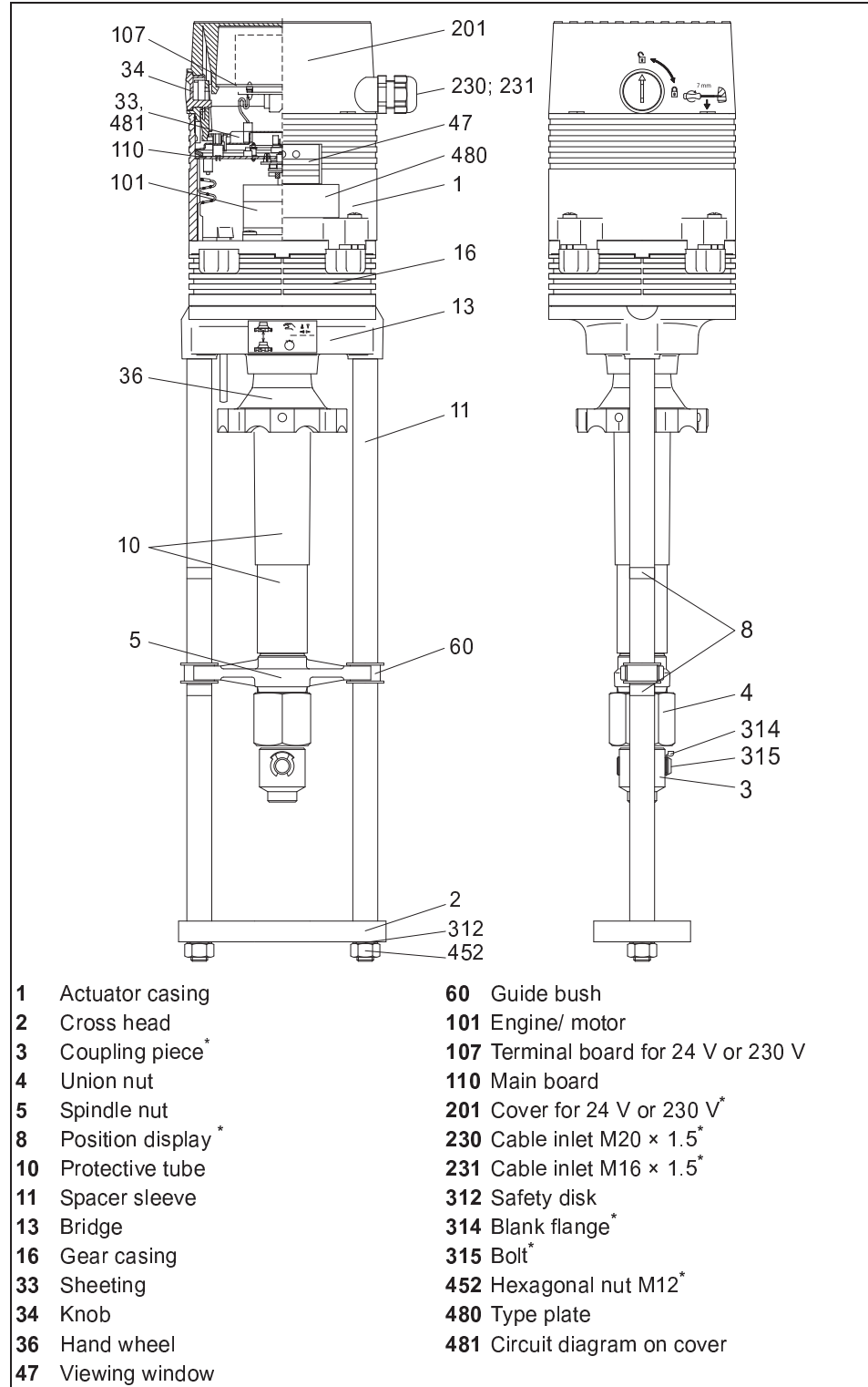

**Diagram 1** Component drawings

\* This component is available as a spare part!

## 2.2 Accessories

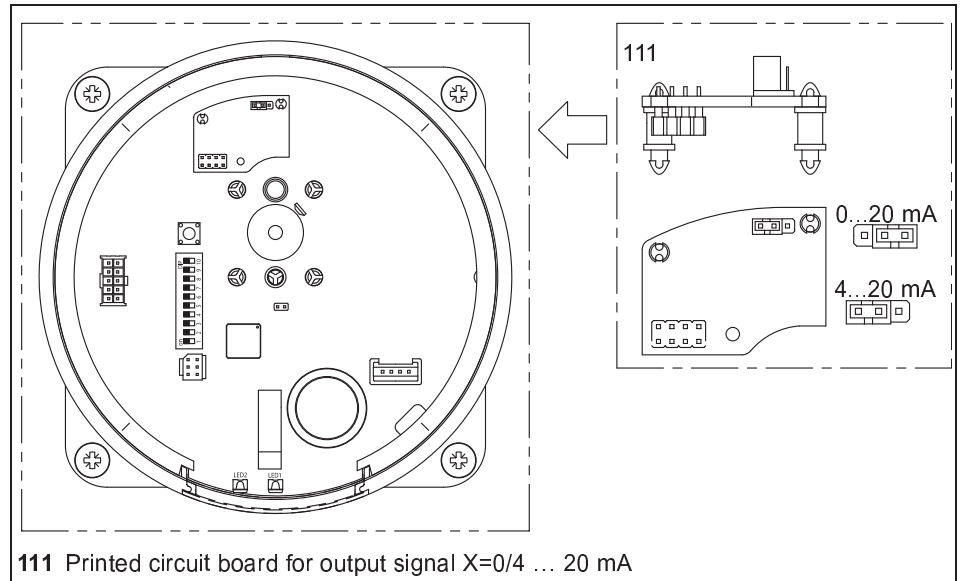

**Diagram 2** Printed circuit board for mA output signal on the motherboard

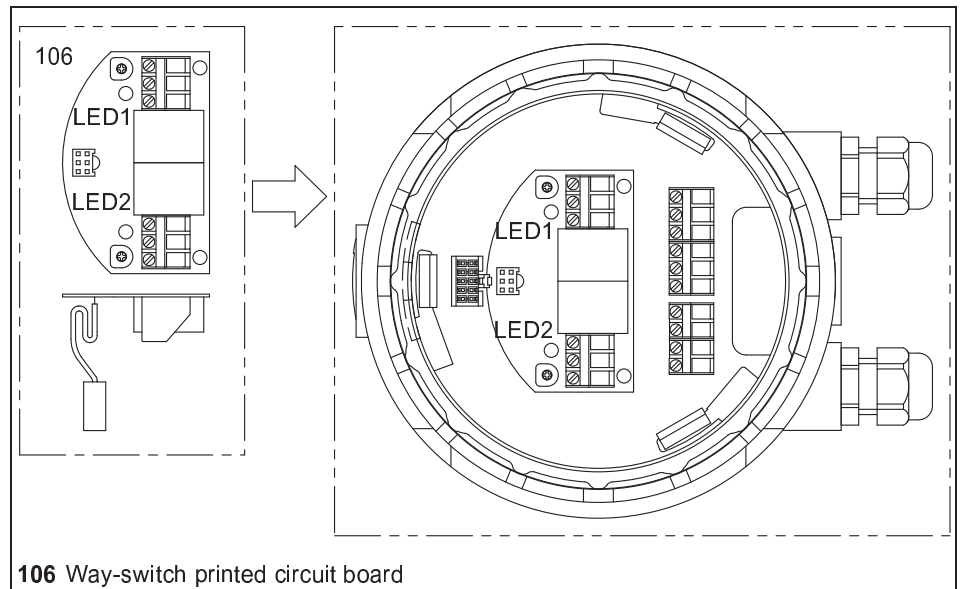

**Diagram 3** Way-switch printed circuit board in cover

## 2.3 Operating modes

The linear actuator can be operated in Manual or Automatic mode.

- The lift is adjusted via the handwheel in Manual mode.
- The lift is electrically controlled in Automatic mode.

### 2.3.1 Continuous mode

In Continuous mode the position of the linear actuator is specified by the system control. The input signal (Y) from the system control in the linear actuator is continually compared with the output signal (X) from the linear actuator for this purpose. The output signal is dependent on the position of the linear actuator (travel) in this instance.

The linear actuator moves until the input signal and the output signal correspond.

**Input signal (Y)** The input signal (Y) from the system control specifies the reference position for the linear actuator. It is an analogue signal on terminal Y.

The following input signals are possible:

- 0 ... 10 V DC / 2 ... 10 V DC
- 0 ... 20 mA / 4 ... 20 mA

**Output signal (X)** The output signal (X) specifies the actual position of the linear actuator. It is an analogue signal on terminal X.

0% to 100% valve lift is output as:

- 0 ... 10 V DC
- 0 ... 20 mA or 4 ... 20 mA (Printed circuit board for output signal as optional extra **(111)**)

### 2.3.2 Three-point mode

The direction of movement is specified via a control voltage on terminal 2 and terminal 3 on the motherboard:

- If the control voltage on terminal 2 is on, the spindle nut extends.
- If the control voltage on terminal 3 is on, the spindle nut retracts.

## 2.4 Functions

### 2.4.1 Binary signal / Frost protection function

Terminals B1 and B2 on the motherboard are bridged in Normal mode. If the circuit between B1 and B2 is broken, the linear actuator stores the actual position and then moves automatically to its limit position.

All other control signals are ignored during this process.

The linear actuator remains in the limit position until the circuit between B1 and B2 is closed again.

- In Three-point mode the linear actuator then returns automatically to the stored position.
- In Continuous mode the reference value of the input signal is again approached.

### 2.4.2 Lock detection

If the linear actuator becomes mechanically locked, it returns briefly and tries again to reach the required position. If this does not happen after a total of 7 attempts, the linear actuator is switched off to avoid damage to linear actuator and actuator.

The lock detection is displayed via the green LED in the **(47)** viewing window.

⇒ *Table 7* on page 30

### 2.4.3 Internal temperature monitoring

The actuator has internal temperature monitoring.

**Overheating protection** If the temperature in the actuator casing exceeds a limit value, the motor will be switched off. Once the motor has cooled down, it is automatically switched on again.

**Actuator heating** If the temperature in the actuator drops below 15 °C, the motor is switched to heating in the operating pauses. The actuator heating switches off automatically at a constant temperature of approx. 22 °C. The actuator heating does not affect the functions of the actuator.

Heating capacity:

- 12.5 W at temperatures from approx. 8 °C to approx. 15 °C
- 18 W at temperatures below 8 °C

The heating prevents the build-up of water condensation in the actuator and at the same time guarantees the smooth running of the gears even at temperatures up to approx. - 10°C.

Heating operation and motor switch-off are displayed via the LED in the **(47)** viewing window.

⇒ *Table 8 Red LED display* on page 30

#### 2.4.4 Open-circuit detection

Open-circuit detection is only available in Continuous mode with an input signal 2 ... 10 V DC and 4 ... 20 mA.

If the input signal drops below 1 V or 2 mA in Continuous mode, the linear actuator moves to the limit position set by coding switch S7.

Open-circuit detection is displayed via the green LED in the **(47)** viewing window.

⇒ *Table 7 Green LED display* on page 30

#### 2.4.5 Set time

The time the spindle nut takes to travel a defined path, is called actuating time. The actuating time is indicated in s/mm. The actuating time is set by coding switch S5.

⇒ *5.3 Set actuating time* on page 23

#### 2.4.6 Hysteresis

The differential of the input signal (Y) required after a reversal of the signal direction so that the spindle nut is moved, is called hysteresis.

It is used to avoid permanent oscillation of the actuator motor around a specific lift position in the event of slight input signal changes.

⇒ *5.4 Set hysteresis* on page 24

#### 2.4.7 Manual mode and feedback signal

The lift can be manually changed in Manual mode without power supply.

- The electronic motor and control are switched off in Manual mode so that lift movements by the control are not possible.
- As soon as the linear actuator is switched to Manual mode, the control switches a signal to Terminal R, if the power supply is on.

⇒ *6.1 Switching between Manual and Automatic modes* on page 29

### 2.4.8 Autotest

If a valve is not actuated over a long period, the valve cone may seize. The Autotest function prevents this. If the Autotest function of the linear actuator is switched on, the linear actuator moves after approx. 10 days without actuation automatically in rapid traverse to the limit position set by coding switch S7 and returns to the starting position.

⇒ 5.6 Set Autotest and Autopause on page 24

### 2.4.9 Autopause

The actuator uses this function to count the actuator commands which mean a change in direction. In the event of more than 20 different directional actuator commands per minute, a compulsory pause of 3 s is imposed.

⇒ 5.6 Set Autotest and Autopause on page 24

### 2.4.10 Potential-free way-switch (optional extra)

The optional way-switch printed circuit board **(106)** can be used to set two lift positions at which a potential-free electrical contact is opened or closed.

⇒ 5.8 Set potential-free way-switch on page 25

## 2.5 Technical data

Type	MC250/24, MC253/24, MC500/24, MC503/24	MC250/230, MC253/230, MC500/230, MC503/230
Supply voltage	24 V AC ± 10% 24 V DC ± 10%	115 V AC ± 10% 230 V AC + 6% -10%
Power consumption	max. 18 VA	max. 25 VA
Weight	MCxx0 = 7 kg MCxx3 = 7,4 kg	MCxx0 = 8,2 kg MCxx3 = 8,6 kg
Dimensions	See Technical Datasheets	
Stroke	max. 2.36 in	max. 2.36 in
Frequency	50/60 Hz ± 5%	50/60 Hz ± 5%
Ambient temperature	-10 to +140.00°F	-10 to +140.00°F
Enclosure protection	IP 54	IP 54
Operating mode	S3-50% ED	S3-50% ED
Set time	2,5 bzw. 5 s/mm	2,5 bzw. 5 s/mm
Actuating power	MC25x = 2,5 kN MC50x = 5 kN	MC25x = 2,5 kN MC50x = 5 kN
	The specified actuating power is only achieved in operation at 24 V DC with rectified AC voltage.	

Table 1 Technical data

<b>Input signal Y/ Input resistor (resistance of load)</b>	<ul style="list-style-type: none"> <li>• 0 ... 10 V DC / 77 k<math>\Omega</math></li> <li>• 2 ... 10 V DC / 77 k<math>\Omega</math></li> <li>• 0 ... 20 mA / 510 <math>\Omega</math></li> <li>• 4 ... 20 mA / 510 <math>\Omega</math></li> </ul>
<b>Output signal X/ Load capacity</b>	<ul style="list-style-type: none"> <li>• 0 ... 10 V DC / resistance of load <math>\geq</math> 1200 <math>\Omega</math>, <math>I_{\max}</math>. 8 mA</li> <li>• 0 ... 20 mA / resistance of load <math>\leq</math> 500 <math>\Omega</math> - with printed circuit board for output signal as optional extra <b>(111)</b></li> <li>• 4 ... 20 mA / resistance of load <math>\leq</math> 500 <math>\Omega</math> - with printed circuit board for output signal as optional extra <b>(111)</b></li> </ul>
<b>Feedback signal R/Load capacity</b>	<ul style="list-style-type: none"> <li>• 24 V DC / Minimum resistance <math>\geq</math> 480 <math>\Omega</math> / <math>I_{\max}</math>. 35 mA</li> </ul>
<b>Transmission resistance between B1 and B2</b>	<ul style="list-style-type: none"> <li>• max. 10 <math>\Omega</math></li> </ul>

Table 2 Technical Data Signals

## 2.6 Ratingplate

The rating plate is located on the linear actuator casing.

This includes the type designation and the fabrication number (F.No.) with the date of manufacture (last four digits).

⇒ 2.1 Components on page 6

		
<b>MC500/230</b>		
F.-Nr.: 07204142/01/0607		
AC 50 Hz 230 V	max. 25 VA	5 kN
Y=0...10 V DC	IP 54	5 s/mm
X=0...10 V DC	S3-50% ED	Stroke 60 mm

Diagram 4 Example of a rating plate

## 3 Transport and storage



### Risk of injury in the event of non-compliance with safety regulations!

- Wear the necessary personal and other safety equipment.
- Avoid knocks, shocks, vibrations and similar to the linear actuator.
- Store the linear actuator (and if necessary the complete actuating unit) in a dry place.
- Observe the transportation and storage temperature of -20 to +65° C.

## 4 Assembly

Prior to installation of the linear actuator:

- ⇒ 4.1 Check the scope of supply on page 12
- ⇒ 4.2 Prepare for installation on page 12

Installation of the linear actuator includes the following tasks:

- ⇒ 4.3 Mount linear actuator on valve on page 13
- ⇒ 4.4 Fit/remove cover on page 14
- ⇒ 4.5 Connect the electrics on page 15

### 4.1 Check the scope of supply

- 1 Check the packaging for damage.
- 2 Dispose of the packaging in an environmentally friendly manner.
- 3 Check against the delivery note that the delivery is complete.
- 4 Report any missing or damaged products to the manufacturer.

### 4.2 Prepare for installation



ATTENTION

#### Damage due to valve not being fitted!

If the linear actuator is operated without valve, then the spindle nut may fall out due to the missing stop.

- Therefore, only operate the linear actuator with a valve fitted.

- 1 Ensure that there is space of approx.200 mm above the cover at the installation site.
- 2 Check the working environment prior to fitting the linear actuator and commissioning:
- 3 Ensure that the valve is fitted correctly. See Valve Installation Instructions for further information.
- 4 Determine the installation position of the linear actuator. Linear actuators may not be installed in a suspended position.

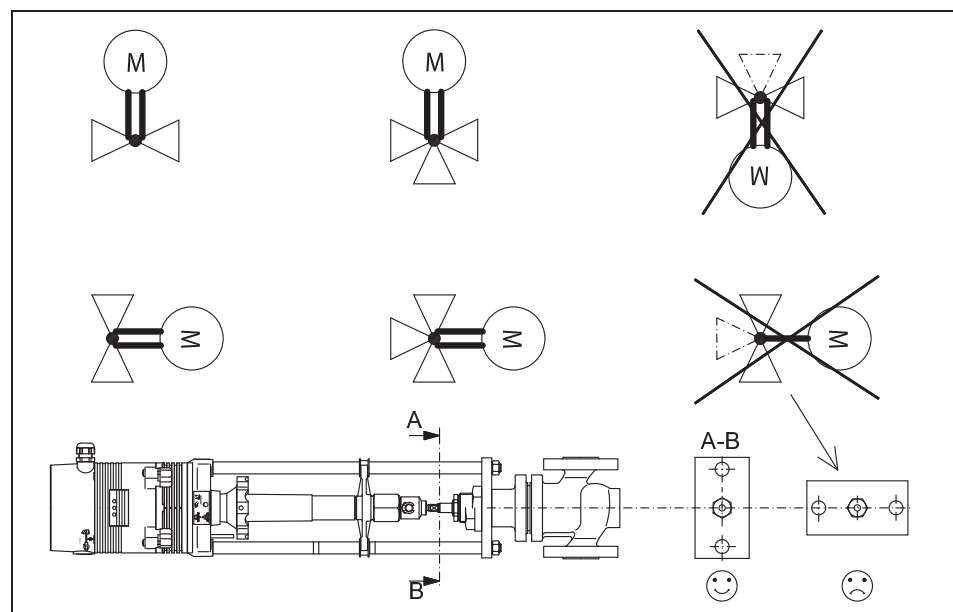
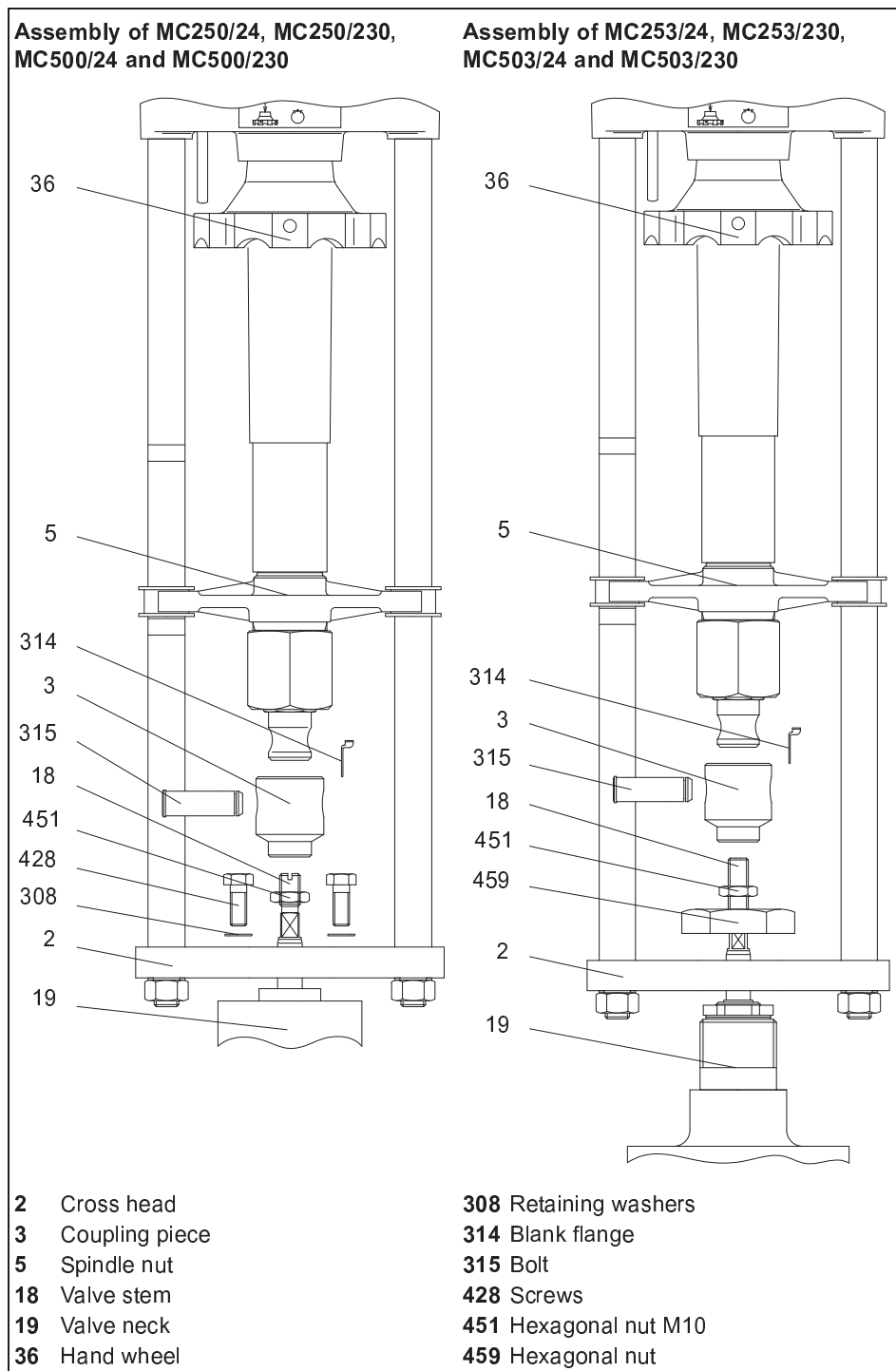

Diagram 5 Installation positions for linear actuator and valve

### 4.3 Mount linear actuator on valve

If the linear actuator and the valve are delivered separately, the linear actuator must then be mounted on the valve.



**Diagram 6** Mount linear actuator on valve

■ **Proceed as follows to install the linear actuator:**

- 1 Remove the blank (314) flange.  
⇒ *Diagram 6* on page 13
- 2 Remove the bolt (315) from the coupling (3) or force it out.

- 3 Rotate the hexagonal nut M10 (451) wrench size 17 onto the valve spindle (18).
  - 4 Rotate the coupling (3) onto the valve spindle (18).
  - 5 Use the flat hexagonal nut to lock the valve spindle (18) to secure it against distortion.
  - 6 Place the actuator with traverse (2) onto the valve neck (19).
  - 7 **For Types MC253, MC503:**  
Fix the traverse (2) with a hexagonal nut (459) wrench size 50.
  - 8 **For Types MC250, MC500:**  
Fix the traverse (2) of the actuator with screws (428) wrench size 13 and retaining washers (308) on the valve neck (19).
  - 9 Use the handwheel (36) to adjust the spindle nut (5) upwards so that the bolt(315) can be refitted.
  - 10 Fit the blank (314) flange!
- **Proceed as follows to dismantle the linear actuator:**
- 1 Carry out the installation sequence steps in reverse order.

#### 4.4 Fit/remove cover

The terminals for the electrical connection are located in the cover.



##### Electric shock due to live components!

If the power supply is switched off, there is danger of electric shock due to live components.

- Prior to starting work ensure that the actuator is disconnected safely from the mains power supply.
- Secure against unauthorised switching-on.
- Remove the cover only temporarily.

■ **Proceed as follows to remove the cover:**

- 1 Unlock the cover (201). Use a screwdriver (34) to turn the rotary knob counter-clockwise through 90° as far as the stop.

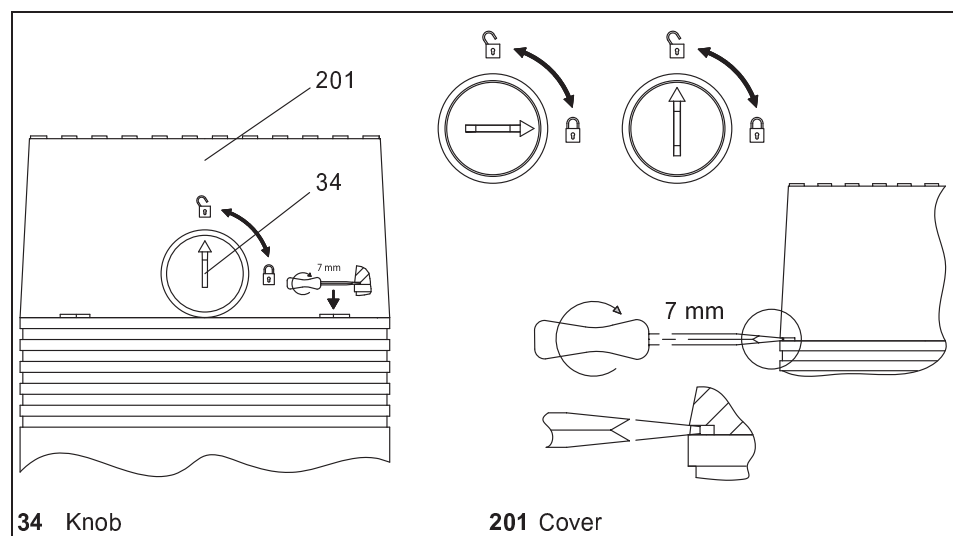

**Diagram 7** Remove cover

- 2 Insert a screwdriver into a groove in the cover and lift off the (201) cover.



### Damage to the equipment due to damaged wiring!

When removing the cover it is possible to tear or damage the wiring in the cover.

- Remove the cover carefully.

- 3 Remove the cover **(201)** carefully.
- 4 Disconnect the plug connection between motherboard **(110)** and cover **(201)**.

#### ■ Proceed as follows to replace the cover:

- 1 Insert the cables previously removed into the plug connector in the motherboard **(110)**.

Take care not to damage the grooves in the plug connector and bush.

**Hint:** The cover **(201)** can be fitted in four different positions offset by 90° respectively. This enables convenient laying of the connecting cable in the event of different installations of the linear actuator.

- 2 Put the cover **(201)** on and press it into place with moderate application of force.
- 3 Check the correct fit of the cover to ensure the tightness of the actuator casing.
- 4 Lock the cover **(201)**. Use a screwdriver **(34)** to turn the rotary knob clockwise through 90° as far as the stop.

## 4.5 Connect the electrics



### Danger of death if carried out by unqualified personnel!

Connection of the electrics by unqualified personnel may cause death, serious physical injury or considerable material damage as a result.

- Ensure that this work is only carried out by qualified personnel.

⇒ 1.3 *Personnel* on page 5



### Electric shock due to live components!

Once the power supply has been switched on, there is risk of electric shock due to live components.

- Prior to starting work ensure that the actuator is disconnected safely from the mains power supply.
- Secure against unauthorised switching-on.

#### ■ Proceed as follows to prepare for the power connection:

- 1 Ensure that the power supply concurs with the data on the linear actuator rating plate.
- 2 Design the cable profile in accordance with the actuator power and the necessary cable length in order to avoid operating faults.
- 3 Lay the mains cables for a power supply of > 48 V separately from the signal and control cables.

If the cables are laid in a common cable duct, screened control cables must be used.

4 Check the power supply voltage.

If the required tolerance of the power supply voltage cannot be maintained with a mains transformer, an AC voltage regulator must be used.

⇒ 2.5 Technical data on page 10.

■ **Proceed as follows to switch the electrics on:**

1 Remove the **(201)** cover.

⇒ Proceed as follows to remove the cover: on page 14.

2 Feed the cable through the screw connector in the cover to the terminal strip.

3 Connect the electrics in accordance with the circuit diagram.

⇒ Diagram 8 on page 16

**Hint:** The circuit diagram **(481)** is located on the printed circuit board cover **(33)**.



**Malfunction due to incorrect zero potential!**

If the linear actuator is electrically supplied by signal generators with different zero potentials, this may cause incorrect dynamic performance.

- Ensure that the zero potentials are correctly used.

⇒ Table 3 on page 17

4 Tighten the screw connections.

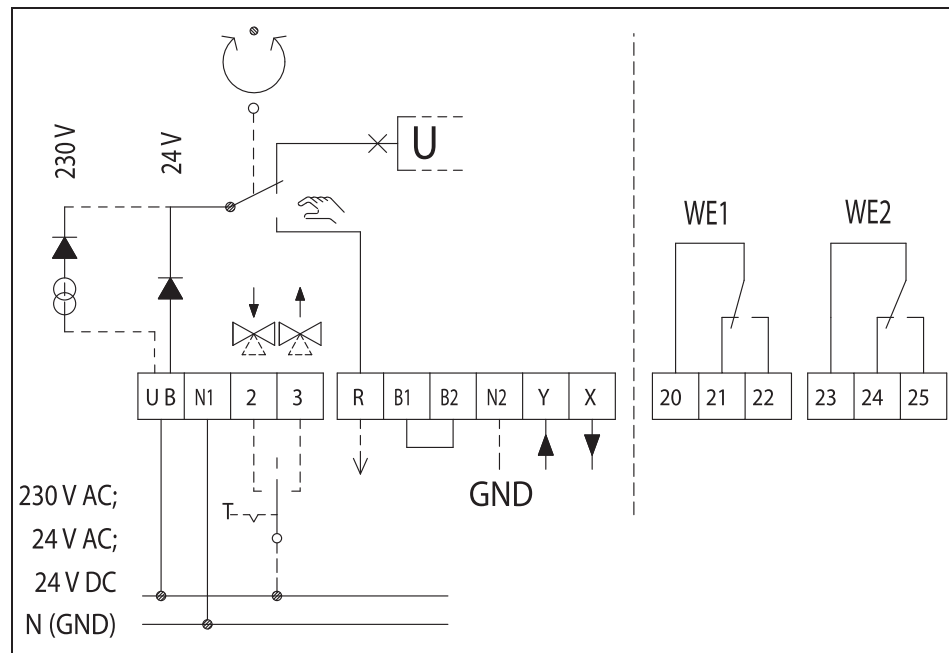

**Diagram 8** Wiring diagram

Terminal	Description
UB, N1	Supply voltage
2	Control voltage for downward movement in Three-point mode
3	Control voltage for upward movement in Three-point mode
R	Feedback signal in "Manual mode" • R= 24 V DC max. 35 mA
B1, B2	Binary input / Frost protection function
N2	Zero potential for signals X, Y and R • If the zero potentials for signals X, Y and R are identical to the zero potential for the power supply, terminals N1 and N2 can be bridged. • If the actuator is operated in Continuous mode at 230 V, N2 must be closed. • If the actuator is operated in Three-point mode at 230 V, N2 must be closed, if X and R also need to be used.
Y	Input signal for Continuous mode
X	Output signal for Continuous mode
20, 21, 22	Terminals for way-switch unit WE1
23, 24, 25	Terminals for way-switch unit WE2

**Table 3** Circuit diagram legend

#### 4.5.1 Control-independent switching

If operating with 24 V power supply and 0 ... 10 V DC / 2 ... 10 V DC input signal, the actuator can be switched to control-independent using the three-stage switch in the control cabinet.

■ **Proceed as follows to switch the actuator to control-independent:**

- 1 Connect the 24 V AC power supply via a diode and a three-stage switch to terminal Y.

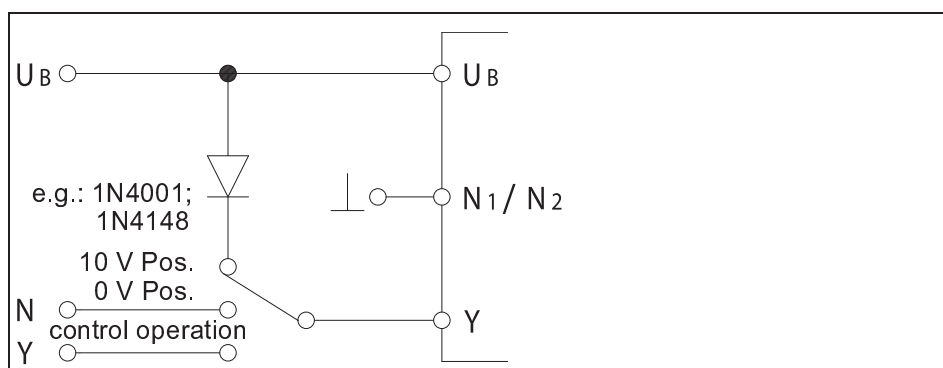

**Diagram 9** Control-independent switching

- 2 This switch can be used to move the linear actuator into the following positions:
    - Control mode through input signal Y (Normal mode)
    - 10 V-Position
    - 0 V-Position, at 2 ... 10 V DC the linear actuator can be moved to the position selected by coding switch S7.
- ⇒ 5.1 *Operating parameters and coding switch positions* on page 22  
5.7 *Set limit position* on page 25

### 4.5.2 Remove printed circuit board cover

The printed circuit board cover must be removed **(33)** first in order to adjust the linear actuator via the coding switches.



#### Electric shock due to live components!

If the power supply is switched off, there is danger of electric shock due to live components.

- Prior to starting work ensure that the actuator is disconnected safely from the mains power supply.
- Secure against unauthorised switching-on.

- 1 Insert a screwdriver into a groove in the cover **(201)** and lift the **(201)** cover out.
- 2 Insert a small screwdriver into the groove provided in the printed circuit board cover for this purpose **(33)** and remove it with care.

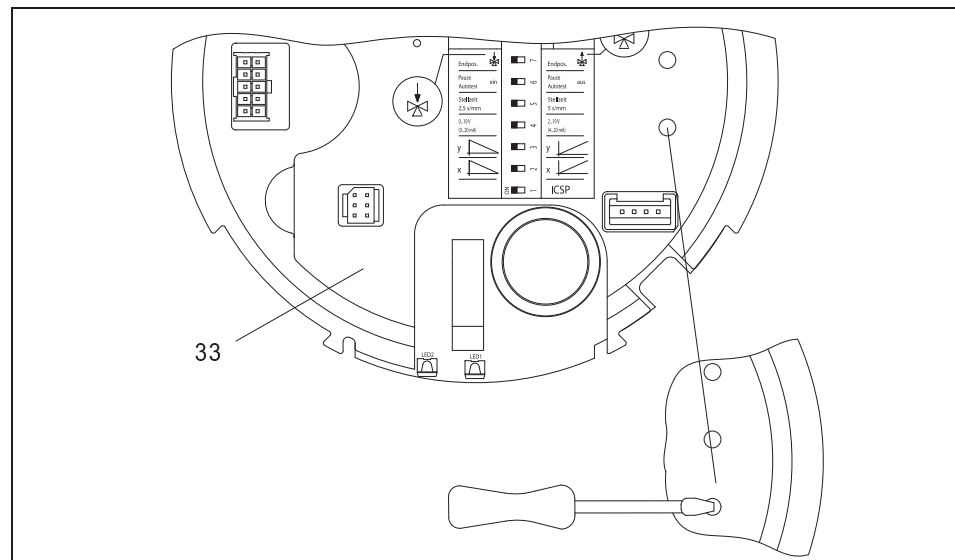

**Diagram 10** Remove the printed circuit board cover from the actuator casing.

- 3 Once the printed circuit board cover **(33)** has been removed from the actuator casing, **(1)** coding switches S1 to S10 will be accessible.

### 4.6 Optional extras installation

Optional extras are only part of the scope of supply of the linear actuator if expressly ordered! The linear actuators are prepared for retrofitting the following:

- Way-switch printed circuit board **(106)**
- Printed circuit board for output signal X=0/4 ... 20 mA **(111)**

⇒ 2.2 *Accessories* on page 7

### 4.6.1 Way-switch printed circuit board installation



#### Electric shock due to live components!

If the power supply is switched off, there is danger of electric shock due to live components.

- Prior to starting work ensure that the actuator is disconnected safely from the mains power supply.
- Secure against unauthorised switching-on.

- 1 Open the linear actuator **(201)** cover.  
⇒ 4.4 Fit/remove cover on page 14
- 2 Press the way-switch printed circuit board **(106)** onto the terminal board **(27)** using the **(107)** three spacers.

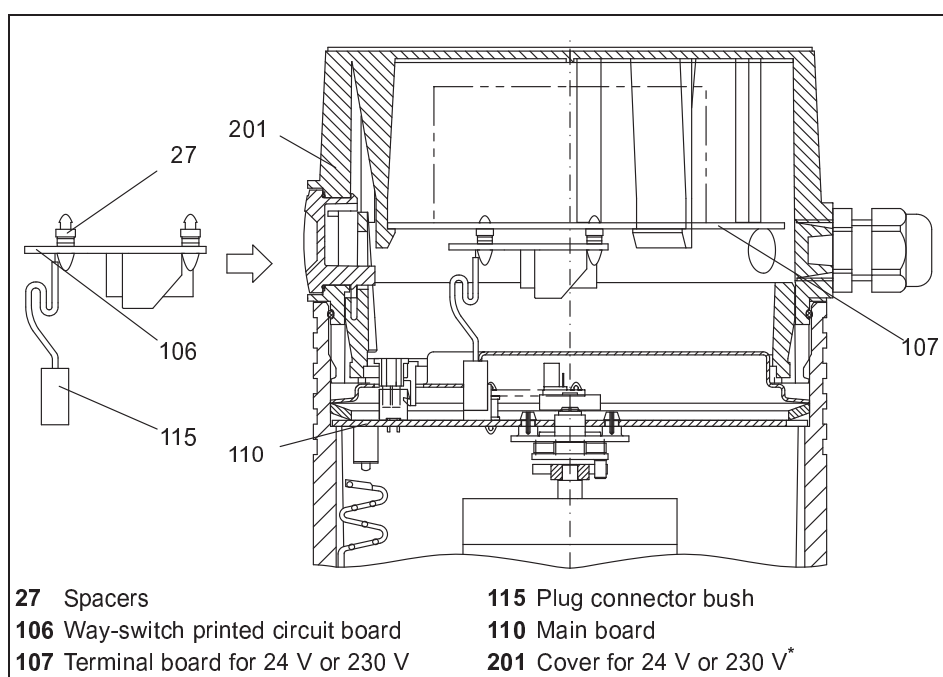

**Diagram 11** Installation of the way-switch printed circuit board in the cover

- 3 Place the plug connector bush **(115)** for the way-switch printed circuit board **(106)** on the pin strip **(123)** on the **(110)** motherboard. Pay attention to the grooves in the pin strip and plug connector bush.

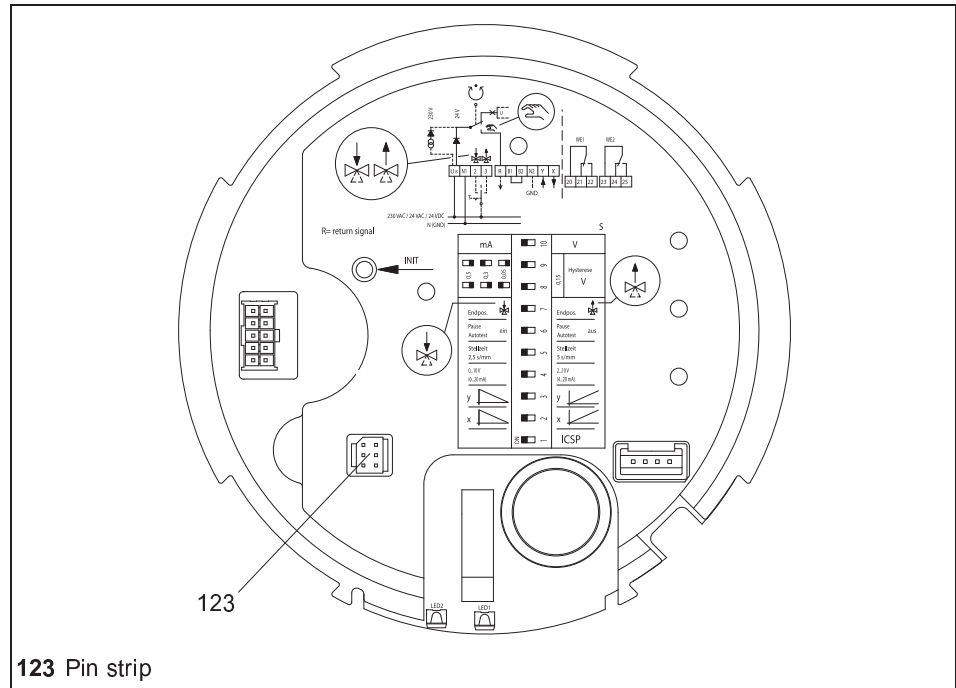

**Diagram 12** Pin strip for way-switch printed circuit board on the motherboard

- 4 Adjust the way-switch.  
⇒ 5.8 Set potential-free way-switch on page 25

#### 4.6.2 Fit the printed circuit board for mA output signal.



##### Electric shock due to live components!

If the power supply is switched off, there is danger of electric shock due to live components.

- Prior to starting work ensure that the actuator is disconnected safely from the mains power supply.
- Secure against unauthorised switching-on.

- 1 Open the cover (**201**) and remove the printed circuit board cover(**481**).  
⇒ 4.4 Fit/remove cover on page 14  
⇒ 4.5.2 Remove printed circuit board cover on page 18
- 2 Remove the jumper (**JP1**) from the motherboard (**110**).
- 3 Put the jumper (**JP1**) onto the plug-in bridge (**113**) for the printed circuit board for mA output signal.
- 4 Plug the printed circuit board for mA output signal (**111**) together with its pin strip into the plug-in bridge (**113**) on the motherboard (**110**).
- 5 Lock the spacers (**27**) into the holes in the motherboard.

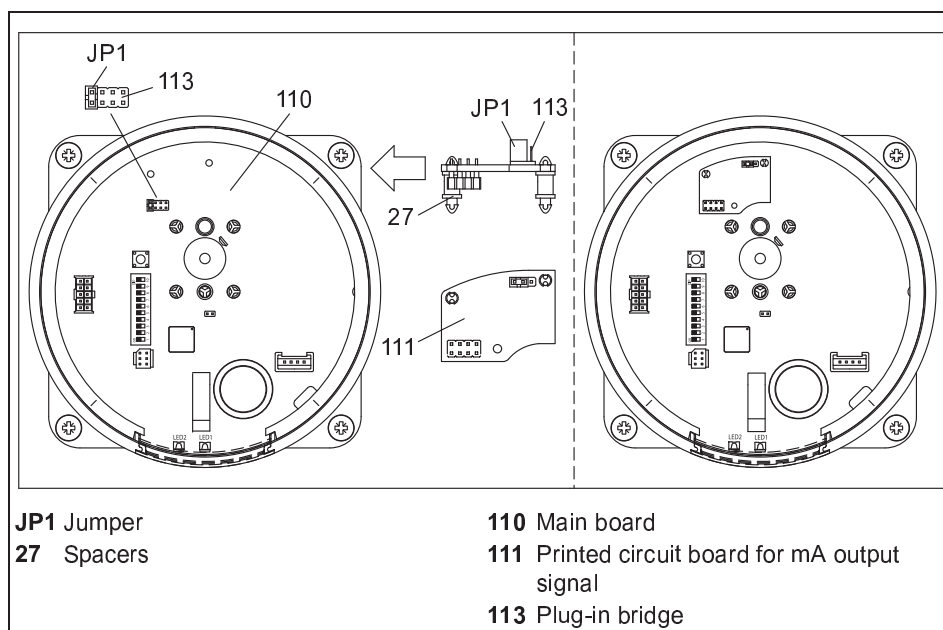

**Diagram 13** Installation of the printed circuit board for mA output signal

**6** Select the output signal range with the jumper (**JP1**):

- Jumper right: 0 ... 20 mA
- Jumper left: 4 ... 20 mA

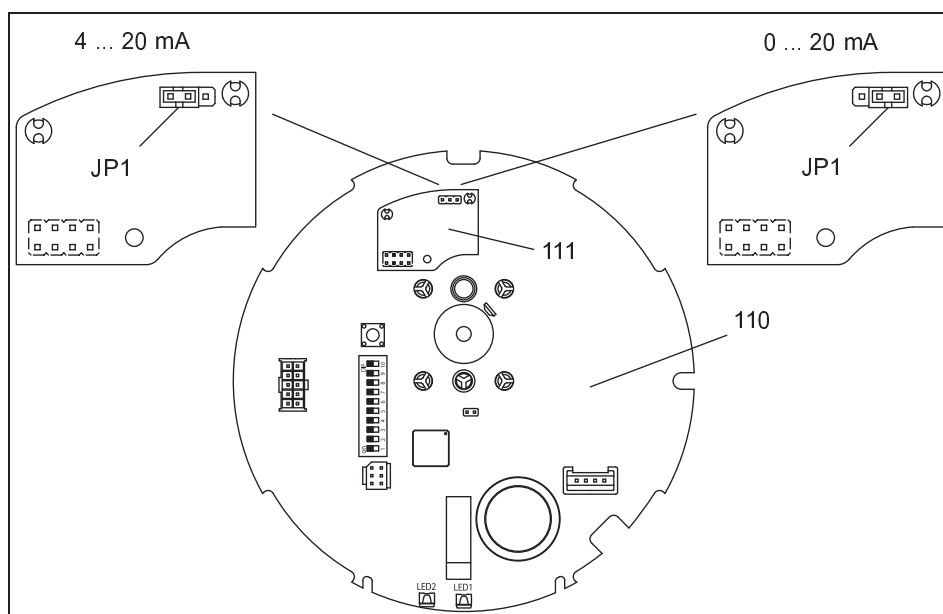

**Diagram 14** Set signal range for mA output signal X

## 5 Commissioning



### Electric shock due to live components!

If the power supply is switched off, there is danger of electric shock due to live components.

- Prior to starting work ensure that the actuator is disconnected safely from the mains power supply.
- Secure against unauthorised switching-on.

The operating parameters are set (**116**) on the coding switches. The coding switches are located under the printed circuit board cover (**33**) in the actuator casing (**1**).

⇒ 4.4 Fit/remove cover on page 14

⇒ 4.5.2 Remove printed circuit board cover on page 18

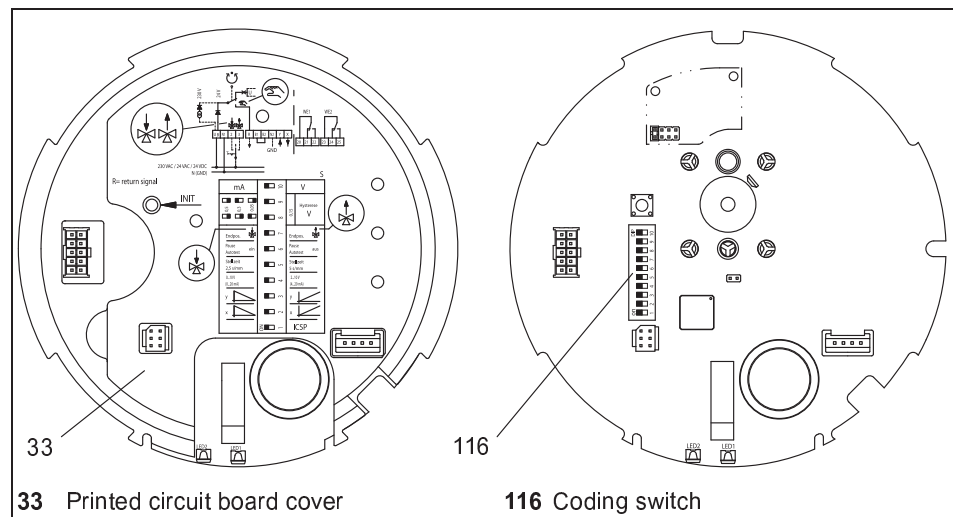

**Diagram 15** Printed circuit board cover and coding switches

### 5.1 Operating parameters and coding switch positions

The operating parameters must be set with the coding switches before the linear actuator can be operated.



### Malfunctions due to incorrect switch position S1

Switch S1 must always be at "on".

- Ensure that switch S1 is at "on".

Switch	on	off
S1	Ready for operation	-
S2	X characteristic curve 	X characteristic curve 
S3	Y characteristic curve 	Y characteristic curve 
S4	Input signal (Y) 0 ... 10 V DC or 0 ... 20 mA	Input signal (Y) 2 ... 10 V DC or 4 ... 20 mA
S5	Actuating time 2.5 s/mm	Actuating time 5 s/mm
S6	Autotest and Autopause on	Autotest and Autopause off
S7	Limit position for actuator spindle extended	Limit position for actuator spindle retracted
S8, S9	The hysteresis (0.05 ... 0.5 V) is set using S8 and S9.	
S10	Input signal (Y) in mA	Input signal (Y) in V

Table 4 Coding switch positions

## 5.2 Set input signal

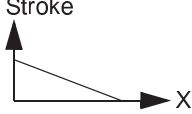
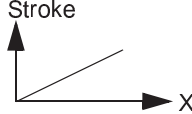
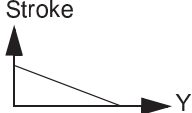
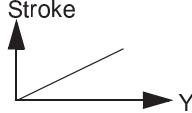
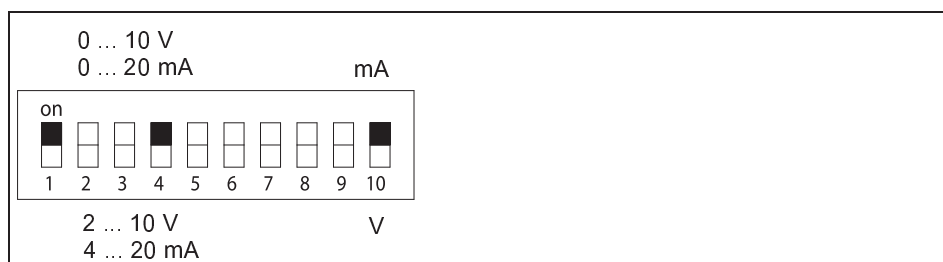

Diagram 16 Set input signal

⇒ Further information: *Input signal (Y)* on page 8

## 5.3 Set actuating time

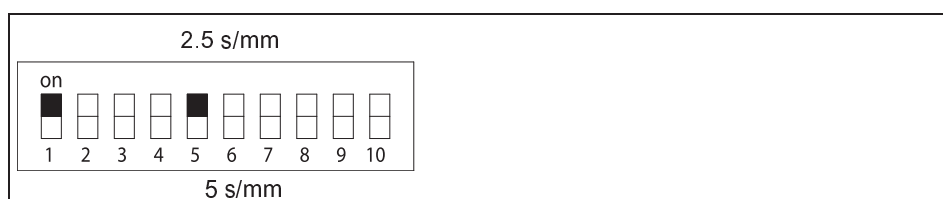

Diagram 17 Set actuating time

⇒ Further information: 2.4.5 *Set time* on page 9

## 5.4 Set hysteresis

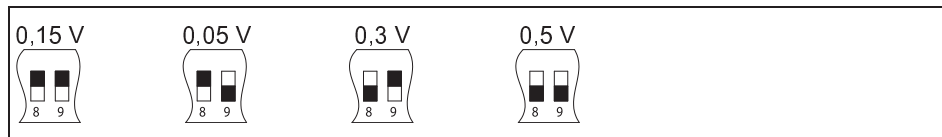

Diagram 18 Set hysteresis

⇒ For further information 2.4.6 *Hysteresis* on page 9

## 5.5 Set actuating direction

The actuating direction of the linear actuator can be reversed at the coding switch (inverted operation).

Actuator position	Normal operation	Inverted operation (X and Y inverted)
<b>Coding switch S2: X (output signal), coding switch S3: Y (input signal)</b>		

Table 5 Set actuating direction

## 5.6 Set Autotest and Autopause

If coding switch S6 is at ON, Autotest and Autopause are active.

Approaching the limit switch in rapid traverse is triggered approx. every 10 days in Autotest. A new zero balance is carried out automatically.

A 3-second pause (2-minute measuring cycle) is carried out in Autopause after more than 20 actuator commands in different directions per minute.

It is not possible to select these two functions separately.

## 5.7 Set limit position

Select the limit position for the linear actuator using coding switch S7:

- S7 ON: Limit position with extended spindle nut
- S7 OFF: Limit position with retracted spindle nut

The limit position is approached in the following situations:

- In the event of open-circuit detection by the Y signal (only for 2 ... 10 V DC or 4 ... 20 mA),
- In the event of a binary signal (circuit is broken between terminals B1 and B2),
- in Autotest,
- upon disruption of the power supply (manual adjustment).

## 5.8 Set potential-free way-switch

Set the two way-switches via trimmer potentiometers P1/P2 independently from one another. Carry out the specified working steps for each way-switch once.

### ■ Proceed as follows to set a way-switch:

- 1 Ensure that the linear actuator has been started up and initialised.

⇒ 5.10 Commissioning on page 28

5.9 Initialise the path-measuring system on page 27



### Malfunction due to inaccurately set way-switch!

If the actuator has been set to Manual mode (without power supply), the way-switch can only be set inaccurately (Centre position of the arm corresponds to the switching point for approx. 50% lift in this instance).

- Switch the actuator to Automatic mode in order to set the way-switch accurately.

- 2 Move the actuator into a position where a switching event should be triggered. The following working steps must be carried out with the power supply switched on.



### Electric shock due to live components!

Once the power supply has been switched on, there is risk of electric shock due to live components.

- Take care not to touch any live components.
- Take care not to cause a short circuit on a printed circuit board with the tool.

- 3 Open the cover **(201)**.  
⇒ 4.4 Fit/remove cover on page 14  
The way-switch printed circuit board is located in the cover **(106)**.
- 4 Use a screwdriver to turn the trimmer potentiometer until the way-switch switches. The associated LED goes on or off during this operation.  
Use potentiometer P1 **(105 P1)** to set way-switch 1.  
LED 1 indicates the switching status.  
Use potentiometer P2 **(105 P2)** to set way-switch 2.  
LED 2 indicates the switching status.

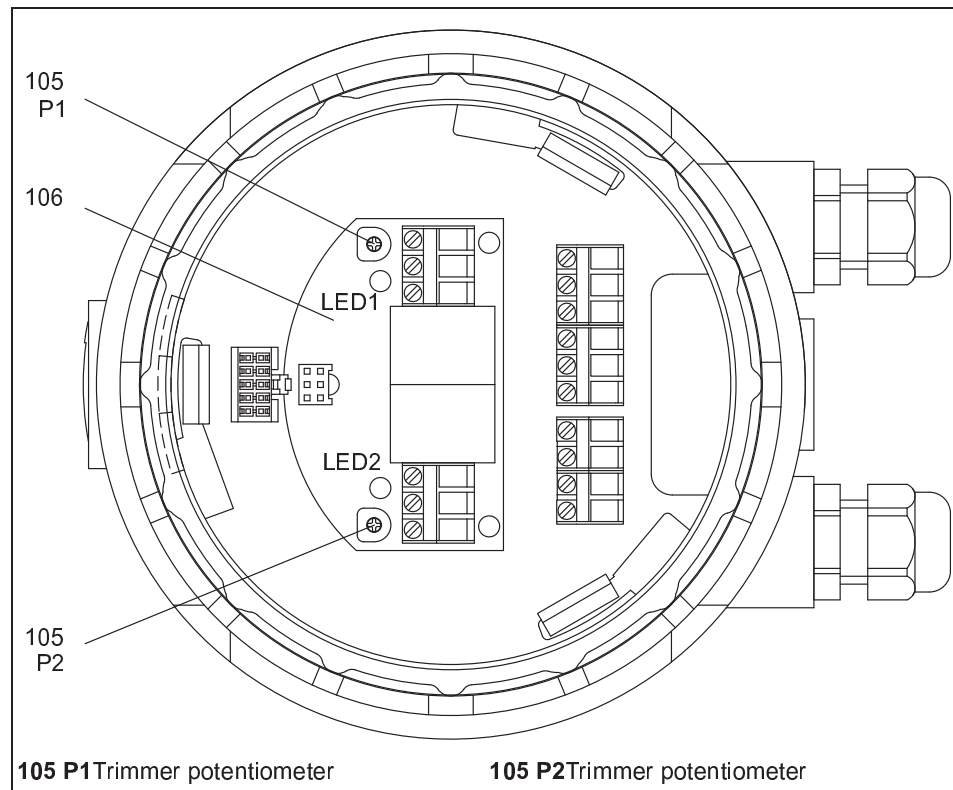

**Diagram 19** Way-switch printed circuit board in cover

- 5 Observe the permitted way-switch contact load:

<b>Nominal load</b>	8 A, 250 V AC 8 A, 30 V DC
<b>Switching voltage</b>	max. 400 V AC max. 125 V DC

**Table 6** Way-switch contact load

- 6 Switch off the power supply to the actuator and connect the way-switch contacts.
- 7 Close the linear actuator **(201)** cover  
⇒ Proceed as follows to replace the cover: on page 15

## 5.9 Initialise the path-measuring system



### Linear actuator starts up automatically!

Immediately upon connecting the power supply, the linear actuator moves automatically to a path-measuring system reference point.

- Wait until the reference point has been reached and the linear actuator stops.

The incremental path-measuring system must be initialised upon completion of the following tasks:

- In the event of initial start-up
- After repairs to the valve or the actuator
- After changing the valve or the actuator

The initialisation can be triggered in two ways.

#### ■ Proceed as follows to initialise via the initialising button



### Electric shock due to live components!

Once the power supply has been switched on, there is risk of electric shock due to live components.

- Take care not to touch any live components.
- Take care not to cause a short circuit on a printed circuit board with the tool.

- 1 Open the cover **(201)**.  
⇒ 4.4 Fit/remove cover on page 14
- 2 Ensure that the power supply is on.
- 3 Press the initialising button **(118)** and keep it depressed for at least 1 second.

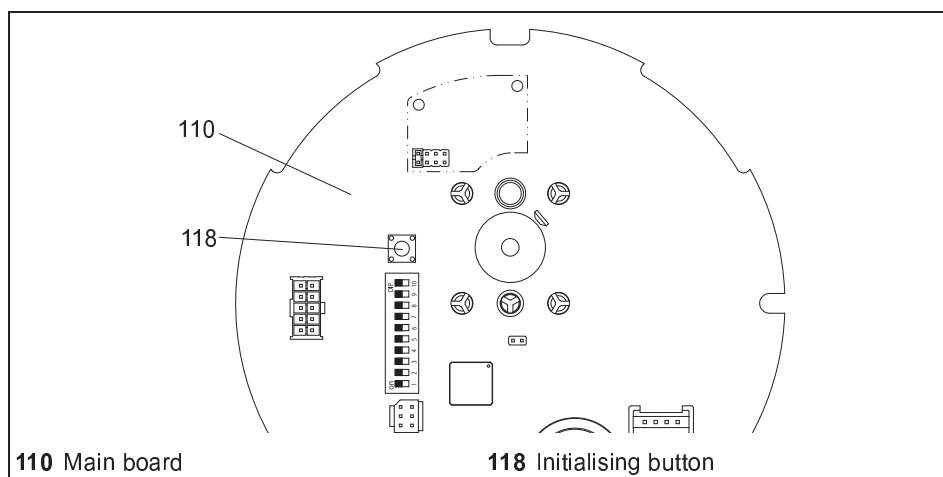

**Diagram 20** Initialise the path-measuring system

#### ■ Proceed as follows to initialise via the connecting terminals

- 1 Connect the power supply simultaneously to terminals 2 and 3. Ensure that the power supply remains on for at least 1 second.  
⇒ *Diagram 8* on page 16

### 5.10 Commissioning

- 1 Check that all installation and assembly tasks have been completed correctly.  
⇒ *4 Assembly* on page 12
- 2 Ensure that the electric actuation of the linear actuator is ensured without danger to persons or equipment or the system.
- 3 Ensure that the linear actuator is correctly fixed and the linear actuator cover is closed.  
⇒ *4.4 Fit/remove cover* on page 14
- 4 Ensure that the linear actuator is switched to Automatic mode.  
⇒ *6.1 Switching between Manual and Automatic modes* on page 29
- 5 Ensure that the operating parameters have been correctly set.  
⇒ *5.1 Operating parameters and coding switch positions* on page 22
- 6 Ensure that the path-measuring system has been initialised.  
⇒ *5.9 Initialise the path-measuring system* on page 27
- 7 Connect the power supply. Then the linear actuator moves to the reference point.  
The linear actuator is ready for operation.

## 6 Operation

Before the linear actuator can be operated, it must be initialised and the operating mode selected.

⇒ 5 Commissioning on page 22

5.9 Initialise the path-measuring system on page 27

### 6.1 Switching between Manual and Automatic modes

The linear actuator can be operated in Automatic mode or in Manual mode (manual adjustment).

- In Automatic mode the spindle nut moves into the position specified by the control.
- In Manual mode the spindle can be adjusted manually, e.g. for inspection purposes. The output signal (X) is not available in Manual mode.

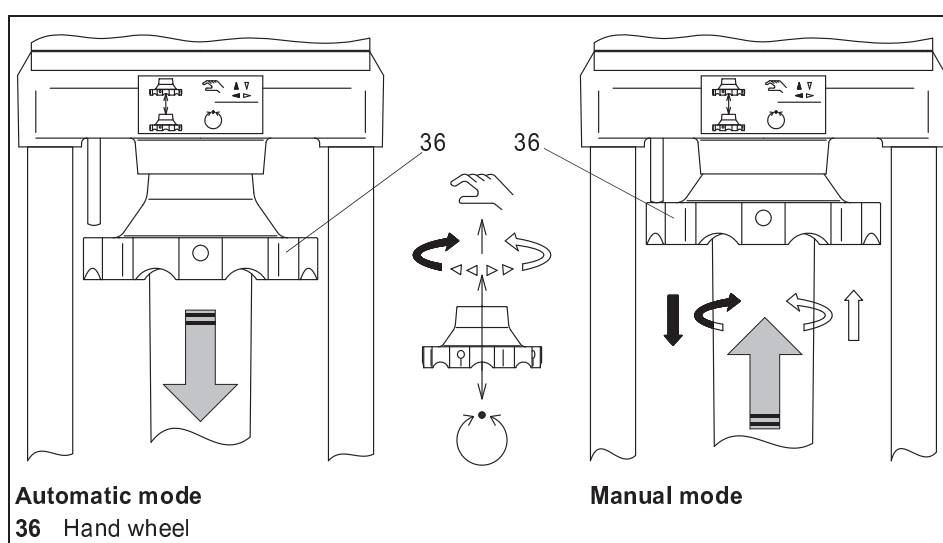

**Diagram 21** Select Automatic mode

#### ■ Proceed as follows to switch to Manual mode

- 1 Move the handwheel (36) into the manual mode position and rotate it until the handwheel locks.



#### **Risk of damage to valve and actuator in Manual mode!**

The valve can get damaged if it is pressed too firmly into its seat when closing in Manual mode.

- Do not rotate the handwheel any further if the amount of effort needs to be increased!
- Never use force.

- 2 Use the handwheel to rotate the spindle nut into the required position. Rotate the handwheel until the rotational resistance increases. Do not use force!

#### ■ Proceeds as follows to switch to Automatic mode

- 1 Move the handwheel (36) into the automatic mode position.
- 2 The linear actuator moves first of all into the position specified by coding switch S7 and then into the position specified by the control.

## 6.2 LED display

The LEDs in the viewing window (47) indicate operating states or faults.

⇒ 10.2 Operating faults checklist on page 32









Green LED	Operating status / fault
 duration	<b>Normal operation, standby</b> The LED illuminates continuously, actuator awaits drive command.
 ⊗  ⊗ 0,5s 0,5s 0,5s 0,5s	<b>Standard Operation</b> Actuator carries out drive command.
 ⊗  ⊗ 0,2s 1,5s 0,2s 1,5s Short - long rhythm	<b>Open-circuit detection</b> In operating modes 2 ... 10 V DC or 4 ... 20 mA, the input signal has dropped below 1 V or below 2 mA. ⇒ 2.4.4 Open-circuit detection on page 9
 ⊗  ⊗ 2,5s 2,5s 2,5s 2,5s Long - long rhythm	<b>Lock detection (only in Continuous mode)</b> The linear actuator is mechanically locked. ⇒ 2.4.2 Lock detection on page 8
 ⊗  ⊗ 1,5s 0,2s 1,5s 0,2s Long - short rhythm	<b>Continuous signal on terminals 2 and 3</b> An initialisation run starts in the event of simultaneous control signal on terminals 2 and 3 (max. 4 attempts). The linear actuator switches off automatically after 4 failed attempts.

Table 7 Green LED display





Red LED	Operating status / fault
 OFF	<b>Temperature within normal range</b>
 duration	<b>Heating operation</b> ⇒ Actuator heating on page 9
 ⊗  ⊗ 0,25s 0,25s 0,25s 0,25s Flashes regularly	<b>Actuator overheats</b> ⇒ Overheating protection on page 8

Table 8 Red LED display

## 7 Maintenance, Care and Repairs

The linear actuator is low-maintenance. No routine or periodic maintenance is required.

## 8 Spare parts

Check the data on the linear actuator rating plate when ordering optional extras or spare parts. The data on the rating plate is decisive for linear actuator technical data and mains power supply requirements.



### Equipment damage due to defective spare parts!

Spare parts must comply with the technical requirements specified by the manufacturer.

- Use only original spare parts.

⇒ 2.1 *Components* on page 6

⇒ 2.2 *Accessories* on page 7

## 9 Shutdown and Disposal

Dispose of the linear actuator in accordance with national regulations and legislation.

## 10 Troubleshooting

The path-measuring system needs to be re-initialised after troubleshooting.

⇒ 5.9 *Initialise the path-measuring system* on page 27

### 10.1 Troubleshooting

If the linear actuator does not work perfectly, proceed as follows to eliminate the fault:

- 1 Check that the linear actuator was installed correctly.
- 2 Check the linear actuator settings and the rating plate data.
- 3 Eliminate the faults using the checklist.  
⇒ 10.2 *Operating faults checklist* on page 32
- 4 If this fault still cannot be eliminated, contact the manufacturer.
- 5 Please quote the following for all queries and returning goods to the manufacturer:
  - F-No. (Fabrication No. = Contract No.)
  - Type designation
  - Power supply and frequency
  - Additional equipment
  - Error report
- 6 If the fault cannot be eliminated by the inquiry, the equipment can be returned to the manufacturer.

## 10.2 Operating faults checklist

Fault	Cause/reason	Remedy
1. Linear actuator does not work.	Handwheel (36) is in manual mode position	<input type="checkbox"/> Switch handwheel to automatic mode position.
	Mains power failure	<input type="checkbox"/> Establish cause and eliminate.
	Fuse defective. (in the electrical cabinet)	<input type="checkbox"/> Establish cause and eliminate, change fuse.
	Linear actuator incorrectly connected	<input type="checkbox"/> Rectify connection in accordance with circuit diagram (on the cover).
	Short circuit due to humidity	<input type="checkbox"/> Establish cause, dry the linear actuator, change hood seal and screw connections if necessary ad/or fit protective hood.
	Short circuit due to incorrect connection	<input type="checkbox"/> Rectify connection
2. Linear actuator runs in an unstable manner, i.e. switches between clockwise and counter-clockwise rotation.	Motor has coil damage (burnt out) <ul style="list-style-type: none"> <li>• e.g. due to too high voltage</li> <li>• Electronic system defective</li> </ul>	<input type="checkbox"/> Establish cause, measure current data Compare with rating plate and table, Remove linear actuator and return to manufacturer for repair.
	Voltage drop due to too long connecting cables and/or too small cross-section.	<input type="checkbox"/> Measure linear actuator current data, recalculate and change connecting cables if necessary.
3. Linear actuator cuts out from time to time or initialises frequently.	Mains power fluctuations greater than permissible tolerance ⇒ 2.5 <i>Technical data</i> on page 10	<input type="checkbox"/> Improve mains power ratios
	Supply cable has loose contact	<input type="checkbox"/> Check and tighten connections (terminal strips)
4. Linear actuator does not move to the limit positions. Valve does not close/open.	Valve jams	<input type="checkbox"/> Ensure smooth running valve
	Too high system pressure	<input type="checkbox"/> Correct system pressure
5. Linear actuator does not move or does not move correctly to the position specified by input signal Y.	Input signal Y faulty: <ul style="list-style-type: none"> <li>• Error signals</li> <li>• Signal fluctuations</li> </ul>	<input type="checkbox"/> Check input signal Y on linear actuator, eliminate cause of fault
	Motherboard faulty	<input type="checkbox"/> Change motherboard, remove linear actuator and return to manufacturer for repair if necessary.
6. Green LED flashes in long / long rhythm	Lock detection has responded	<input type="checkbox"/> Press INIT and observe actuator during initialisation.
		<input type="checkbox"/> Check valve for smooth running over entire lift range.
7. Green LED flashes in short / long rhythm	Open circuit detected	<input type="checkbox"/> Measure reference value voltage or current on linear actuator.
8. Green LED flashes in long / short rhythm	Relay contact adherence	<input type="checkbox"/> Check control
9. Red LED flashes regularly	Actuator overheats	<input type="checkbox"/> Motor has switched off automatically. Automatic start-up after cooling down

**Table 9** Operating faults checklist