

Assembly Instructions and Handling Regulations for

KLINGER

Piston Valves

KVN DN 65 – 150 PN 16 – I/III

with valve ring "KX-GT Modul"

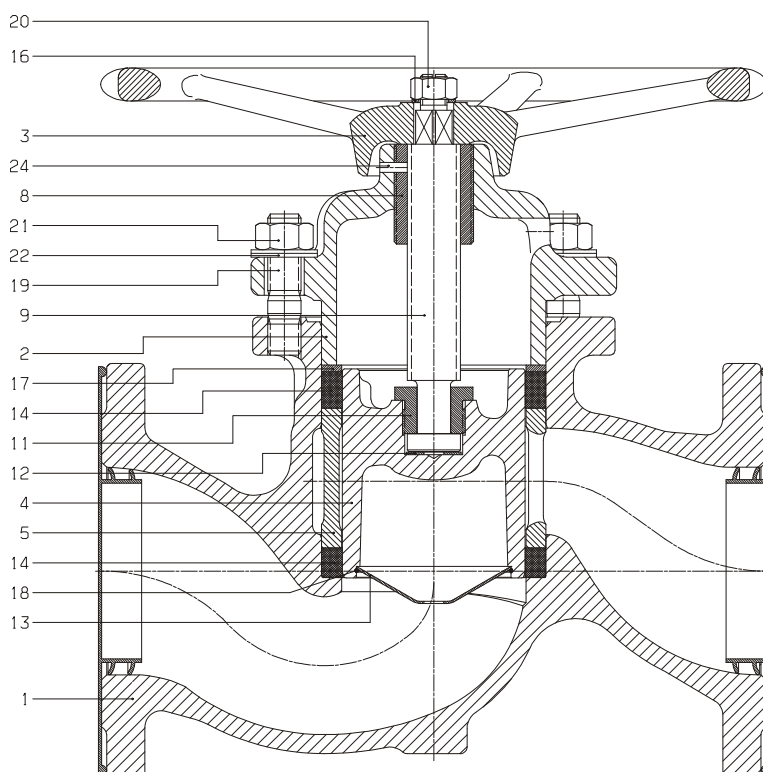

- 1 Body
- 2 Bonnet
- 3 Hand wheel
- 4 Piston
- 5 Lantern bush
- 8 Threaded bush
- 9 Stem
- 11 Split nut
- 12 Disc
- 13 Piston nose cone
- 14 Valve ring KX-GT
- 16 Serrated lock washer
- 17 Washer
- 18 Wire ring
- 19 Stud bolt
- 20 Hexagon nut
- 21 Hexagon nut
- 22 Belleville washer
- 24 Tension pin

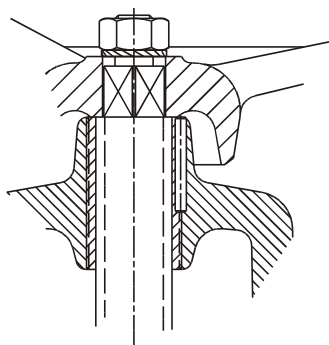

DN 125 - 150

DN 65, 80 and 100

Edition: 08/2004

Rev.: 03/2010



Fluid Control GmbH
Am Kanal 8-10
A-2352 Gumpoldskirchen/AUSTRIA

Telefon: ++43(0) 2252 / 600 0
Telefax: ++43(0) 2252 / 63336
 ++43(0) 2252 / 600 - 242
e-mail: office@klinger.kfc.at
WEB: www.klinger.kfc.at

CONTENTS

<i>Page 3</i>	<i>Storage Regulations</i>
<i>Page 4 and 5</i>	<i>Installation and Commissioning</i>
<i>Page 5</i>	<i>Operating Instructions</i>
<i>Page 6</i>	<i>Servicing and Important Information</i>
<i>Page 6</i>	<i>Notes on Hazardous Operating Errors and Sources of Danger</i>
<i>Pages 7, 8 and 9</i>	<i>Maintenance and Repair Instructions</i>
<i>Page 10 and 11</i>	<i>Illustrations for Assembly</i>
<i>Page 12</i>	<i>Data Sheet (Tightening Torques)</i>
<i>Page 13</i>	<i>Spare Parts Data Sheet</i>

Storage Regulations for KLINGER PISTON VALVES and Spare Parts

Store valves and spare parts in dry storerooms only. Fully assembled valves must be stored in delivery condition (valve in closed position, end connections fitted with protective caps). Valve spare parts must be handled with care and should, where possible, be kept in their original packaging during storage.

If cover film or shrink wrapping is used, take the necessary steps to ensure that there is no condensation in the air inside the covering.

Appropriate measures must be taken to protect the equipment in dusty environments.

To avoid confusion, all parts stored must be labelled as on the delivery note and stored in the correct place.

Temperatures in the storeroom must not exceed the limit values of -20°C and $+50^{\circ}\text{C}$ and rapid changes in temperature (causing condensation and perspiration) should be avoided.

Handling Regulations and Operating Instructions are supplied with, and should always be stored with, the products to ensure that important information and documents are appropriately passed on.

There are special Components Technical Data Sheets (Page 13) to aid identification of Klinger spare parts.

Our customers will be notified by circular letter of any modifications that affect storage requirements.

Klinger accepts no liability derived from guarantees, warranties, and product liability legislation for damage suffered by products due to incorrect storage.

Installation and Commissioning Regulations for KLINGER PISTON VALVES (KVN Model)

Please bear in mind the general hazard notes of Klinger valves (see document wT2792.11....)

Klinger piston valves can be installed in any position in the piping system. The preferred through flow direction (indicated by an arrow on the body) should, however, be observed.

Note: *Before installation protective caps must be removed from both sides of valve body*

Attention: *Piston valves show a piston pump effect while closing. This can result in increased pressure at the inlet side when used in the preferred flow direction. When used with piston pumps and non-return valves, piston valves should therefore be installed opposed to the preferred through flow direction.*

(see Fig. 1 below)

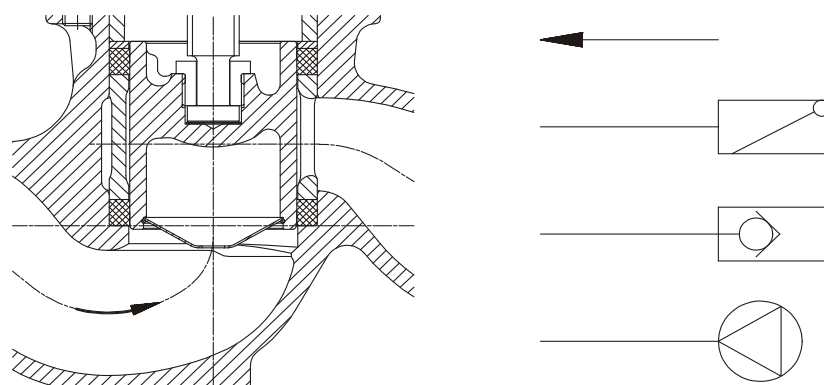

Fig. 1

Direction of flow

No special maintenance is required after commissioning valves with the KX-GT module since the rings do not set like conventional, soft-sealing valve rings.

*For recommended tightening torques see **Technical Data Sheet Page 12***

Klinger piston valves have a very rugged body. However, it is still important to ensure that plant-side connections lie parallel and true to axis.

Note: *If the line and valve are subsequently insulated, the insulation should only extend as far as the head flange on the body side so that access to the bonnet hexagon nuts is not impeded. Since the valve body can remain in site for repairs and maintenance work, the valve insulation does not need to be removable.*

Klinger accepts no liability relating to guarantees, warranties, and product liability legislation for damage caused by incorrect installation and failure to observe the commissioning regulations.

Operating Instructions for KLINGER PISTON VALVES (KVN Model)

Klinger piston valves must be closed clockwise and opened anticlockwise.

When closing the valve the hand wheel should be turned until it rests on the bonnet. Unlike globe valves, piston valves do not require increased final torque. Due to the design of piston valves, a seal may be achieved before the closed position is reached. To protect the valve rings, piston valves must always be closed as far as they will go.

Because Klinger piston valves can also be used to regulate and throttle, the above does not apply when opening the valve or setting it to the open position for regulating or throttling purposes.

Through flow characteristics for valve throttle positions are available from Klinger on request.

*If a valve starts leaking, check the tightening torques of the bonnet fastening nuts (21) referring to the table on page 12 and tighten if necessary. For this the valve needs to be in **CLOSED** position.*

Klinger accepts no liability relating to guarantees, warranties and product liability legislation for damage caused by failure to observe the operating instructions.

Recommended preventative maintenance to obtain the best possible service life from KLINGER VALVES

As with all spindle-operated mechanisms, **regular lubrication with Metaflux Lubricating Metal Paste 70-85** increases the life of the spindle (Pos.9). In addition, the coupling moment will be decreased when the spindle is well lubricated.

At temperatures above 50°C the spindle must be lubricated at least once a month or after 500 operations.

Especially the split screwed connection should be lubricated.

Hazardous Operating Errors and Possible Sources of Danger

Where the process fluid is incompressible, the operating of piston valves can cause pressure changes in tightly sealed parts of the system. This should be taken into account especially during the planning stage and the problem avoided by selecting suitable installation positions (see Page 4 Fig. 1).

Piston valves provide a particularly good seal. During temperature changes, process fluid captured between two piston valves can cause considerable changes in pressure which may exceed the pressure category of the valve. In such cases, appropriate volume compensation (expansion tank) is necessary.

Always ensure that the correct tightening torque specified in the Technical Data Sheet on Page 12 is applied to the bonnet hexagon nuts. Do not loosen or undo these nuts while the valves are under pressure.

The valves must not be subjected to pressure shocks in excess of one and a half times their rated pressure.

When the stem thread becomes so worn that its stability seems endangered, release the pressure on the valve and carry out the necessary maintenance.

Valves made of cast iron are particularly susceptible to brittle fracture and impact damage. This should be borne in mind when choosing materials.

Whatever the application, always consult the operating limits diagram (pressure-temperature) and also consider the suitability of the materials for various process fluids.

Maintenance and Repair Instructions for KLINGER PISTON VALVES (KVN Model)

Klinger piston valves are easy to repair using simple assembly and dismantling tools. The valve does not have to be removed, but the line system must be depressurised and emptied.

We recommend the following procedure for dismantling:

- *Depressurise and empty the system*
 - *Open the valve fully*
 - *Unscrew the bonnet fastening nuts (Pos.21), then disassemble Belleville washers (Pos.22)*
 - *Turn the hand wheel (Pos.3) clockwise (closing direction) (bonnet rises out of body)*
 - *Turn bonnet (Pos.2) slightly until the flange rests against the stud bolt face (Pos.19) and turn hand wheel anti-clockwise (opening direction) until piston (Pos.4) is completely free of valve ring (Pos.14), (see Page 10 Fig.2)*
 - *Remove bonnet together with hand wheel, stem and piston*
 - *Remove washer (Pos.17) and pull out upper valve ring (Pos.14) using the ring extractor hook, (see Page 10 Fig.3)*
 - *Remove lantern bush (Pos.5) using lantern bush extractor, (see Page 10 Fig.4)*
 - *Remove bottom valve ring (Pos.14) with ring extractor hook *)*
- *) Be careful not to damage the bore of the valve body**
- *Clean the valve body bore and valve ring seat, if necessary with fine sandpaper*

Note: *No sandblast*

We recommend the following procedure for reassembly:

- Mount bottom valve ring (Pos.14) using mounting tool (see Page 11 Fig. 5 for DN 65 and 80), (Fig. 7 for DN 100 – 150 *)
- Replace the cleaned lantern bush (**)
- Mount the top valve ring (Pos.14) using mounting tool
- Insert washer (Pos.17)

Attention: Particular care should be taken to ensure that the rings are inserted correctly positioned into the bore of the valve body using the mounting tool

*) Do not use lubricant or grease

***) Replace lantern bush ensuring that no teeth are on the valve outlet side (Kv valve optimisation)

Attention: Whenever the valve ring is replaced, always check at the same time that the piston/stem/bonnet assembly is functioning properly. Check that:

- a) the outer cylinder surface of the piston and piston shaft is smooth and unmarked
- b) the stem head moves freely in the two-part union piece
- c) the trapezoid thread of the stem is not unduly worn, and
- d) there is no excessive play between stem and threaded bush

If none of the above components needs replacing, lubricate the trapezoid thread and the neck of the bonnet with a suitable lubricant before reassembling the valve

If any parts do need replacing, proceed as follows:

- Undo the hand wheel fastening nut (Pos.20)
- Unscrew the stem (Pos.9) from the bonnet (Pos.2) (unscrew clockwise in the direction of the piston)
- Clamp the piston (Pos.4) in a vice

Attention: Imperatively use soft clamping jaws

- Unscrew the split nut (Pos.11)

Attention: Left thread !

Deinstallation of the threaded bush at KVN 125 – 150

If the bonnet is provided with a threaded bush (Pos.8), proceed as follows:

- Tap the tension pin (Pos.24) out of the bonnet (inwards)
- Clamp the bonnet in the vice unscrew the threaded bush using spindle and hand wheel (see Page 11 Fig. 6)
- Screw the new threaded bush into the bonnet and pin them together *)

**) When renewing actuating parts, we recommend putting in a new spindle and threaded bush at the same time*

- Mount the spindle in the piston after thoroughly lubricating the spindle head **with a suitable lubricant (Metaflux Lubricating Metal Paste 70-85)**
- Mount the spindle into the bonnet and install the hand wheel. Lubricate spindle **with a suitable lubricant (Metaflux Lubricating Metal Paste 70-85)**

Assembling body and bonnet unit

- Screw spindle with piston into bonnet (turn hand wheel counter-clockwise)
- Position bonnet on valve body, mount Belleville washers and screw on nuts
- Now close valve completely and open it again (when it opens, the bonnet with draws into the valve body)
- Tighten nuts
- Close valve completely (turn hand wheel clockwise)
- Tighten bonnet hexagon nuts with torque wrench in diagonal order to specified torque.

For torque specifications, see **Technical Data Sheet Page 12**

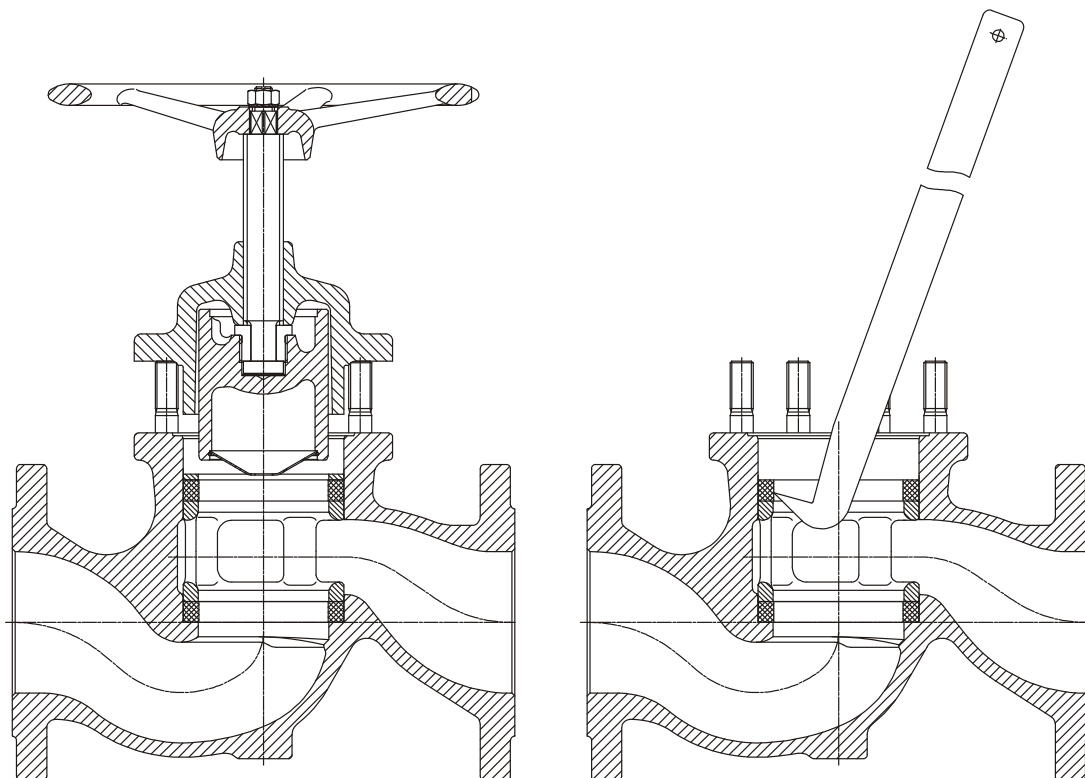

Fig.2

Fig.3

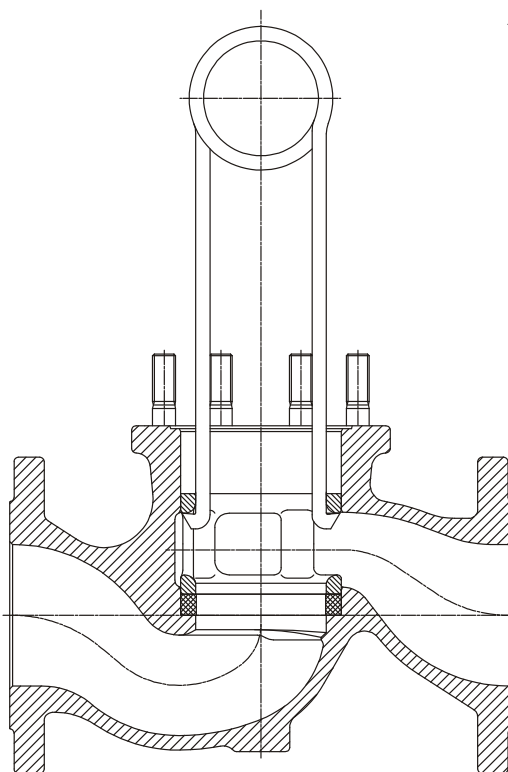

Fig.4

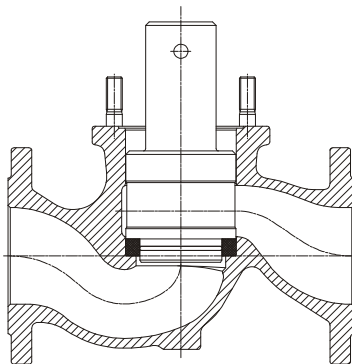

Fig. 5

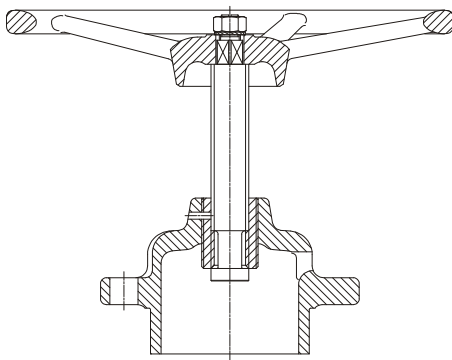

Fig. 6

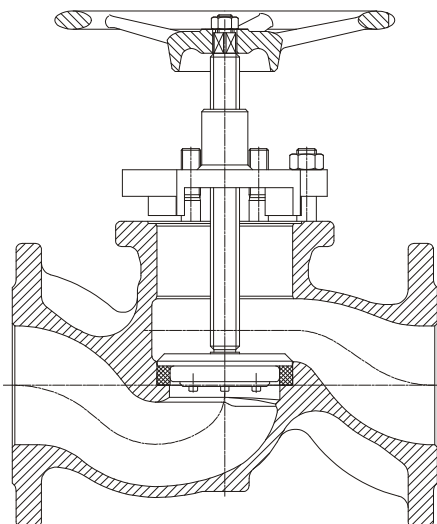

Fig. 7

Tightening torques

connection body-bonnet			
DN	tightening torque (Nm)	stud bolts	piece
65	20	<i>M 16 x 45</i>	4
80	15	<i>M 16 x 45</i>	6
100	20	<i>M 16 x 50</i>	8
125	20	<i>M 20 x 60</i>	6
150	20	<i>M 20 x 60</i>	8

Notes upon Torques:

*The values specified are guide values and apply to lubricated nuts and bolts.
With valves that have been in service a long time and already show wear on the sealing surfaces or, in the case of gaseous process fluid, where leakage is detected under high pressures can be retightened with hexagon nut (Pos.21). The tightening torque can be increased by max. 40 %.*

piston complet

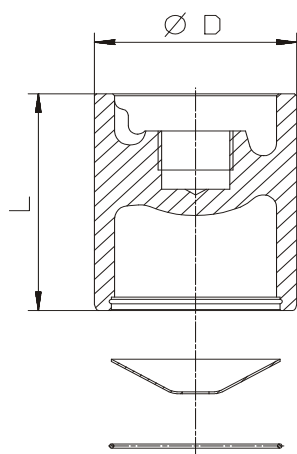

DN	D	L
65	60	76,5
80	70	88
100	90	115
125	110	126
150	130	140

threaded bush

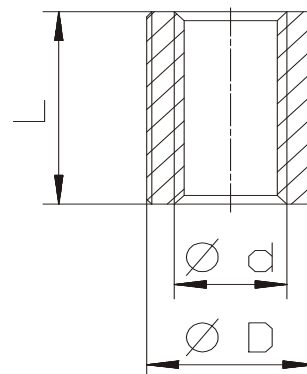

DN	D	d	L
65	M 30 x 1,5	Tr 24 x 5	40
80	M 30 x 1,5	Tr 24 x 5	48
100	M 34 x 1,5	Tr 28 x 5	58
125	R 1 ½ "	Tr 32 x 5	60
150	R 1 ½ "	Tr 32 x 5	60

top and bottom valve ring KX-GT

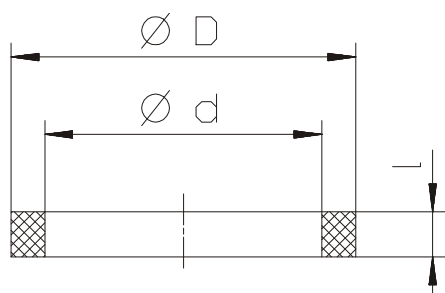

DN	D	d	l
65	82	60	13,3
80	94	70	14,6
100	112	90	14,6
125	135	110	16
150	155	130	17,3

spindle complet

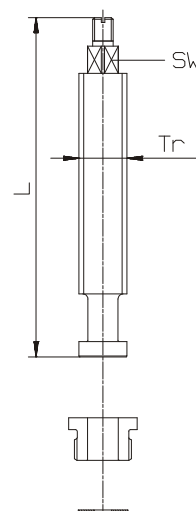

DN	Tr	L	SW
65	24 x 5	152	14
80	24 x 5	167	14
100	28 x 5	200	14
120	32 x 5	227	17
150	32 x 5	239	17