

INSTALLATION / OPERATION / MAINTENANCE INSTRUCTIONS
Magnetic Level Gauge

Under the requirements of the Pressure Equipment Directive (PED 97/23/EC), the Magnetic Level Gauge can not be classified as a pressure safety device. This equipment can only be used for liquid fluid measurement.

1: General

The TC Fluid Control Magnetic level gauge is designed to give an uninterrupted and immediate level indication of most liquids including steam condensate and arduous chemicals. A variety of accessories can be factory or retrofitted including transmitters and various switches with the appropriate approvals.

2: Principle of Operation

The magnetic level gauge is designed so that the liquid being measured is enclosed within a sealed chamber. A float fitted with a permanent omni-directional magnet moves freely inside the chamber and actuates the magnetic wafer within the indicator which is fixed on the outside of the chamber body. As the float raises or falls with the liquid level, each wafer rotates 180° and so presents a contrasting colour. The wafers above the liquid level will show white, whereas the wafers below will show red. The indicator then presents a clearly defined liquid level within the chamber. The wafers can resist accidental disturbance such as vibration due to their edge magnetisation and mutual attraction. Optional red and green wafers are available for steam applications.

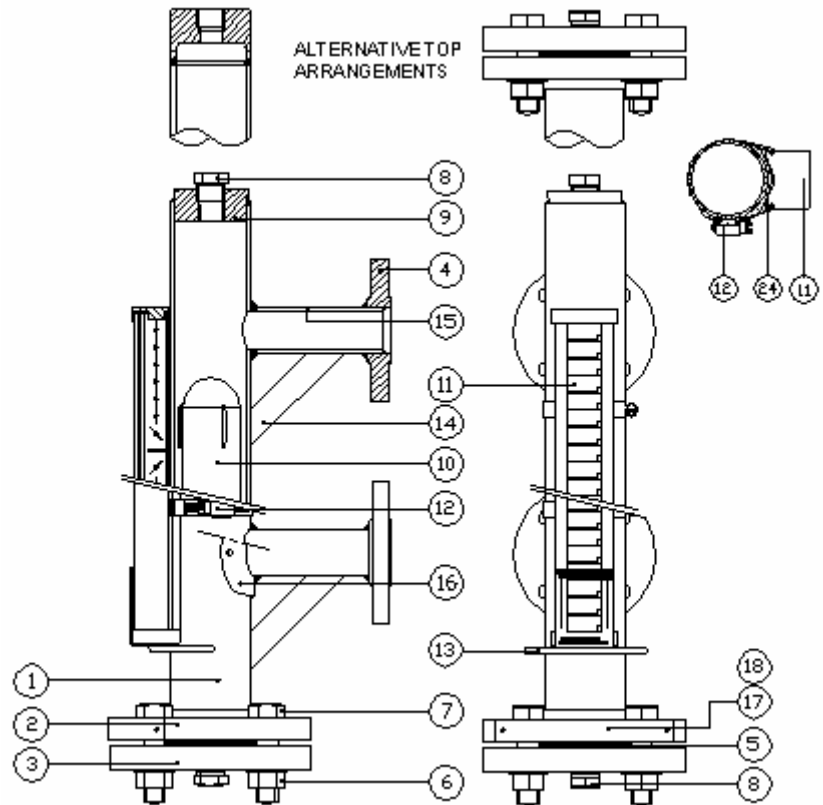

WARNINGS:

- The maximum operating conditions are specified on the tag plate and must not be exceeded.
- Exceeding these limits may lead to a failure of the chamber integrity and possible harm to persons/property.
- The material selection of the gauge system must be suitable/ resistant for the media and environmental conditions.
- Design parameters allow the gauge to be operated up to 450°C. Measures should be in place to avoid contact with this equipment.
- It is the client's responsibility to fit an appropriate pressure relief safety device within the system being monitored.
- The gauge system must not be modified, as this will invalidate the certification.
- Ensure vent and drain plugs are sealed during service.
- Any work carried out on this equipment must be covered by a 'permit to work' procedure.

Commissioning

- Installation and commissioning of the magnetic level gauge should only be carried out by qualified and experienced engineer/ personnel.
- All cabling and electrical connections must be carried out in accordance with the regulations and standards applicable in the country where the equipment is installed and by qualified personnel.
- It is recommended that isolation valves should be fitted between the gauge and the vessel. The selection of the gasket joints and fittings (bolting) to have the required corrosion resistance and rated accordingly.

24	INSULATION
17	LABEL
16	REINFORCEMENT PAD
15	BRANCH NOZZLE TUBE
14	BRANCH SUPPORT
13	INDICATOR SUPPORT
12	INDICATOR CLIP
11	INDICATOR
10	FLOAT
9	END CAP
8	PLUG 1/2", 3/4" NPT/BSP
7	BOLT
6	NUT
5	JOINT
4	VESSEL FLANGE
3	FLANGE
2	BOTTOM FLANGE
1	GAUGE BODY
ITEM	DESCRIPTION

3: Installation of the gauge.

Before mounting the gauge into position, the following points should be taken into account.

- Vessel connections on the vessel/tank must be vertically in line.
- It is not recommended that connections are taken from inlet or discharge lines as excessive surging may occur within the gauge.
- Centre to centre dimensions between vessel connections on the tank and gauge must be within 1.5 mm of each other.
- Ensure connecting pipe work is adequately supported to reduce additional stress due to gauge weight.

Fit the gauge to the vessel/tank using the appropriate rated fixtures and gaskets. Ensure that the gasket material is resistant to the media and its vapour. Make sure that the vessel flange bolting is tightened to the required torque value.

Optional extras such as the transmitter and switches are normally factory fitted onto the chamber. Switches can be adjusted accordingly.

4: Installation of float.

Up-pack the float from its protective case and proceed as follows:

It may be necessary to align the indicator wafers to represent their white face; this can be achieved by running a magnet along the length of the indicator unit. If a float failure warning indication is fitted, the bottom three wafers will show red. (Refer to the appropriate IOM sheets with regards to the setting up procedure required for the switches).

- Remove the bottom flange from the chamber
- Check that the float fits freely into the chamber. If bumper wires are fitted on the float, these can be pushed down to aid clearance. If there is insufficient clearance, consult TC Fluid Control Ltd.
- Check that the specific gravity (S.G.) etched on the float is suitable for the media in question.
- Clean the float of any adhering steel particles and install the float with the cap marked "TOP" uppermost in the chamber.
- Replace the bottom flange and gasket. Bolt flange accordingly to the required torque value.

Recommended Bolt Torque.

Chamber size	Typical Gasket	Bolt size	Rating				
			150	300	600	900	1500
2"	Glass fibre + NBR binder	5/8" UNC	101 Nm 75 lb.f.ft	101 Nm 75 lb.f.ft	101 Nm 75 lb.f.ft		
2 ½ "	Spiral wound 316/graphite	1" UNC				423 Nm 312 lb.f.ft	528 Nm 390 lb.f.ft
3"	Glass fibre + NBR binder	¾ " UNC	126 Nm 93 lb.f.ft	177 Nm 131 lb.f.ft			

Notes.

- Values are based on lubricated ASTM A193 Grade B7 bolts fitted with ASTM A194 Grade 2H nuts (co-efficient of friction =0.12), and are the **minimum** torque required to ascertain a seal. Please note that the final torque required to seal the gasket joint may vary greatly due to the effects of temperature, corrosion, level of lubrication and thread finish.
- For alternative flanging, bolting and gasket configurations, consult TC Fluid Control Limited for advice.
- Bolts should be progressively tightened in a star pattern to ensure even gasket loading. Load should be applied in either 50/100% or 25/50/75/100% of the target torque value, this will depend on the integrity required for the joint.
- The information given in the above table should only be used as a guideline and is not mandatory.

5: Functional Testing of the Gauge.

Before bringing the magnetic level gauge into service, it is advisable to carry out a functional test especially when switches and/or transmitter are fitted.

- Ensure that the gauge system is isolated from the vessel.
- Wire in any switches and/or transmitter as required following the correct electrical procedures.
- The level within the gauge can be imitated by pouring water into the chamber via the top vent.
- Make appropriate checks covering the performance of any ancillaries and indicator operation.
- Open the drain/drain valve and allow the water to run out, thus simulating a falling level.
- Check ancillaries and the indicator unit accordingly.
- Close vent and drain.

Reference:	IOM MLG	Revision:	E
Page 2 of 6		Updated:	18/05/04

6: Bringing into service.

If there are no isolation valves fitted between the level gauge and vessel, then the gauge will automatically be brought into service along with the vessel.

When isolation valve are fitted, the procedure are as follows;

- Allow time for the gauge to reach the operating temperature.
- Ensure vent and drain connections are shut off.
- **Slowly** open the isolation valve fitted to the **upper** vessel connection.
- **Slowly** open the isolation valve fitted to the **lower** vessel connection. This will allow the liquid level to rise in the gauge chamber thereby rotating the wafers to indicate red.

The actual liquid level is shown by the red/white wafer interface.

7: Maintenance.

No maintenance is required other than periodic inspection to ensure that the gauge is free from foreign particles, sediment or scale etc. Freedom of the float movement may be checked by momentarily opening the drain valve if fitted, (depending upon the process, the isolation valve may have to be closed. Follow the procedure 6: Bringing into service). A drop in the indicated level will demonstrate that the float is free.

A damaged or punctured float will sink and this would be indicated by the bottom three wafers changing. In this event the float must be replaced.

8: Removal of the gauge.

- Isolate the gauge from the source of pressure/media by closing the appropriate isolation valves.
- Relieve the gauge of any internal pressure and fluid contents by opening the drain valve. Ensure all safety precautions are in place for safe disposal of the contents. Time must be allowed for the gauge and contents to cool prior to this operation.
Warning: The pressurised level gauge may contain potential hazardous fluids. Wear appropriate protective clothing.
- When the gauge has cooled, isolate and remove any ancillary equipment.
- Dismantle respective vessel connections and remove the gauge.

9: Removal of the float.

- Isolate the gauge from the source of pressure/media by closing the appropriate isolation valves.
- Relieve the gauge of any internal pressure and fluid contents by opening the drain valve. Ensure all safety precautions are in place for safe disposal of the contents. Time must be allowed for the gauge and contents to cool prior to this operation.
- When the gauge has cooled, remove the bottom flange.
- Remove the float.

10: Service Life.

Service life depends upon the combination of pressure/temperature and the media. A majority of the gauges are constructed from stainless steel and should give a long service life due to concept of passive protection. The effects of chemical agents, corrosion and vibration are covered by the requirements of the PED 97/23/EC. Alternative materials can be supplied for certain arduous conditions. Check condition of the float and spring damper system (if fitted) periodically. Generally service life is 10 years unless otherwise specified.

11: High temperature Service.

For gauge operating above 150°C or below 0°C, insulation is fitted between the indicator unit and the gauge body. The level of insulation is dependent upon the temperature. This must be re-fitted whenever the indicator is removed.

12: Spares.

All replacement components must be genuine TC Fluid Control Ltd. spares. When ordering, the TC Fluid Control job number and tag number should be quoted. This information can be found on the nameplate, which is normally fitted to the bottom flange.

Reference:	IOM MLG	Revision:	E
Page 3 of 6		Updated:	18/05/04

13:Gauge subjected to ATEX requirements

The magnetic level gauge is covered by EN 13463-1 for the use of non-electrical equipment for potentially explosive atmospheres as defined by EC directive 94/9/EC.

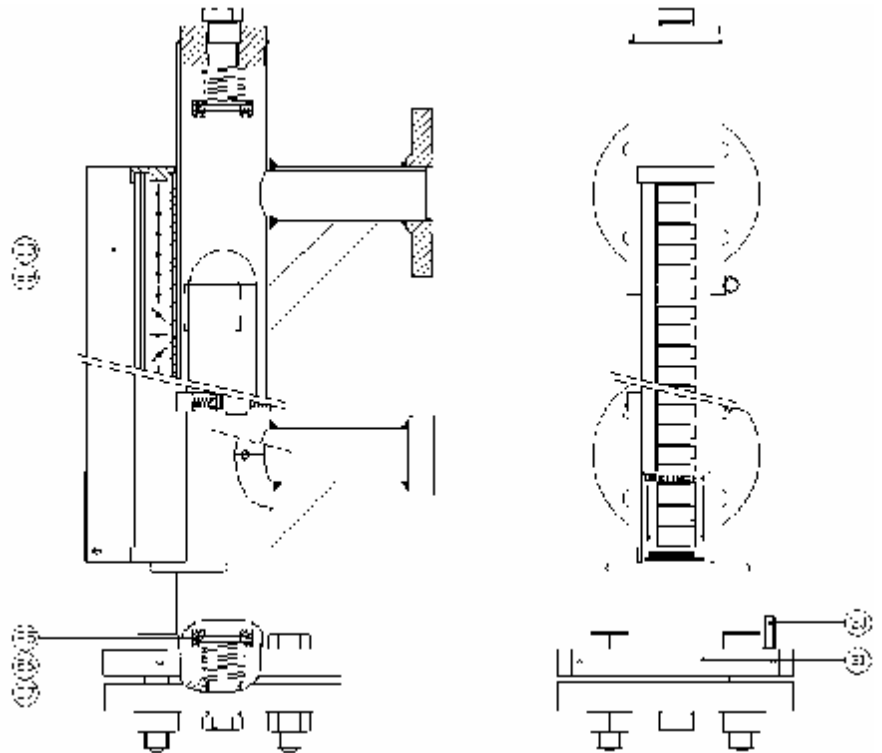
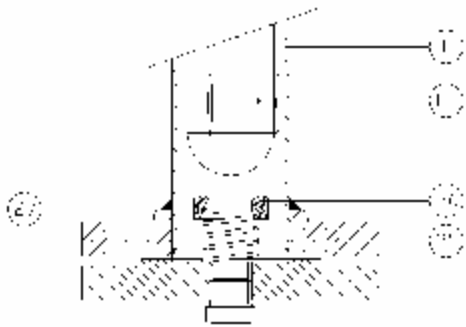

ITEM	DESCRIPTION
1	GAUGE BODY
10	FLOAT
25	S/S SPRING
26	PTFE CAP
27	RING
28	NON FROST BLOCK
29	S/S CLADDING
30	EARTH STUD
31	ATEX LABEL

14: Certification

Category 1 SIRA 04ATEX6126
 Category 1/2 SIRA 04ATEX6126
 Category 2 SIRA 04ATEX133



15: Temperature class

Relationship between 'T' rating Temperature class, Ambient and Process Temperatures.

Temperature Class	Process Temperature	Ambient Temperature
T1	[450°C	-50 °C...+80 °C
T2	[300°C	
T3	[200°C	
T4	[135°C	
T5	[100°C	
T6	[85°C	-50 °C...+60 °C

The operating conditions must not exceed the maximum process temperature shown in the above table for a given 'T' rating.

Conditions for safe use:

- Stainless steel clad non-frost blocks must be earth bonded for category 1 and 2 applications.
- Clean non-frost block vision panel only with a damp cloth.
- Limit the maximum float velocity under surging conditions to 1 m/s by fixture the appropriate flow restrictions.
- For any surging conditions (stainless steel or titanium floats), spring buffer with PTFE cap must be fitted to category I, II and III applications.
- Check periodically the condition of the float and spring assembly. Follow procedures as stated for the removal of the float.
- Maximum process temperature for ATEX categories I, II and III applications when fitted with a spring damping system is limited to 260°C (depending on media).
- For process media's which are subjected to gassing off or surging due to temperature changes, it is recommended to fit insulation around the gauge body.
- No tools that may cause a spark to be used in a potentially explosive atmosphere unless covered by a 'Permit to Work' system.
- For electrical equipment such as transmitters or switches, refer to the respective IOM.
- Use stainless steel clad display units for category I applications.
- Maximum process temperature for a stainless steel float is 450°C and a titanium float is 315°C

Reference: Page 4 of 6	IOM MLG	Revision: Updated:	E 18/05/04
---------------------------	---------	-----------------------	---------------

TROUBLE SHOOTING GUIDE

Problem	Possible cause	Action/ rectification procedure
Float fails to raise or fall	Isolation valves closed.	Open slowly as appropriate as per procedure 6.
	Blockage in the connecting pipe-work.	Clean blockage as required
	Float sticking in chamber.	Remove the float as per procedure 9. Check clearance between the bumper wires and the chamber bore. If insufficient clearance, push the bumpers down flat to aid clearance.
		Check that there is no sediment, scale or solidification of the media built up inside the chamber.
	Float damaged.	Check for puncture and ingress of media into float.
Incorrect S.G. float used.	Check that the S.G. range etched on the float matches the corresponding media S.G.	
Incorrect level is displayed.	The S.G. of the float differs to that of the media.	Check that the S.G. range etched on the float matches the corresponding media S.G.
	The float has been incorrectly installed upside down	Remove the float and replace with the top end uppermost in the chamber.
Banks or clusters of wafers are not turning.	The media has surged thus causing the float within the chamber to travel at abnormally high speed thus 'missing' the magnetic field of the wafers.	Reduce surging by fitting orifice plates or throttling the vessel valves accordingly.
	Damaged float magnet.	Replace with new float. Carry out functional test as per procedure 5.
Inverse wafer operation.	Indicator upside down.	Check orientation of indicator. Note that 'top' is stamped on end cap of indicator.
Wafers in the indicator have discoloured.	Maximum temperature on the gauge tag plate has been exceeded.	Heat shield/s are required. If already fitted, then the insulation specification needs to be increased. Replace indicator if required.
	Heat shields have been removed and not replaced	Refit insulation between display and chamber. Replace indicator if required.

All information and recommendations contained in this publication are to the best of our knowledge correct. Since conditions of use are beyond our control, user must satisfy themselves that the product is suitable for the intended processes and uses. No warranty is given or implied in respect of information or recommendations or that any use of products will not infringe rights belonging to other parties. In any event or occurrence our liability is limited to our invoice value of the goods delivered by us to you. We reserve the right to change product designs and properties without notice.

Reference:	IOM MLG	Revision:	E
Page 5 of 6		Updated:	18/05/04

Data sheet
ATEX 94/9/EC for non electrical equipment EN 13463-1:2001

Parameter	Equipment Category 1	Equipment Category 2	Equipment Category 3
Process parameters			
Equipment group	II	II	II
Category	1	2	3
Level of protection	Very High	High	Normal
Zones Gas vapour mist	0	1	2
Maximum temperature	450°C Note: maximum temperature also determined by 'T' rating, materials and any ancillaries fitted.	450°C Note: maximum temperature also determined by 'T' rating, materials and any ancillaries fitted.	450°C Note: maximum temperature also determined by 'T' rating, materials and any ancillaries fitted.
Minimum temperature	-50°C	-50°C	-50°C
Label details			
Equipment Marking	II 1 G c T1...T6	II 2 G c T1...T6	II 3 G c T1...T6
CE marked	Yes	Yes	Yes
Notified body Number	1180	No	No
ATEX Number	SIRA 04ATEX 6126	SIRA 04ATEX T133	No
Indicator details			
Display unit	Stainless steel clad	Aluminium Optional: Stainless steel clad	Aluminium
Indicator label	Stainless steel	Aluminium Optional: Stainless steel	Aluminium
Non Frost block stainless steel side cladding	Yes To be earth bonded	Yes To be earth bonded	No
Floats			
Use of titanium floats	Must be fitted with spring damping	Must be fitted with spring damping	Yes
Use of stainless steel floats	Yes	Yes	Yes
Use of plastic floats	No	No	No
Spring damping system	If surging (float velocity) exceeds 1 m/s. Note: Maximum process temperature 260°C	If surging (float velocity) exceeds 1 m/s. Note: Maximum process temperature 260°C	If surging (float velocity) exceeds 1 m/s. Note: Maximum process temperature 260°C
Earth stud	Required if Non-frost block are fitted	Required if Non-frost block are fitted	As requested
Chamber			
Chamber Material	Austenitic stainless steel, super austenitic stainless steel and nickel based alloys.	Austenitic stainless steel, super austenitic stainless steel and nickel based alloys.	Austenitic stainless steel, super austenitic stainless steel and nickel based alloys. Titanium Grade 2.
Vessel Flange Material	Carbon steel, duplex, austenitic stainless steel, super austenitic stainless steel and nickel based alloys.	Carbon steel, duplex, austenitic stainless steel, super austenitic stainless steel and nickel based alloys.	Carbon steel, duplex, austenitic stainless steel, super austenitic stainless steel and nickel based alloys.
Bottom chamber Flange Material	Carbon steel, duplex flanges, a spring damper must be fitted. Austenitic stainless steel, super austenitic stainless steel and nickel based alloys. Note: If float velocity exceeds 1 m/s a spring damper must be fitted	Carbon steel, duplex, flanges, a spring damper must be fitted. Austenitic stainless steel, super austenitic stainless steel and nickel based alloys. Note: If float velocity exceeds 1 m/s a spring damper must be fitted	Carbon steel, duplex, austenitic stainless steel, super austenitic stainless steel and nickel based alloys flanges. Note: If float velocity exceeds 1 m/s a spring damper must be fitted.
Documentation			
Declaration of conformity	Yes	Yes	Yes
IOM	Yes	Yes	Yes

Notes:

- 1) For hydrogen service a titanium float **must not** be used.
- 2) For saturated steam service only, the environment within the gauge will be non-hazardous regardless of the zone outside, a non-cushioned spring assembly can be fitted. (The maximum temperature is determined by 'T' rating, the material used and any ancillaries fitted).

Reference:	IOM MLG	Revision:	E
Page 6 of 6		Updated:	18/05/04