



INSTALLATION, OPERATION AND MAINTENANCE MANUAL

SAFETY RELIEF VALVES

Revision: 30 June 2004



TABLE OF CONTENTS

1. General
2. Description
3. Installation of safety and safety relief valves
4. Valve adjustments

1. General

This manual is a guidance for the maintenance and installation of TOSACA Safety relief valves. Please read these instructions carefully.

It is recommended that all TOSACA instructions be read prior to any operation of this equipment.

This safety relief valves is designed to protect equipment from overpressure. The valve should be handled with care.

Safety relief valves should be inspected regularly. A visual inspection is recommended at one month intervals while in service.

Cycling the valve at least every ten months is considered to be good practice to verify operation.

TOSACA recommends that all valves be placed on a regular maintenance schedule every two or three year depending of fluid, temperature or set pressure.

The safety relief valves are elements of precision, it must be to operate with extreme care.

The valves are supplied set at the required pressure and sealed.

TOSACA accepts no responsibility for valves which have been reset by unauthorised persons.

All warranties are void if the seal is broken.

The noted manufacturer's standard lubricants should be used only if compatible with process fluid and application.

Specific design details described in this document are subject to change without notice.

If you need assistance contact with TOSACA technical department vstosaca@tosaca.com or www.tosaca.com

2. DESCRIPTION

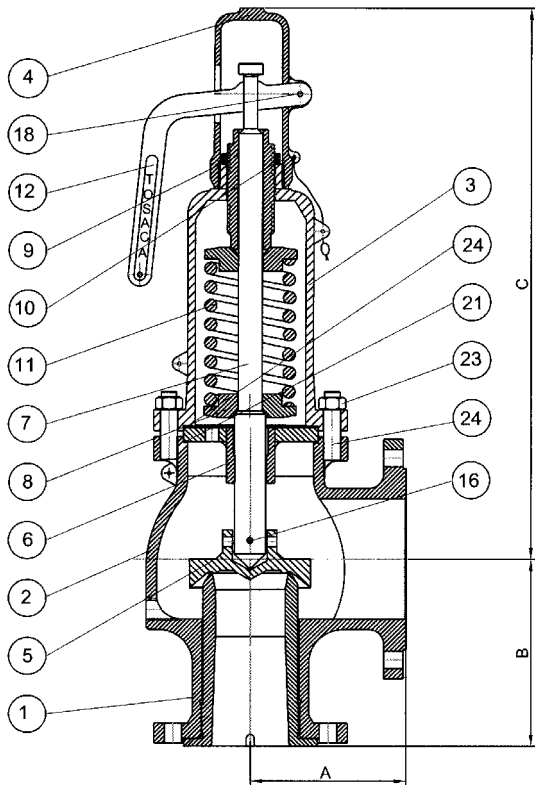

Item	Description
1	Nozzle
2	Body
3	Bonnet
4	Cap
5	Disc
6	Guide
7	Push road
8	Spring button
9	Adjusting screw
10	Tensor nut
11	Spring
12	Lever
13	.
14	Elastic pin
15	.
16	.
17	Release nut
18	Spindle
19	.
20	Gasket
21	Gasket

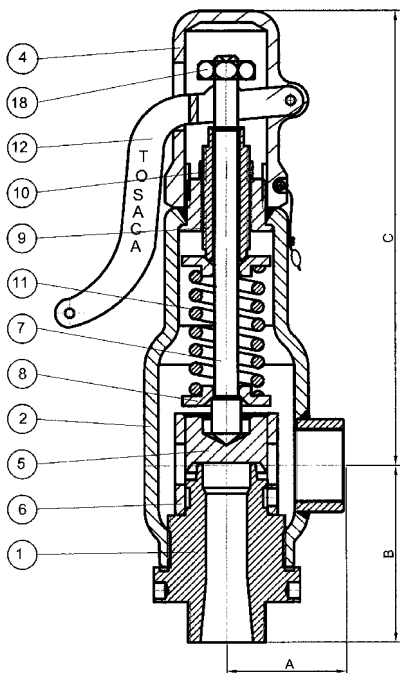

The TOSACA safety relief valves are a direct spring-loaded suitable for gas, liquid and steam service. The seat can be meta-metal, PTFE or viton.

Blowdown up to approx 10%

Backpressure 10%. In some type of valves in liquids can be 20%.

The allowable tolerances or limits as applicable on the operating characteristics are as follows:

- a) Set pressure: $\pm 3\%$ of set pressure or $\pm 0,15$ bar whichever is the greater;
- b) Lift: not lower than the value specified by the manufacturer,
- c) Overpressure: the value stated by the TOSACA but not exceeding 10% of set pressure or 0,1 bar whichever is greater;
- d) Blowdown: not greater than the value stated by the TOSACA, but within the following limits:

Compressible fluids: minimum 2,0% maximum 15% or 0,3 bar, whichever is greater.

Incompressible fluids: minimum: 2,5 % maximum: 20% or 0,6 bar, whichever is greater.

3. INSTALLATION OF SAFETY AND SAFETY RELIEF VALVES

Packing materials. All packing materials should be removed from the valve connections before to installation (plastics caps and lever wires).

Set Pressure. Check that the set pressure on the nameplate is as required.

Back pressure. Check the nameplate to determine if the valve was already set with a correction for backpressure. Verify the maximum value of back pressure and/or consult to TOSACA.

Lever. Do not use the lifting lever to hoist the valve during installation.

Test gag. Remove test gag before to test set pressure.

Spindle vertical. Spring loaded safety and safety relief valves normally should be installed in the upright position with the spindle vertical. Where space or piping configuration preclude such an installation, the valve may be installed in other than the vertical position provided that:

- (a) The valve design is satisfactory for such position;
- (b) The media is such that material will not accumulate at the inlet of the valve; and
- (c) Drainage of the discharge side of the valve body and discharge piping is adequate.

System cleansing. In the new installation are fully flushed and all debris removed before to installing the safety relief valve since damages can be caused to valve seats resulting in subsequent leakage.

Discharge lines. Discharge lines from safety relief valves shall be at least the same size as the valve outlet and as short and direct as possible. The valve body drain and vent holes must not be plugged. Never reduce the inlet or outlet pipe connections to the safety relief valve.

Adequately supported discharge piping relieves stress on the safety relief valves.

Teflon. The use of Teflon impregnated pipe compound and Teflon tape on pipe threads provides lubricity which can lead to overtightening and breakage. Do not overtighten. Failure to follow these instructions could result in property damage and/or moderate personal injury.

Painting. If the safety relief valves are to be painted , care must be taken to protect the lever, open bonnet and plate.

4. VALVE ADJUSTMENTS

If the set pressure is changed more than 5% from the nameplate set pressure, the spring may also have to be changed. Consult to Tosaca to soft repair kit.

4.1 Disassembly

4.1.1. Cut the lockwire.

4.1.2. The spring adjustment screw on bonnet in most of the way. Increase to desired level and back out screw until valve pops. Lock screw with jam nut and retest. Readjust as required.

4.2 Assembly

4.2.1 Assemble in reverse order of disassembly. Make sure the nozzle is fully and evenly seated in guide.

