

SINGLE SEAT TWO WAY CONTROL VALVES

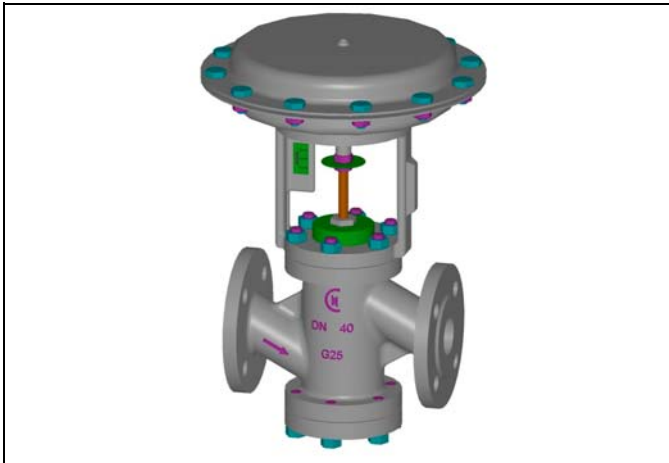

TYPE 5000 AD

Normally open – air closes

Face-to-face ASME / ANSI B16.10

DESCRIPTION

The "UNIWORLD" series type 5000 AD are equipped with "straight-through" pattern bodies having ANSI face-to-face dimensions and EN – ANSI – JIS flanges.

Modulating plug suitable for control of virtually all line media.

Compact construction assembled with multisprings pneumatic actuator having 3-15 psi ...6-30 psi standard control signals.

On request can be equipped with a pneumatic or electro-pneumatic pilot positioner.

SIZES : from DN 15 to DN 200

BODY CONNECTIONS : flanged EN 1092-1 PN16 PN40
flanged ANSI B 16.5 150 RF 300 RF
flanged JIS B2220 10K 20K

MATERIALS OF BODY GROUP (1) :

- **Cast iron EN-GJL-250 UNI EN 1561 PN 16 ANSI 150 JIS 10**
AISI 316 st. st. trim - C40 nickel plated steel bonnet
- **Carbon steel ASTM A216 WCB PN16/40 ANSI 150/300 JIS10/20**
AISI 316 st. st. trim - C40 nickel plated steel bonnet
- **Stainless steel AISI 316 CF8M PN16/40 ANSI 150/300 JIS10/20**
AISI 316 st. st. trim - AISI 316 st. st. bonnet

PLUG :

- **EQP** (DN15-50 & DN125-200) **EQV** (DN65-100) = equal % class IV°
- **PL** (DN15-50 & DN125-200) **LV** (DN65-100) = linear class IV°
- **PT** (DN15-50 & DN125-200) **VPT** (DN65-100) = quick lift class IV°

BONNET (2) :

- Standard : -5 to +200 °C
- Finned : > 200 °C
- Extended : below -5 °C
- Bellows sealed : for thermal oil or hazardous media with (PN 16 - 25 - 40) standard safety gland arrangement

GLAND ARRANGEMENT (PACKING) (3) with safety "0-rings" :

- PTFE 100% for temperatures ≤150 °C
- PTFE 85% + GRAPHITE 15% for temperatures ≤ 200 °C
- PURE GRAPHITE 100% for temperatures from 200° to 400 °C to be used with finned bonnet

CV = american unit (flowrate in USGPM with 1 psi of differential pressure)

TECHNICAL CHARACTERISTICS OF PNEUMATIC ACTUATOR :

- Actuator : diaphragm type
- Control signals : 3-15 psi ... 6-30 psi
- Max air supply pressure : 35 psi (2,5 bar)
- Ambient temperature : -20 ... +70 °C
- Actuator casings material : Fe P11 carbon steel
- Diaphragm material : EPDM 70
- Yoke material : GGG 50 Spheroidal cast iron
- Pneumatic connections : ISO 7 Rp – 1/8"

MAX WORKING CONDITIONS :

- Max inlet pressure and temperature : see leaflet n° 101/VP
- Valve sizing : see leaflet n° 100/VP
- Rangeability : see leaflet n° GRAFICI/I

ON REQUEST :

- PTFE/GR soft seal ≤190°C class VI°
- PTFE soft seal ≤150°C class VI°
- Lapping on seat and plug class V°
- Stellite (degree 6°) on seat and plug and guide bush
- Reduced bore (see below table)
- Pneumatic pilot positioner 3-15 psi...3-9 psi...9-15 psi
- Electro-pneumatic pilot positioner 4-20 mA...4-12 mA...12-20 mA
- Air filter regulator
- Proximity limit switches
- 3-way solenoid valve
- Lubrificator on finned bonnet for temperatures ≥ 250 °C
- Top-work manual handwheel

Kv = metric unit (flowrate in m3/h with 1 bar of differential pressure)

PLUG	Full bore																						
	DN15 Ø 1/2"	DN 20 Ø 3/4"	DN25 Ø 1"	DN32 Ø 1.1/4"	DN40 Ø 1.1/2"	DN50 Ø 2"	DN65 Ø 2.1/2"	DN80 Ø 3"	DN100 Ø 4"	DN125 Ø 5"	DN150 Ø 6"	DN200 Ø 8"											
EQP	CV	3.4	6.6	10.8	17	23.8	50	70.2	87.9	118.5	236	322	612										
	KV	2.9	5.7	9.3	14.7	20.5	43	60.5	75.2	102.1	203	278	528										
PL	CV	3.4	6.6	11.2	17.6	23.9	51.2	72.7	89.3	123.8	299	352	666										
	KV	2.9	5.7	9.6	15.2	20.6	44	62.7	77	106.7	258	304	574										
PT	CV	3.4	6.6	12.1	19	24	52.7	107.3	129.3	175.4	354	517	929										
	KV	2.9	5.7	10.4	16.4	20.7	45.3	92.5	111.5	151.2	305	445	800										
Reduced bore *	•	•	1/2"	1/2"	3/4"	3/4"	1"	1"	1.1/4"	1.1/4"	1.1/2"	1.1/2"	2"	2"	2.1/2"	2.1/2"	3"	3"	4"	4"	5"	5"	6"
• DN 15-20	MFP 1/8"	MFP 3/16"	MFP 1/4"	MFP 3/8"	MFS1SG 1/4"	MFS2SG 1/4"	MFS1SG 3/8"	MFS2SG 3/8"															
CV	0.26	0.71	1.28	2.62	0.65	1.21	1.22	2.25															
KV	0.22	0.61	1.10	2.26	0.56	1.04	1.05	1.94															

MFP = Linear..MFS = Equal percentage

* CV and KV values are referred to the selected diameter and plug type (EQP/EQV-PL/LV only)

CONFLOW s.p.a.

COMPANY
WITH QUALITY SYSTEM
CERTIFIED BY DNV
ISO 9001

Via Lecco, 69/71
20041 AGRATE BRIANZA (MI)
Tel. 039/651.705 - 650.397
Fax 039/654.018

Maximum permissible pressure drops in Kg/cm² (fluid opens) Strokes in mm – Signals in psi

Actuator type	Signal psi	DN15	DN20	DN25	DN32	DN40	DN50	DN65	DN80	DN100	DN125	DN150	DN200
		Stroke 11	Stroke 11	Stroke 11	Stroke 19	Stroke 19	Stroke 19	Stroke 28	Stroke 28	Stroke 28	Stroke 50	Stroke 50	Stroke 50
T200	3-15 psi	12	8	5	3	-	-	-	-	-	-	-	-
	6-30 psi	52	32	18	11	-	-	-	-	-	-	-	-
T250	3-15 psi	27	17	9	6	4	2.4	-	-	-	-	-	-
	6-30 psi	113	69	39	25	17	10	-	-	-	-	-	-
T310	3-15 psi	-	-	15.5	10	7	3.5	2.5	1.7	0.9	-	-	-
	6-30 psi	-	-	63	41	28	16	10	7	4	-	-	-
T400	3-15 psi	-	-	-	14.5	10.5	5.5	3.8	2.5	1.4	0.9	0.65	0.35
	6-30 psi	-	-	-	60	42	24	15	10.5	5.9	3.8	2.6	1.5
T500	3-15 psi	-	-	-	24.5	17.5	9.5	6.2	4.2	2.4	1.55	1.1	0.95
	6-30 psi	-	-	-	101	70	40	25.3	17.5	9.9	6.4	4.5	2.5

T200 DN15-20 Microflow	Signal	MFP 1/8 "	MFP 3/16 "	MFP 1/4 "	MFP 3/8 "	MFS1SG 1/4 "	MFS2SG 1/4 "	MFS1SG 3/8 "	MFS2SG 3/8 "
	3-15 psi	200	90	50	30	50	50	30	30
	6-30 psi	1080	470	270	130	270	270	130	130

1. The values given are referred to the force of actuator and they can be used within the limit of the body rating
2. The actuator DELTA-PI (PRESSURE DROPS with CLOSED VALVE) given in the column 3-15 psi are obtained with a thrust of 18 psi
3. The actuator DELTA-PI (PRESSURE DROPS with CLOSED VALVE) given in the column 6-30 psi are obtained with a thrust of 30 psi
4. The actuator DELTA-PI given in the column 6-30 psi are also valid for ON-OFF service with air supply at 30/35 psi

COMPONENTS LIST AND MATERIALS

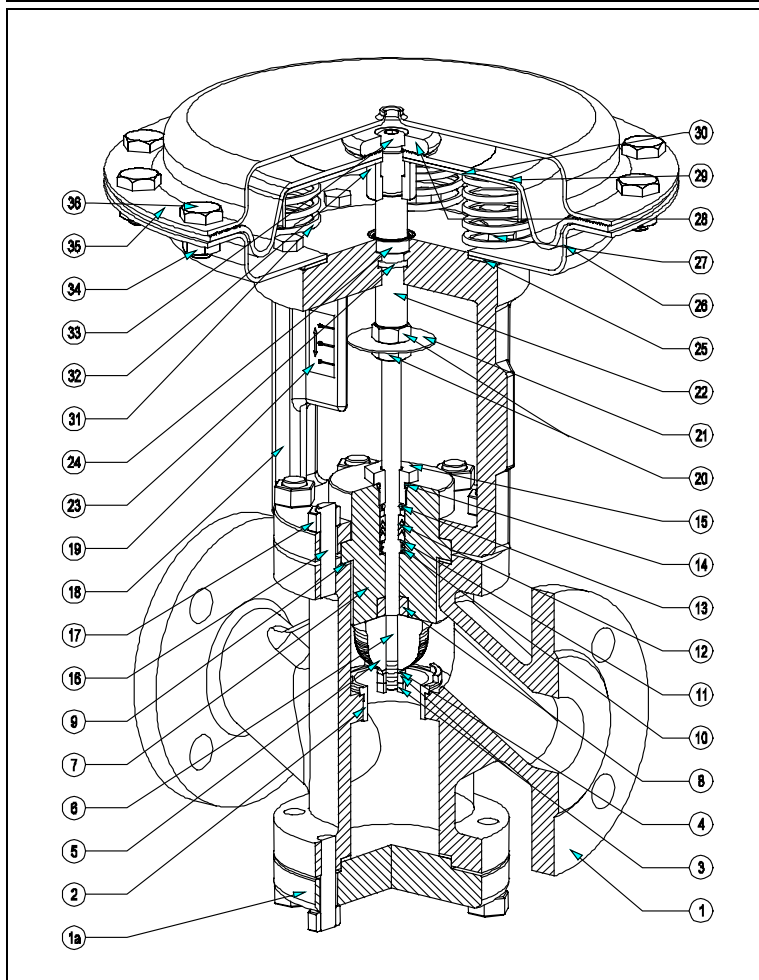

COMPONENTS LIST

1. Body
- 1a. Bottom flange
2. Seat
3. Plug locknuts
4. Spring washer
5. Plug
6. Stem
7. Bonnet
8. Guide bush
9. Body gasket
10. Packing spring
11. Packing washer
12. Packing rings
13. Internal "O" ring
14. External "O" ring
15. Packing adjusting nut
16. Stud-bolts
17. Body locknuts
18. Yoke
19. Travel indicator plate
20. Position indicator locknuts
21. Position indicator
22. Diaphragm rod
23. "O" ring
24. Airtight
25. Yoke gasket
26. Lower diaphragm casing
27. Lower diaphragm casing internal bolts
28. Diaphragm spacer
29. Diaphragm
30. Diaphragm plate
31. Springs
32. Diaphragm bush
33. Diaphragm locknut
34. Diaphragm casing bolts
35. Upper diaphragm casing
36. Diaphragm casing locknuts

MATERIALS

1. See note (1) at page 1
- 1a. C40 carbon steel
2. AISI 316 stainless steel
3. AISI 304 stainless steel
4. AISI 304 stainless steel
5. AISI 316 stainless steel
6. AISI 316 stainless steel
7. See note (1)-(2) at page 1
8. AISI 304 stainless steel
9. Europil WS 3640 or PTFE
10. AISI 302 stainless steel
11. AISI 304 stainless steel
12. See note (3) at page 1
13. Viton FPM 70
14. Viton FPM 70
15. AISI 303 stainless steel
16. Galvanized steel
17. DIN 934 galvanized steel
18. GGG50 spheroidal c. iron
19. Polycarbonate
20. DIN 936 galvanized steel
21. Aluminium
22. AISI 303 stainless steel
23. NBR
24. NBR
25. Cork – rubber
26. P11 steel
27. DIN 933 galvanized steel
28. Galvanized steel
29. EPDM 70
30. P01 steel
31. C98 UNI 3823
32. AISI 303 stainless steel
33. ISO 7380 galvanized steel
34. DIN 934 galvanized steel
35. P11 steel
36. DIN 933 galvanized steel

DIMENSIONS in mm.

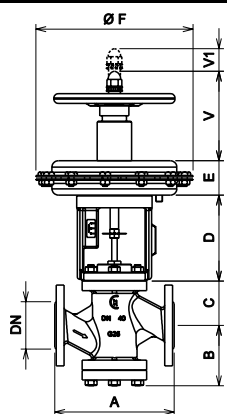

DN	Ø	A(1)	A(2)	B	C – Bonnet			D	V	V1
					Std	Finned	Bellows			
15	1/2 "	184	190	67	49	181	181	147	166	11
20	3/4 "	184	194	67	58	190	190	147	166	11
25	1 "	184	197	90	68	200	200	147	166	11
32	1.1/4 "	200	212	92	70	202	202	147	166	19
40	1.1/2 "	222	235	108	82	214	214	160	166	19
50	2 "	254	267	108	86	218	218	160	166	19
65	2.1/2 "	276	292	148	111	309	309	160	166	28
80	3 "	298	317	148	135	333	333	160	166	28
100	4 "	352	368	176	160	363	363	204	166	28
125	5 "	403	425	223	252	435	435	213	166	50
150	6 "	450	473	229	258	442	442	213	166	50
200	8 "	543	568	254	283	465	465	213	166	50

Actuator	E	Ø F
200	70	210
250	70	292
310	95	336
400	119	408
500	119	520

A(1) cast iron = PN16 – ANSI150 – JIS10K

A(2) carbon and st. steel = PN16 – PN40 – ANSI150 – ANSI300 – JIS10K – JIS20K

Specifications given are only indicative and not binding for the manufacturer who reserve the right to carry-out any modification deemed necessary without prior notice

SINGLE SEAT TWO WAY CONTROL VALVES

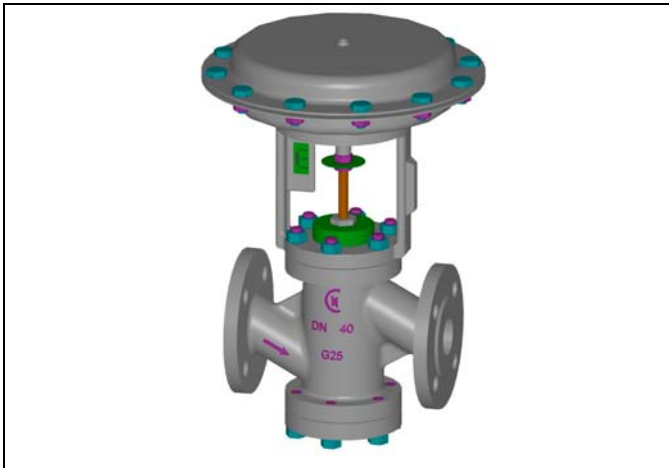

TYPE 5000 AR

Normally closed – air opens

Face-to-face ASME / ANSI B16.10

DESCRIPTION

The “UNIWORLD” series type 5000 AR are equipped with “straight-through” pattern bodies having ANSI face-to-face dimensions and EN – ANSI – JIS flanges.

Modulating plug suitable for control of virtually all line media.

Compact construction assembled with multisprings pneumatic actuator having 3-15 psi ... 6-18 psi ... 6-30 psi standard control signals.

On request can be equipped with a pneumatic or electro-pneumatic pilot positioner.

SIZES : from DN 15 to DN 200

BODY CONNECTIONS : flanged EN 1092-1 PN16 PN40
flanged ANSI B 16.5 150 RF 300 RF
flanged JIS B2220 10K 20K

MATERIALS OF BODY GROUP (1) :

- **Cast iron EN-GJL-250 UNI EN 1561 PN 16 ANSI 150 JIS 10**
AISI 316 st. st. trim - C40 nickel plated steel bonnet
- **Carbon steel ASTM A216 WCB PN16/40 ANSI 150/300 JIS10/20**
AISI 316 st. st. trim - C40 nickel plated steel bonnet
- **Stainless steel AISI 316 CF8M PN16/40 ANSI 150/300 JIS10/20**
AISI 316 st. st. trim - AISI 316 st. st. bonnet

PLUG :

- **EQP** (DN15-50 & DN125-200) **EQV** (DN65-100) = equal % class IV°
- **PL** (DN15-50 & DN125-200) **LV** (DN65-100) = linear class IV°
- **PT** (DN15-50 & DN125-200) **VPT** (DN65-100) = quick lift class IV°

BONNET (2) :

- Standard : -5 to +200 °C
- Finned : > 200 °C
- Extended : below -5 °C
- Bellows sealed : for thermal oil or hazardous media with (PN 16 - 25 - 40) standard safety gland arrangement

GLAND ARRANGEMENT (PACKING) (3) with safety “0-rings” :

- PTFE 100% for temperatures ≤150 °C
- PTFE 85% + GRAPHITE 15% for temperatures ≤ 200 °C
- PURE GRAPHITE 100% for temperatures from 200° to 400 °C to be used with finned bonnet

CV = american unit (flowrate in USGPM with 1 psi of differential pressure)

TECHNICAL CHARACTERISTICS OF PNEUMATIC ACTUATOR :

- Actuator : diaphragm type
- Control signals : 3-15 psi ... 6-18 psi ... 6-30 psi
- Max air supply pressure : 35 psi (2,5 bar)
- Ambient temperature : -20 ... +70 °C
- Actuator casings material : Fe P11 carbon steel
- Diaphragm material : EPDM 70
- Yoke material : GGG 50 Spheroidal cast iron
- Pneumatic connections : ISO 7 Rp – 1/8”

MAX WORKING CONDITIONS :

- Max inlet pressure and temperature : see leaflet n° 101/VP
- Valve sizing : see leaflet n° 100/VP
- Rangeability : see leaflet n° GRAFICI/I

ON REQUEST :

- PTFE/GR soft seal ≤190°C class VI°
- PTFE soft seal ≤150°C class VI°
- Lapping on seat and plug class V°
- Stellite (degree 6°) on seat and plug and guide bush
- Reduced bore (see below table)
- Pneumatic pilot positioner 3-15 psi...3-9 psi...9-15 psi
- Electro-pneumatic pilot positioner 4-20 mA...4-12 mA...12-20 mA
- Air filter regulator
- Proximity limit switches
- 3-way solenoid valve
- Lubrificator on finned bonnet for temperatures ≥ 250 °C
- Top-work manual handwheel

Kv = metric unit (flowrate in m3/h with 1 bar of differential pressure)

PLUG	Full bore	DN15	DN 20	DN25	DN32	DN40	DN50	DN65	DN80	DN100	DN125	DN150	DN200											
		Ø 1/2"	Ø 3/4"	Ø 1"	Ø 1.1/4"	Ø 1.1/2"	Ø 2"	Ø 2.1/2"	Ø 3"	Ø 4"	Ø 5"	Ø 6"	Ø 8"											
EQP	CV	3.4	6.6	10.8	17	23.8	50	70.2	87.9	118.5	236	322	612											
	KV	2.9	5.7	9.3	14.7	20.5	43	60.5	75.2	102.1	203	278	528											
PL	CV	3.4	6.6	11.2	17.6	23.09	51.2	72.7	89.3	123.8	299	352	666											
	KV	2.9	5.7	9.6	15.2	20.6	44	62.7	77	106.7	258	304	574											
PT	CV	3.4	6.6	12.1	19	24	52.7	107.3	129.3	175.4	354	517	929											
	KV	2.9	5.7	10.4	16.4	20.7	45.3	92.5	111.5	151.2	305	445	800											
Reduced bore *		•	•	1/2"	1/2"	3/4"	3/4"	1"	1"	1.1/4"	1.1/4"	1.1/2"	1.1/2"	2"	2"	2.1/2"	2.1/2"	3"	3"	4"	4"	5"	5"	6"
• DN 15-20		MFP 1/8"	MFP 3/16"	MFP 1/4"	MFP 3/8"	MFS1SG 1/4"	MFS2SG 1/4"	MFS1SG 3/8"	MFS2SG 3/8"															
CV		0.26	0.71	1.28	2.62	0.65	1.21	1.22	2.25															
KV		0.22	0.61	1.10	2.26	0.56	1.04	1.05	1.94															

MFP = Linear..MFS = Equal percentage

* CV and KV values are referred to the selected diameter and plug type (EQP/EQV-PL/LV only)

Maximum permissible pressure drops in Kg/cm2 (fluid opens)

Strokes in mm

Signals in psi

Actuator type	Signal psi	DN15	DN20	DN25	DN32	DN40	DN50	DN65	DN80	DN100	DN125	DN150	DN200
		Stroke 11	Stroke 11	Stroke 11	Stroke 19	Stroke 19	Stroke 19	Stroke 28	Stroke 28	Stroke 28	Stroke 50	Stroke 50	Stroke 50
T200	3-15 psi	12	8	5	3	-	-	-	-	-	-	-	-
	6-18 psi	25	16	9	6	-	-	-	-	-	-	-	-
	6-30 psi	65	40	22	11	-	-	-	-	-	-	-	-
T250	3-15 psi	27	17	9	6	4	2.4	-	-	-	-	-	-
	6-18 psi	55	34	19	12	8	3	-	-	-	-	-	-
	6-30 psi	110	68	38	20	14.5	7	-	-	-	-	-	-
T310	3-15 psi	-	-	15.5	10	7	3.5	2.5	1.7	0.9	-	-	-
	6-18 psi	-	-	31	20	14	7	4.2	2.8	1.3	-	-	-
	6-30 psi	-	-	62	30	21	12	6.5	4.7	2.6	-	-	-
T400	3-15 psi	-	-	-	14.5	10.5	5	3.8	2.5	1.4	0.9	0.65	0.35
	6-18 psi	-	-	-	29.5	20.5	12	6.7	4	2.8	1.85	1.3	1.05
	6-30 psi	-	-	-	45	31.5	18	16	11	6.3	4.5	3.2	1.8
T500	3-15 psi	-	-	-	24.5	17.5	9.5	5.5	4.2	2.4	1.55	1.1	0.95
	6-18 psi	-	-	-	49	34.5	19.5	12.2	7	4.9	3.1	2.2	1.25
	6-30 psi	-	-	-	75	52.5	30.3	26	16	10.5	5.5	4	2.2
T200 DN15-20 Microflow	Signal	MFP 1/8 "	MFP 3/16 "	MFP 1/4 "	MFP 3/8 "	MFS1SG 1/4 "	MFS2SG 1/4 "	MFS1SG 3/8 "	MFS2SG 3/8 "				
	3-15 psi	200	90	50	30	50	50	30	30				
	6-18 psi	400	180	100	60	100	100	60	60				
	6-30 psi	1300	580	340	160	340	340	160	160				

1. The values given are referred to the force of actuator and they can be used within the limit of the body rating
 2. The actuator DELTA-PI (PRESSURE DROPS with CLOSED VALVE) are obtained without a residual thrust of air into the actuator
 3. The actuator DELTA-PI given in the column 6-30 psi are also valid for ON-OFF service with air supply at 30/35 psi

COMPONENTS LIST AND MATERIALS

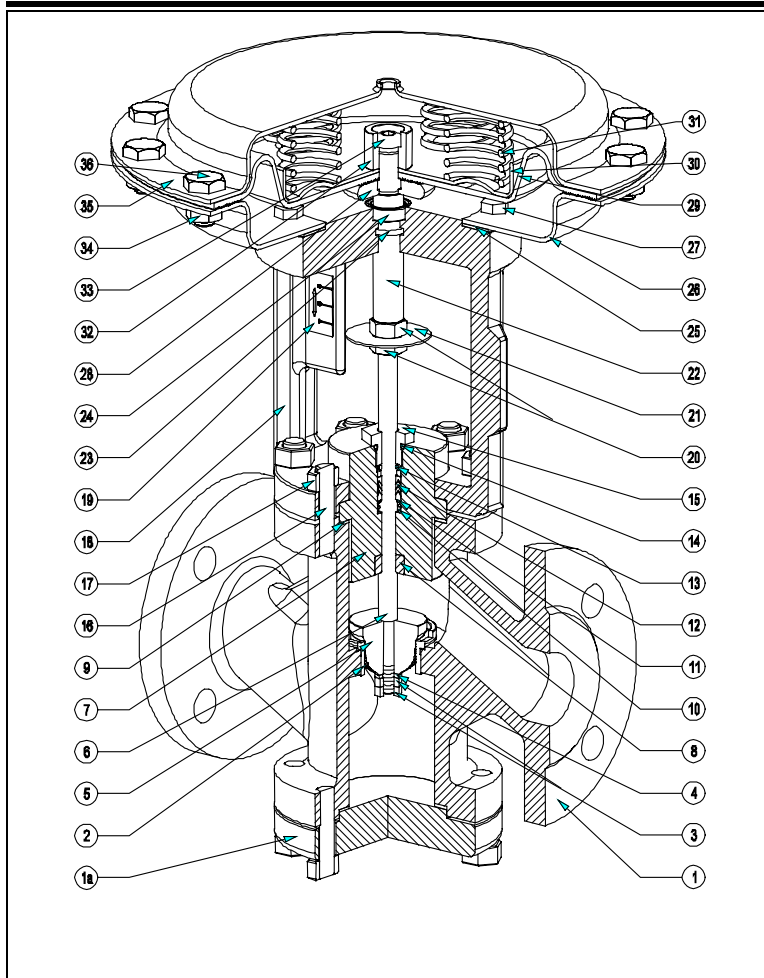

COMPONENTS LIST

MATERIALS

- | | |
|---|-------------------------------|
| 1. Body | 1. See note (1) at page 1 |
| 1a. Bottom flange | 1a. C40 carbon steel |
| 2. Seat | 2. AISI 316 stainless steel |
| 3. Plug locknuts | 3. AISI 304 stainless steel |
| 4. Spring washer | 4. AISI 304 stainless steel |
| 5. Plug | 5. AISI 316 stainless steel |
| 6. Stem | 6. AISI 316 stainless steel |
| 7. Bonnet | 7. See note (1)-(2) at page 1 |
| 8. Guide bush | 8. AISI 304 stainless steel |
| 9. Body gasket | 9. Europil WS 3640 or PTFE |
| 10. Packing spring | 10. AISI 302 stainless steel |
| 11. Packing washer | 11. AISI 304 stainless steel |
| 12. Packing rings | 12. See note (3) at page 1 |
| 13. Internal "O" ring | 13. Viton FPM 70 |
| 14. External "O" ring | 14. Viton FPM 70 |
| 15. Packing adjusting nut | 15. AISI 303 stainless steel |
| 16. Stud-bolts | 16. Galvanized steel |
| 17. Body locknuts | 17. DIN 934 galvanized steel |
| 18. Yoke | 18. GGG50 spheroidal c. iron |
| 19. Travel indicator plate | 19. Polycarbonate |
| 20. Position indicator locknuts | 20. DIN 936 galvanized steel |
| 21. Position indicator | 21. Aluminium |
| 22. Diaphragm rod | 22. AISI 303 stainless steel |
| 23. "O" ring | 23. NBR |
| 24. Airtight | 24. NBR |
| 25. Yoke gasket | 25. Cork - rubber |
| 26. Lower diaphragm casing | 26. P11 steel |
| 27. Lower diaphragm casing internal bolts | 27. DIN 933 galvanized steel |
| 28. Diaphragm spacer | 28. Galvanized steel |
| 29. Diaphragm | 29. EPDM 70 |
| 30. Diaphragm plate | 30. P01 steel |
| 31. Springs | 31. C98 UNI 3823 |
| 32. Diaphragm bush | 32. AISI 303 stainless steel |
| 33. Diaphragm locknut | 33. ISO 7380 galvanized steel |
| 34. Diaphragm casing bolts | 34. DIN 934 galvanized steel |
| 35. Upper diaphragm casing | 35. P11 steel |
| 36. Diaphragm casing locknuts | 36. DIN 933 galvanized steel |

DIMENSIONS in mm.

DN	Ø	A(1)	A(2)	B	C - Bonnet			D	V	V1	Actuator	E	Ø F
					Std	Finned	Bellows						
15	1/2 "	184	190	67	49	181	181	147	166	11	200	70	210
20	3/4 "	184	194	67	58	190	190	147	166	11			
25	1 "	184	197	90	68	200	200	147	166	11	250	70	292
32	1.1/4 "	200	212	92	70	202	202	147	166	19			
40	1.1/2 "	222	235	108	82	214	214	160	166	19	310	95	336
50	2 "	254	267	108	86	218	218	160	166	19			
65	2.1/2 "	276	292	148	111	309	309	160	166	28	400	119	408
80	3 "	298	317	148	135	333	333	160	166	28			
100	4 "	352	368	176	160	363	363	204	166	28	500	119	520
125	5 "	403	425	223	252	435	435	213	166	50			
150	6 "	450	473	229	258	442	442	213	166	50			
200	8 "	543	568	254	283	465	465	213	166	50			

A(1) cast iron = PN16-ANSI150-JIS10K A(2) carbon and st. steel = PN16-PN40-ANSI150-ANSI300-JIS10K-JIS20K
 Specifications given are only indicative and not binding for the manufacturer who reserve the right to carry-out any modification deemed necessary without prior notice