



CE
0102

Model Number

NCN3-F25-N4-5M

Features

- For installation in housing
- Direct mounting on standard actuators
- EC-Type Examination Certificate TÜV99 ATEX 1479X

Connection

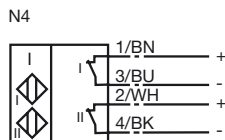

Dimensions

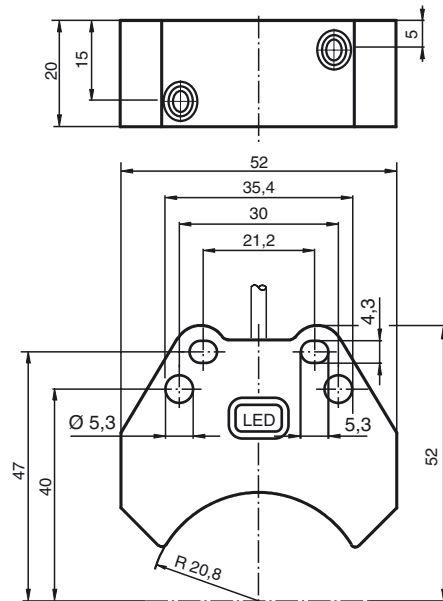

Technical Data

General specifications

Switching element function	DCDual Break function
Rated operating distance	s_n 3 mm
Installation	flush mountable
Output polarity	NAMUR
Assured operating distance	s_a 0 ... 2.43 mm
Reduction factor r_{AI}	0.5
Reduction factor r_{Cu}	0.4
Reduction factor r_{V2A}	1
Reduction factor r_{St37}	1.1

Nominal ratings

Nominal voltage	U_o 8 V
Switching frequency	f 0 ... 1500 Hz
Hysteresis	H typ. 5 %
Reverse polarity protection	protected against reverse polarity
Short-circuit protection	yes
Current consumption	
Measuring plate not detected	≥ 3 mA
Measuring plate detected	≤ 1 mA
Indication of the switching state	LED, yellow

Standard conformity

EMC in accordance with	IEC / EN 60947-5-2:2004; NE 21
Standards	DIN EN 60947-5-6 (NAMUR)

Ambient conditions

Ambient temperature	-25 ... 100 °C (248 ... 373 K)
Storage temperature	-40 ... 100 °C (233 ... 373 K)

Mechanical specifications

Connection type	5 m, PVC cable
Core cross-section	0.75 mm ²
Housing material	PBT
Sensing face	PBT
Protection degree	IP67
Note	Mounted on mechanical drive

General information

Use in the hazardous area	see instruction manuals
Category	1G; 2G; 3G

ATEX 1G

Instruction

Device category 1G

Directive conformity

Standard conformity

CE symbol

Ex-identification

EC-Type Examination Certificate

Appropriate type

Effective internal capacitance C_i Effective internal inductance L_i

Cable length

Explosion group IIA

Explosion group IIB

Explosion group IIC

General

Highest permissible ambient temperature

Installation, Commissioning

Maintenance

Special conditions

Protection from mechanical danger

Electrostatic charging

Manual electrical apparatus for hazardous areas

for use in hazardous areas with gas, vapour and mist

94/9/EG

EN 50014:1997, EN 50020:2002, EN 50284:1999

Ignition protection "Intrinsic safety"

Use is restricted to the following stated conditions

CE 0102

Ex II 1G EEx ia IIC T6

TÜV 99 ATEX 1479 X

NCN3-F25.-N4...

≤ 100 nF A cable length of 10 m is considered.

The value is applicable for the sensor circuit.

≤ 100 μH A cable length of 10 m is considered.

The value is applicable for the sensor circuit.

Dangerous electrostatic charges on the fixed connection cable must be taken into account for lengths equal to and exceeding the following values:

68 cm

34 cm

5 cm

The apparatus has to be operated according to the appropriate data in the data sheet and in this instruction manual.

The EC-Type Examination Certificate has to be observed. The special conditions must be adhered to!

Directive 94/9/EG and hence also EC-Type Examination Certificates apply in general only to the use of electrical apparatus under atmospheric conditions. The use in ambient temperatures of > 60 °C was tested with regard to hot surfaces by the mentioned certification authority.

If the equipment is not used under atmospheric conditions, a reduction of the permissible minimum ignition energies may have to be taken into consideration.

The temperature ranges, according to temperature class, are given in the EC-Type Examination Certificate. Note: Use the temperature table for category 1 !!!

The 20 % reduction in accordance with EN 1127-1:1997 has already been accounted for in the temperature table for category 1.

Laws and/or regulations and standards governing the use or intended usage goal must be observed.

The intrinsic safety is only assured in connection with an appropriate related apparatus and according to the proof of intrinsic safety.

The associated apparatus must satisfy the requirements of category ia.

Due to the possible danger of ignition, which can arise due to faults and/or transient currents in the equipotential bonding system, galvanic isolation of the power supply and signal circuit is preferable. Associated apparatus without electrical isolation must only be used if the appropriate requirements of IEC 60079-14 are met.

No changes can be made to apparatus, which are operated in hazardous areas. Repairs to these apparatus are not possible.

When used in the temperature range below -20 °C the sensor should be protected from knocks by the provision of an additional housing.

When used in group IIC non-permissible electrostatic charges should be avoided on the plastic housing parts.

ATEX 2G

Instruction

Device category 2G

Directive conformity

Standard conformity

CE symbol

Ex-identification

EC-Type Examination Certificate

Appropriate type

Effective internal capacitance C_i Effective internal inductance L_i

General

Highest permissible ambient temperature

Installation, Commissioning

Maintenance

Special conditions

Protection from mechanical danger

Manual electrical apparatus for hazardous areas

for use in hazardous areas with gas, vapour and mist

94/9/EG

EN 50014:1997, EN 50020:2002

Ignition protection "Intrinsic safety"

Use is restricted to the following stated conditions

CE 0102

 II 1G EEx ia IIC T6

TÜV 99 ATEX 1479 X

NCN3-F25.-N4...

 ≤ 100 nF ; a cable length of 10 m is considered. The value is applicable for the sensor circuit. ≤ 100 μ H ; a cable length of 10 m is considered. The value is applicable for the sensor circuit.

The apparatus has to be operated according to the appropriate data in the data sheet and in this instruction manual. The EC-Type Examination Certificate has to be observed. The special conditions must be adhered to!

Directive 94/9/EG and hence also EC-Type Examination Certificates apply in general only to the use of electrical apparatus under atmospheric conditions.

The use in ambient temperatures of > 60 °C was tested with regard to hot surfaces by the mentioned certification authority.

If the equipment is not used under atmospheric conditions, a reduction of the permissible minimum ignition energies may have to be taken into consideration.

The temperature ranges, according to temperature class, are given in the EC-Type Examination Certificate.

Laws and/or regulations and standards governing the use or intended usage goal must be observed. The intrinsic safety is only assured in connection with an appropriate related apparatus and according to the proof of intrinsic safety.

No changes can be made to apparatus, which are operated in hazardous areas. Repairs to these apparatus are not possible.

When used in the temperature range below -20 °C the sensor should be protected from knocks by the provision of an additional housing.

ATEX 3D

Note	This instruction is only valid for products according to EN 50281-1-1, valid until 30-September-2008 Note the ex-marking on the sensor or on the enclosed adhesive label
Instruction	Manual electrical apparatus for hazardous areas
Device category 3D	for use in hazardous areas with non-conducting combustible dust
Directive conformity	94/9/EG
Standard conformity	EN 50281-1-1 Protection via housing Use is restricted to the following stated conditions
CE symbol	CE 0102
Ex-identification	II 3D IP67 T 111 °C X
General	The apparatus has to be operated according to the appropriate data in the data sheet and in this instruction manual. The data stated in the data sheet are restricted by this operating instruction! The special conditions must be adhered to!
Installation, Commissioning	Laws and/or regulations and standards governing the use or intended usage goal must be observed. Each sensor circuit can be operated with the stated maximum values.
Maintenance	No changes can be made to apparatus, which are operated in hazardous areas. Repairs to these apparatus are not possible.
Special conditions	
Minimum series resistance R_V	A minimum series resistance R_V is to be provided between the power supply voltage and the proximity switch in accordance with the following list. This can also be assured by using a switch amplifier.
Maximum operating voltage U_{Bmax}	The maximum permissible operating voltage U_{Bmax} must be restricted to the values given in the following list. Tolerances are not permitted.
Maximum heating (Temperature rise)	Values can be obtained from the following list, depending on the max. operating voltage U_b max and the minimum series resistance R_V .
at $U_{Bmax}=9\text{ V}$, $R_V=562\ \Omega$	11 °C
using an amplifier in accordance with EN 60947-5-6	11 °C
Protection from mechanical danger	The sensor must not be mechanically damaged.
Protection of the connection cable	The connection cable must be prevented from being subjected to tension and torsional loading.

ATEX 3G (nL)

Note

This instruction is only valid for products according to EN 60079-15:2003, valid until 31-May-2008

Instruction**Manual electrical apparatus for hazardous areas****Device category 3G (nL)**

for use in hazardous areas with gas, vapour and mist

Directive conformity

94/9/EG

Standard conformity

EN 60079-15:2003 Ignition protection category "n"

Use is restricted to the following stated conditions

CE symbol

CE 0102

Ex-identification

Ex II 3G EEx nL IIC T6 X

Effective internal capacitance C_i

≤ 100 nF ; A cable length of 10 m is considered.

The value is applicable for the sensor circuit.

Effective internal inductance L_i

≤ 100 μ H ; A cable length of 10 m is considered.

The value is applicable for the sensor circuit.

General

The apparatus has to be operated according to the appropriate data in the data sheet and in this instruction manual. The data stated in the data sheet are restricted by this operating instruction! The special conditions must be observed!

Installation, Commissioning

Laws and/or regulations and standards governing the use or intended usage goal must be observed. The sensor must only be operated with an energy-limited circuit, which satisfies the requirements of IEC 60079-15. The explosion group complies with the connected, supplying, power limiting circuit.

Maintenance

No changes can be made to apparatus, which are operated in hazardous areas. Repairs to these apparatus are not possible.

Special conditions

Maximum permissible ambient temperature T_{Umax} at $U_i = 20$ V

for $P_i=34$ mW, $I_i=25$ mA, T6

for $P_i=34$ mW, $I_i=25$ mA, T5

for $P_i=34$ mW, $I_i=25$ mA, T4-T1

for $P_i=64$ mW, $I_i=25$ mA, T6

for $P_i=64$ mW, $I_i=25$ mA, T5

for $P_i=64$ mW, $I_i=25$ mA, T4-T1

for $P_i=169$ mW, $I_i=52$ mA, T6

for $P_i=169$ mW, $I_i=52$ mA, T5

for $P_i=169$ mW, $I_i=52$ mA, T4-T1

Protection from mechanical danger

Each sensor circuit can be operated with the stated maximum values.

74 °C

89 °C

100 °C

69 °C

84 °C

100 °C

51 °C

66 °C

91 °C

The sensor must not be mechanically damaged.

When used in the temperature range below -20 °C the sensor should be protected from knocks by the provision of an additional housing.

ATEX 3G (ic)

Instruction

Device category 3G (ic)

Directive conformity

Standard conformity

CE symbol

Ex-identification

Effective internal capacitance C_i Effective internal inductance L_i

General

Installation, Commissioning

Maintenance

[Fett]Special conditions

Maximum permissible ambient temperature T_{Umax} at $U_i = 20\text{ V}$ for $P_i=34\text{ mW}$, $I_i=25\text{ mA}$, T6for $P_i=34\text{ mW}$, $I_i=25\text{ mA}$, T5for $P_i=34\text{ mW}$, $I_i=25\text{ mA}$, T4-T1for $P_i=64\text{ mW}$, $I_i=25\text{ mA}$, T6for $P_i=64\text{ mW}$, $I_i=25\text{ mA}$, T5for $P_i=64\text{ mW}$, $I_i=25\text{ mA}$, T4-T1for $P_i=169\text{ mW}$, $I_i=52\text{ mA}$, T6for $P_i=169\text{ mW}$, $I_i=52\text{ mA}$, T5for $P_i=169\text{ mW}$, $I_i=52\text{ mA}$, T4-T1

Protection from mechanical danger

Connection parts

Manual electrical apparatus for hazardous areas

for use in hazardous areas with gas, vapour and mist

94/9/EG

EN 60079-11:2007 Ignition protection category "ic"

Use is restricted to the following stated conditions

 0102

 II 3G Ex ic IIC T6 X
 $\leq 100\text{ nF}$; A cable length of 10 m is considered.

The value is applicable for the sensor circuit.

 $\leq 100\text{ }\mu\text{H}$; A cable length of 10 m is considered.

The value is applicable for the sensor circuit.

The apparatus has to be operated according to the appropriate data in the data sheet and in this instruction manual. The data stated in the data sheet are restricted by this operating instruction!

The special conditions must be observed!

Directive 94/9EG is generally applicable only to the use of electrical apparatus operating at atmospheric conditions.

If the equipment is not used under atmospheric conditions, a reduction of the permissible minimum ignition energies may have to be taken into consideration.

Laws and/or regulations and standards governing the use or intended usage goal must be observed. The sensor must only be operated with energy-limited circuits, which satisfy the requirements of IEC 60079-11. The explosion group complies with the connected, supplying, power limiting circuit.

No changes can be made to apparatus, which are operated in hazardous areas. Repairs to these apparatus are not possible.

Each sensor circuit can be operated with the stated maximum values.

74 °C

89 °C

100 °C

69 °C

84 °C

100 °C

51 °C

66 °C

91 °C

The sensor must not be mechanically damaged.

When used in the temperature range below $-20\text{ }^\circ\text{C}$ the sensor should be protected from knocks by the provision of an additional housing.

The connection parts are to be installed, such that a minimum protection class of IP20 is achieved, in accordance with IEC 60529.