

Ring-Joints RTJ

Ring-joint gaskets are manufactured from a metallic material. The demands on the geometrical accuracy and the surface quality are therefore high. This concerns both the gasket and the sealing section of the flange.

The necessary surface quality depends substantial on the Brinell hardness of the gasket material. We have found that the relation

$$R_z[\mu\text{m}] \leq 300/\text{HB}$$

gives a useful estimation.

A distinction is made between two kinds of ring-joint gaskets and two different calculation methods can be derived thereof:

1. RTJ gaskets with a suitable fitting radius (figure 1)

- a) The convex octagonal RTJ gaskets, profile AR 13, in which the cambered cone case surfaces of the gasket are pressed against the bevel cone case surfaces of the groove during fastening.
- b) The oval ring-joint gasket, our profile A11, in which the ball sealing surfaces are pressed against the cone case surfaces.

At this types the projection of the sealing surface width b_D results from the angle α , which the sealing surface against the force direction (pipe axis) forms as a function of the E-modulus E_D and the number of contacting surfaces n

$$b_D = b_1 + b_2 = 100 \cdot \frac{\sigma}{E_D} \cdot r \cdot n \cdot \sin\alpha.$$

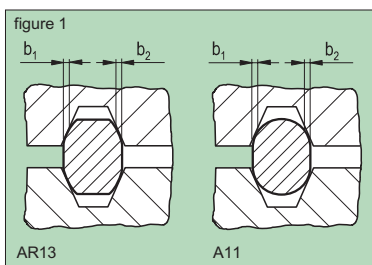

Important:

The surface pressure increase or decreases sub proportional to a possible change of the bolt force.

2. RTJ gaskets with flat sealing surfaces (figure 2)

The octagonal RTJ gasket, our profiles A13 and A14, in which the sealing surfaces are two cone case surfaces. The projection in the direction of the bolting force

$$b_D = b_1 + b_2$$

is to be set as the sealing surface width.

Important: The surface pressure increase or decreases proportional to a possible change of the bolt force.

The calculations according to the preliminary standard DIN 2505 with the gasket parameters k_0 and k_1 , which represent a fictive width, do not deal with the complicated conditions in gaskets with suitable fitting radius.

The application limits of oval and octagonal ring-joint gaskets can be calculated more accurately as a function of the material, diameter, pressure and temperature among other things in accordance with the publication entitled "Optimisation of static gaskets", 3. edition, by Hans-Joachim Tückmantel, published by Kempchen Publishing, Oberhausen 1990, ISBN no. 3-88432-003-3. Here the gasket parameters are replaced by the values σ_v and σ_σ as well as by the previous stated sealing width b_D .

Ring-joint gaskets according to API and ASME standards are mainly used in the petrochemical industry and in refineries as a reliable gasket for pipelines with products.

We are entitled to give our products the API stamp of quality - thus guaranteeing compliance of the design with the latest API standards.

Profile AR 13 with cambered flanks. The advantages when using convex shaped RTJ gaskets are explained in detail in the article entitled "The Latest on Ring-Joint Gaskets" which you can request from us as a special publication.

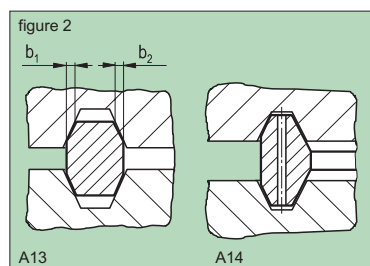

Ring-joint gaskets can also be manufactured as a blind profile A11S, A13S, etc. or as a spectacle-type blind profile A11BS, A13BS, etc.

Disturbing turbulences and deposits are avoided by means of the additional placement of a protector ring made of steel our Profile F 22. In the case of small rim widths the protective gaskets are symmetrical, with larger rim widths they are unilaterally centred.

Soft-iron compensating caps, our profiles AK11, AK12, AK13, AK14, are supplied for damaged grooves.

For comprehensive calculations with regard to sealing flanged connections our gasket calculation service is at your disposal at a favourable price.

kempOchen
the right choice!



Materials, profiles, surface pressure limits, surface roughness

Code designation	Material no.	Hardness (HB)	US Type AISI	Identification
Pure iron e.g. Armco	1.1003	90-100	Soft-iron	D
Low-carbon steel	-	120	Low-carbon steel	S
13 CrMo 4 4	1.7335	< 150	-	7335
12 CrMo 19 5	1.7362	ca. 130	501	F5
X6 Cr 13	1.4000	ca. 160	410	S 410
X5 CrNi 18 10	1.4301	ca. 160	304	S 304
X5 CrNiMo 17 12 2	1.4401	ca. 160	316	S 316
X6 CrNiTi 18 10	1.4541	ca. 160	321	S 321
X6 CrNiNb 18 10	1.4550	ca. 160	347	S 347
X6 CrNiMoTi 17 12 2	1.4571	ca. 160	316 Ti	316 Ti

* See our brochure entitled "Commercial materials" for further technical data

Profile	Cross section
A13	
A13S	
A13BS	
AR13	
A14	
F22	
AK11	
AK12	
AK13	
AK14	

Profile	Cross section
A11	
A11S	
A11BS	
A12	

Compensating caps for damaged grooves

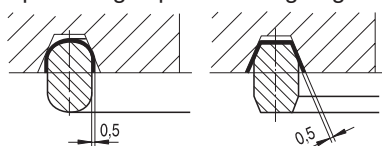

Protective gaskets profile F22

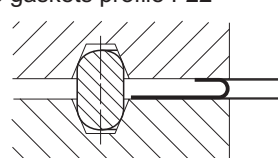

Ring-joint blind profile A11S according to Kempchen drawing D-665

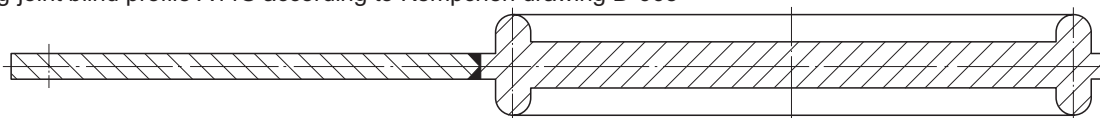

Ring-joint spectacle-type blind profile A11S according to Kempchen drawing D-851

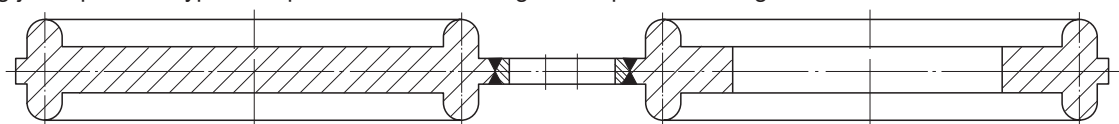

Profile	A11, A11S, A11BS, A12, A13, A13S, A13BS, AR13, AR13S, AR13BS, A14										
Material		Iron 1.1003	High-temperature structural steel 1.5415	High-temperature structural steel 1.7362	Stainless special steel 1.4541	Stainless special steel 1.4828	Copper-coated steel	Stainless steel 1.4541 silver-coated	Copper 2.0090	Monel 2.4360	
Recommended max. surface roughness of the flange surfaces	from	3,2	3,2	3,2	1,6	1,6	3,2	6,3	3,2	3,2	
	to	6,3	6,3	6,3	3,2	3,2	6,3	12,5	6,3	6,3	
Surface pressure limits for 20°C	σ_v	235	300	400	335	400	135	100	135	260	
	σ_0	525	675	900	750	900	600	750	300	660	
E-modulus at 20°C	kN/mm ²	210	210	210	200	200	210	200	128	178	
Surface pressure limits for 300°C	σ_v	235	300	400	335	400	135	100	135	260	
	σ_0	315	585	730	630	750	390	630	150	650	
E-modulus at 300°C	kN/mm ²	185	185	190	186	186	185	186	114	175	

Ring-Joint Gaskets, Type R

Ring-joint gaskets, type R, dimensions according to ASME B16.20, API Std 6 A for flanges to ASME B16.5 and ASME B16.47, series A

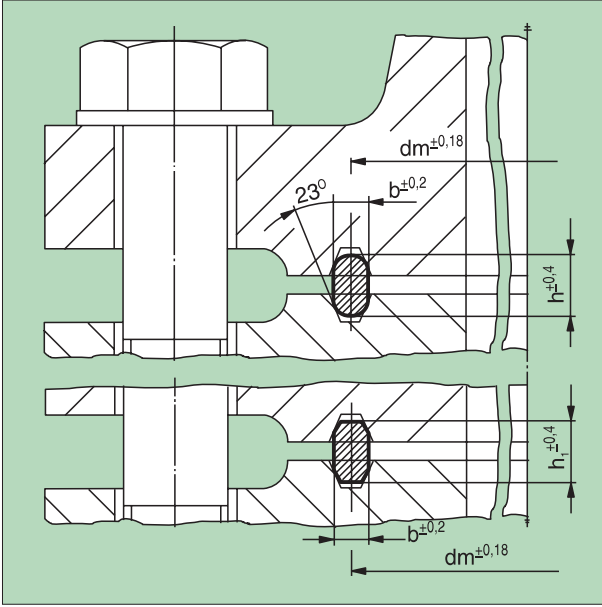

Order example for an oval ring-joint gasket, profile A11, nominal pipe size 5 inches, class 150, made of...¹⁾:

Ring-joint gasket R 40 A11/1.4541

Order example for an octagonal ring-joint gasket, profile A13, nominal pipe size 20 inches, class 1500, made of...¹⁾:

Ring-joint gasket R 75 A13/1.4541

Dimensions in mm						
NPS	class	Ring no.	Ring dimensions			
			dm	b	h	h ₁
1/2	300 to 600	R 11	34,13	6,35	11,11	9,52
	900, 1 500	R 12	39,68	7,93	14,28	12,7
	2500	R 13	42,86	7,93	14,28	12,7
3/4	300 to 600	R 13	42,86	7,93	14,28	12,7
	900, 1500	R 14	44,45	7,93	14,28	12,7
	1	R 15	47,62	7,93	14,28	12,7
1	2500	R 16	50,8	7,93	14,28	12,7
	300 to 1500	R 16	50,8	7,93	14,28	12,7
	150	R 17	57,15	7,93	14,28	12,7
1 1/4	2500	R 18	60,32	7,93	14,28	12,7
	300 to 1500	R 18	60,32	7,93	14,28	12,7
	150	R 19	65,08	7,93	14,28	12,7
1 1/2	300 to 1500	*R 20	68,26	7,93	14,28	12,7
	2500	R 21	72,23	11,11	17,46	15,87
	2	R 22	82,55	7,93	14,28	12,7
2	2500	*R 23	82,55	11,11	17,46	15,87
	300 to 600	*R 23	82,55	11,11	17,46	15,87
	900, 1500	*R 24	95,25	11,11	17,46	15,87
2 1/2	150	R 25	101,6	7,93	14,28	12,7
	2500	*R 26	101,6	11,11	17,46	15,87
	300 to 600	*R 26	101,6	11,11	17,46	15,97
3	900, 1500	*R 27	107,95	11,11	17,46	15,87
	2500	R 28	111,12	12,7	19,05	17,46
	150	R 29	114,3	7,93	14,28	12,7

* These rings comply with API standard 6 A. The dimensions specified in mm are converted dimensions and deviate slightly from the metric API table.

- 1) State material with order
- 2) Ring for flange as per ASME B16.47, series A

Dimensions in mm						
NPS	class	Ring no.	Ring dimensions			
			dm	b	h	h ₁
3	300 to 600	*R 30	117,47	11,11	17,46	15,87
3	300 to 900	*R 31	123,82	11,11	17,46	15,87
3	2500	R 32	127,0	12,7	19,05	17,46
3 1/2	150	R 33	131,76	7,93	14,28	12,7
	300 to 600	R 34	131,76	11,11	17,46	15,87
	1500	*R 35	136,52	11,11	17,46	15,87
4	150	R 36	149,22	7,93	14,28	12,7
	300 to 900	*R 37	149,22	11,11	17,46	15,87
	2500	R 38	157,16	15,87	22,22	20,64
5	1500	*R 39	161,92	11,11	17,46	15,87
	150	R 40	171,45	7,93	14,28	12,7
	300 to 900	*R 41	180,97	11,11	17,46	15,87
6	2500	R 42	190,5	19,05	25,4	23,81
	150	R 43	193,67	7,93	14,28	12,7
	1500	*R 44	193,67	11,11	17,46	15,87
6	300 to 900	*R 45	211,13	11,11	17,46	15,87
	1500	*R 46	211,13	12,7	19,05	17,46
	2500	*R 47	228,6	19,05	25,4	23,81
8	150	R 48	247,65	7,93	14,28	12,7
	300 to 900	*R 49	269,87	11,11	17,46	15,87
	1500	*R 50	269,87	15,87	22,22	20,64
10	2500	R 51	279,4	22,22	28,57	26,99
	150	R 52	304,8	7,93	14,28	12,7
	300 to 900	*R 53	323,85	11,11	17,46	15,87
12	1500	*R 54	323,85	15,87	22,22	20,64
	2500	R 55	342,9	28,57	36,51	34,92
	150	R 56	381,0	7,93	14,28	12,7
12	300 to 900	*R 57	381,0	11,11	17,46	15,87
	1500	R 58	381,0	22,22	28,57	26,99
	150	R 59	396,87	7,93	14,28	12,7
14	2500	R 60	406,4	31,75	39,68	38,1
	300 to 600	R 61	419,1	11,11	17,46	15,87
	900	R 62	419,1	15,87	22,22	20,64
16	1500	*R 63	419,1	25,4	33,33	31,75
	150	R 64	454,0	7,93	14,28	12,7
	300 to 600	*R 65	469,9	11,11	17,46	15,87
18	900	*R 66	469,9	15,87	22,22	20,64
	1500	R 67	469,9	28,57	36,51	34,92
	150	R 68	517,52	7,93	14,28	12,7
20	300 to 600	*R 69	533,4	11,11	17,46	15,87
	900	*R 70	533,4	19,05	25,4	23,81
	1500	R 71	533,4	28,57	36,51	34,92
20	150	R 72	558,8	7,93	14,28	12,7
	300 to 600	*R 73	584,2	12,7	19,05	17,46
	900	*R 74	584,2	19,05	25,4	23,81
24	1500	R 75	584,2	31,75	39,68	38,1
	150	R 76	673,1	7,93	14,28	12,7
	300 to 600	R 77	692,15	15,87	22,22	20,64
24	900	R 78	692,15	25,4	33,33	31,75
	1500	R 79	692,15	34,92	44,45	41,27
	150	R 80	615,95	7,93	14,28	12,7
22	300 to 600	R 81	635,0	14,28	19,05	17,46
	10000	*R 82	57,15	11,11	17,46	15,87
	1 1/2	*R 84	63,5	11,11	17,46	15,87
2	10000	*R 85	79,37	12,7	17,46	15,87
	10000	*R 86	90,49	15,87	20,63	19,05
	3	*R 87	100,01	15,87	20,63	19,05
4	10000	*R 88	123,83	19,05	23,81	22,9
	10000	*R 89	114,3	19,05	23,81	22,9
	5	*R 90	155,58	22,22	26,98	25,4
10	10000	*R 91	260,35	31,75	38,1	36,5
		R 92	228,6	11,11	17,46	15,87
	26	R 93 ²⁾	749,3	19,05	23,81	22,9
28	300, 400, 600	R 94 ²⁾	800,1	19,05	23,81	22,9
	300, 400, 600	R 95 ²⁾	857,25	19,05	23,81	22,9
	300, 400, 600	R 96 ²⁾	914,4	22,22	26,98	25,4
34	300, 400, 600	R 97 ²⁾	965,2	22,22	26,98	25,4
	300, 400, 600	R 98 ²⁾	1022,35	22,22	26,98	25,4
	8	*R 99	234,95	11,11	17,46	15,87
26	900	R 100 ²⁾	749,3	28,57	34,92	33,3
	900	R 101 ²⁾	800,1	31,75	38,1	36,5
	30	R 102 ²⁾	857,25	31,75	38,1	36,5
32	900	R 103 ²⁾	914,4	31,75	38,1	36,5
	900	R 104 ²⁾	965,2	34,92	41,27	39,6
	36	R 105 ²⁾	1022,35	34,92	41,27	39,6

Ring-Joint Gaskets, Type RX

Ring-joint gasket, type RX, dimensions according to ASME B16.20 and/or API Std 6 A for API 6B flanges

Order example for a ring-joint gasket, profile A14, nominal pipe size 5 inches, class 3000, made of...¹⁾:

Ring-joint gasket RX 37 A14/1.4541

1) State material with order

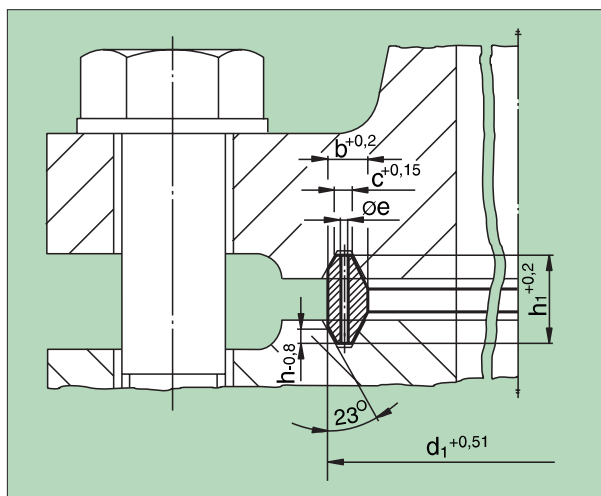

Dimensions in mm								1* drilled hole e
NPS	class	Ring no.	Ring dimensions					
			d_1	b	c	h_1	h	
1 1/2	2000, 3000, 5000	RX 20	76,2	8,73	4,62	19,05	3,18	
2	2000	RX 23	93,27	11,91	6,45	25,4	4,24	
2	3000, 5000	RX 24	105,97	11,91	6,45	25,4	4,24	
3 1/8	5000	RX 25	109,54	8,73	4,62	19,05	3,18	
2 1/2	2000	RX 26	111,92	11,91	6,45	25,4	3,78	
2 1/2	3000, 5000	RX 27	118,27	11,91	6,45	25,4	4,24	
3	2000, 3000	RX 31	134,54	11,91	6,45	25,4	4,24	
3	5000	RX 35	147,24	11,91	6,45	25,4	4,24	
4	2000, 3000	RX 37	159,94	11,91	6,45	25,4	4,24	
4	5000	RX 39	172,64	11,91	6,45	25,4	4,24	
5	2000, 3000	RX 41	191,69	11,91	6,45	25,4	4,24	
5	5000	RX 44	204,39	11,91	6,45	25,4	4,24	
6	2000, 3000	RX 45	221,85	11,91	6,45	25,4	4,24	
6	5000	RX 46	222,25	13,49	6,68	28,58	4,78	
8	crossover flange	RX 47	245,3	19,84	10,34	41,28	6,88	
8	2000, 3000	RX 49	280,59	11,91	6,45	25,4	4,24	
8	5000	RX 50	283,37	16,67	8,51	31,75	5,28	
10	2000, 3000	RX 53	334,57	11,91	6,45	25,4	4,24	
10	5000	RX 54	337,34	16,67	8,51	31,75	5,28	
12	2000, 3000	RX 57	391,72	11,91	6,45	25,4	4,24	
14	5000	RX 63	441,72	26,99	14,78	50,8	8,46	
16	2000	RX 65	480,62	11,91	6,45	25,4	4,24	
16	3000	RX 66	483,39	16,67	8,51	31,75	5,28	
18	2000	RX 69	544,1	11,91	6,45	25,4	4,24	
18	3000	RX 70	550,1	19,84	10,34	41,28	6,88	
20	2000	RX 73	596,1	13,49	6,68	31,75	5,28	
20	3000	RX 74	600,87	19,84	10,34	41,28	6,88	
		RX 82	67,87	11,91	6,45	25,4	4,24	
		RX 84	74,22	11,91	6,45	25,4	4,24	1,6
		RX 85	90,09	13,49	6,68	25,4	4,24	1,6
		RX 86	103,58	15,08	8,51	28,58	4,78	2,4
		RX 87	113,1	15,08	8,51	28,58	4,78	2,4
		RX 88	139,3	17,46	10,34	31,75	5,28	3,2
		RX 89	129,78	18,26	10,34	31,75	5,28	3,2
		RX 90	174,62	19,84	12,17	44,45	7,42	3,2
		RX 91	286,94	30,16	19,81	45,24	7,54	3,2
		RX 99	245,67	11,91	6,45	25,4	4,24	
1 1/4	5000	RX 201	51,46	5,74	3,2	11,3	1,45	
1 3/4	5000	RX 205	62,31	5,56	3,05	11,1	1,83	
2 1/2	5000	RX 210	97,63	9,53	5,41	19,05	3,18	
4	5000	RX 215	140,89	11,91	5,33	25,4	4,24	
4x 4 1/4	5000	RX 215	140,89	11,91	5,33	25,4	4,24	

* A compensating drilled hole on the periphery of the ring.

Ring-Joint Gasket, Type BX

Ring-joint gasket, type BX, dimensions according to API Std 6 A for API 6BX flanges

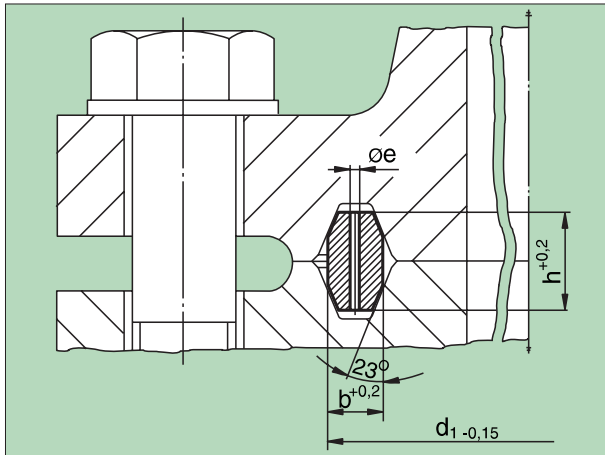

Order example for a ring-joint gasket, profile A12, nominal pipe size 3 1/16 inches, class 15000, made of...¹⁾:

Ring-joint gasket BX 154 A12/1.4541

1) State material with order

Dimensions in mm						
NPS	class	Ring no	Ring dimensions			1* drilled hole
			d1	b	h	e
1 ^{11/16}	10000, 15000	BX 150	72,19	9,30	9,30	1,6
1 ^{13/16}	10000, 15000, 20000	BX 151	76,40	9,63	9,63	1,6
2 ^{1/16}	10000, 15000, 20000	BX 152	84,68	10,24	10,25	1,6
2 ^{9/16}	10000, 15000, 20000	BX 153	100,94	11,38	11,38	1,6
3 ^{1/16}	10000, 15000, 20000	BX 154	116,84	12,40	12,40	1,6
4 ^{1/16}	10000, 15000, 20000	BX 155	147,96	14,22	14,22	1,6
7 ^{1/16}	10000, 15000, 20000	BX 156	237,92	18,62	18,62	3,2
9	10000, 15000	BX 157	294,46	20,98	20,98	3,2
11	10000, 15000	BX 158	352,04	23,14	23,14	3,2
13 ^{5/8}	10000	BX 159	426,72	25,70	25,70	3,2
13 ^{5/8}	5000	BX 160	402,59	13,74	23,83	3,2
16 ^{3/4}	5000, 10000	BX 161	491,41	16,20	28,07	3,2
16 ^{3/4}		BX 162	475,49	14,22	14,22	1,6
18 ^{3/4}	5000	BX 163	556,16	17,37	30,10	3,2
18 ^{3/4}	10000	BX 164	570,56	24,59	30,10	3,2
21 ^{1/4}	5000	BX 165	624,71	18,49	32,03	3,2
21 ^{1/4}	10000	BX 166	640,03	26,14	32,03	3,2
26 ^{3/4}	2000	BX 167	759,36	13,11	35,86	1,6
26 ^{3/4}	3000	BX 168	765,25	16,05	35,86	1,6
5 ^{1/8}	10000	BX 169	173,52	12,93	15,84	1,6
9	2000, 3000	BX 170	218,03	14,22	14,22	1,6
11		BX 171	267,44	14,22	14,22	1,6
13 ^{5/8}		BX 172	333,07	14,22	14,22	1,6
30		BX 303	852,75	16,97	37,95	1,6

* A compensating drilled hole on the periphery of the ring.

Our special service for you

$$F_{SO} \cong d_D \cdot \pi \cdot b_V \cdot \sigma_V \cdot U_{SO} = d_D \cdot \pi \cdot b_V \cdot \sigma_{\min}$$

$$F_{SO} \cong d_D \cdot \pi \cdot b_\vartheta \cdot \frac{\sigma_\vartheta}{U_{SO}} = d_D \cdot \pi \cdot b_\vartheta \cdot \sigma_{\max}$$

$$\sigma_{\min} \cong \frac{F_{P_i}}{F_{P_p}}$$

$$\sigma_{\max} \cong \left(\frac{F_l}{F_p} \right)$$



Due to our field sales staff and our **experienced engineering** consultancy service we are familiar with all the acute problems of our customers and are in a position to recommend the latest developments in sealing technology.

For complicated gasket joints we will calculate the necessary bolting loads.

In our **comprehensive warehouse** we have a great many standard and even **non-standard dimensions** ready for you to call off. Our stock of semi-finished goods has a varied assortment in order to be able to supply you as quickly as possible.



At our disposal we have **up-to-date machines** and our experienced specialist employees in production are the guarantee of our high quality.

- We have a documented quality assurance system and have received certification according to DIN EN ISO 9001:2000. The quality assurance measures that are described therein are continuously updated. Among others we have the following approvals:
- KTA 1401 from Siemens-KWU for nuclear power plants
 - QSP 4a from Siemens-KWU for nuclear power plants
 - API Spec Q1/Spec. 6A from Third Party for the oil industry
 - RAL-GZ 719 quality seal from VGB for soft material compensators

kempchen only uses tried and tested materials, which are also subjected to continuous inspection in our modern chemical and physical laboratory.

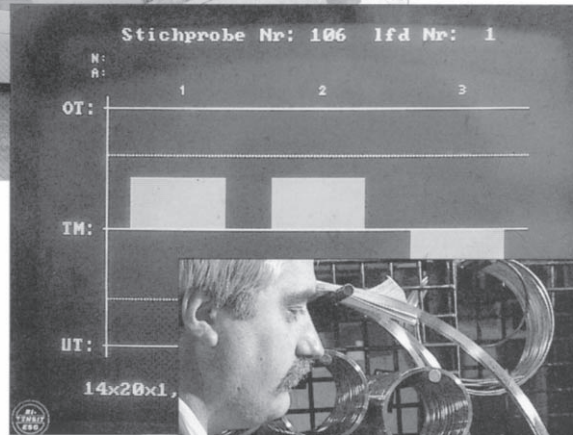

kempchen & Co. GmbH
 Alleestr.4 • D-46049 Oberhausen
 Tel.: ++49 208 8482-0 • Fax ++49 208 8482-285
 E-mail: info@kempchen.de
 URL: www.kempchen.de

kempchen
the right choice!

Gaskets • Packings • Expansion Joints • Rubber and Plastic Parts