

*Mounting and operating instructions for*

**KLINGER**  
**Ballostar-ball valves**  
**standard and high temperatur**  
**Two part model DN 125 - 1000**

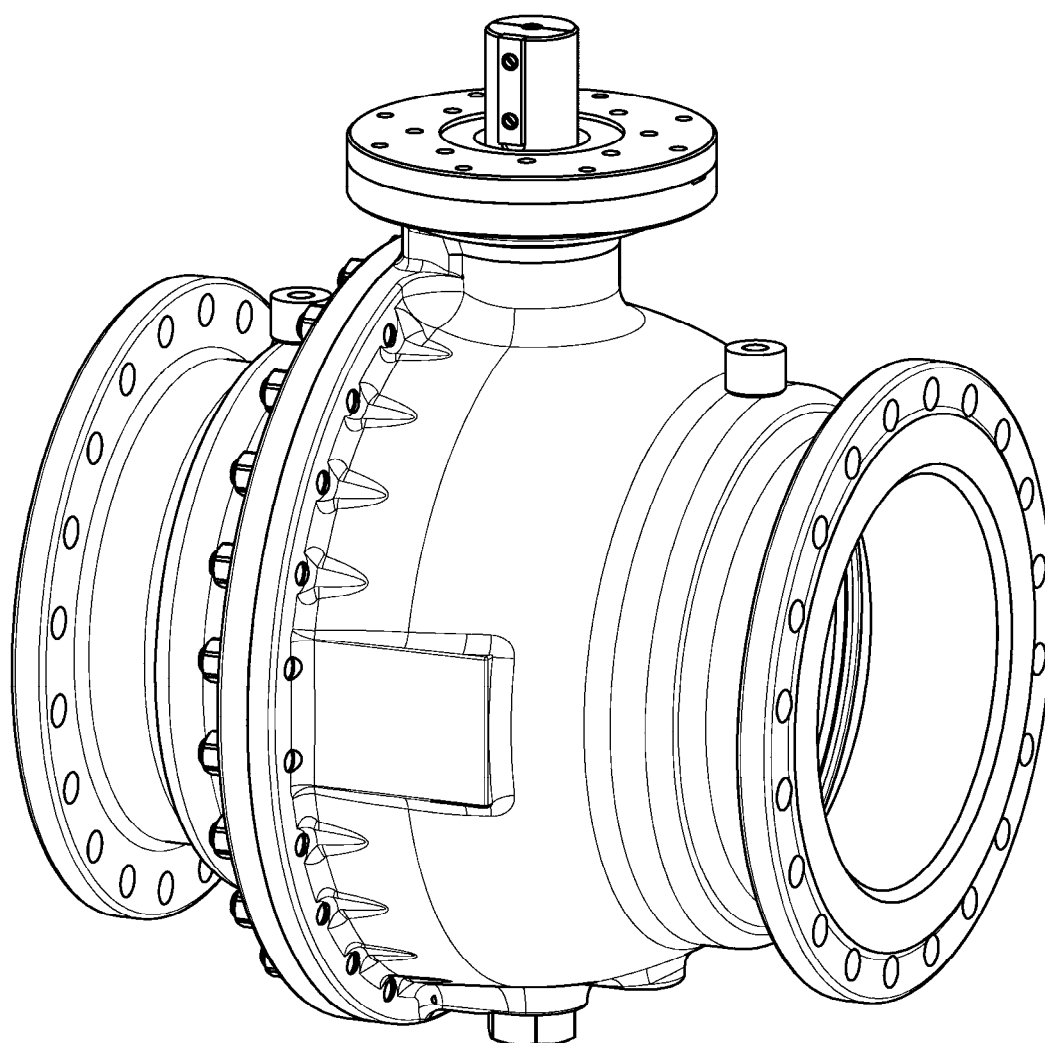

*Edition: 09/2008*



**Fluid Control GmbH**  
**Am Kanal 8-10**  
**A-2352 Gumpoldskirchen/AUSTRIA**

Telefon: ++43(0) 2252 / 600 - 0  
Telefax: ++43(0) 2252 / 63336  
          ++43(0) 2252 / 600 - 242  
e-mail: [office@klinger.kfc.at](mailto:office@klinger.kfc.at)  
WEB: [www.klinger.kfc.at](http://www.klinger.kfc.at)

## TABLE OF CONTENTS

<i>Page</i>	<i>3</i>	<i>Functional principle</i>
<i>Page</i>	<i>4 – 6</i>	<i>Mode of operation</i>
<i>Page</i>	<i>7 – 8</i>	<i>Operation instructions</i>
<i>Page</i>	<i>9 – 10</i>	<i>Installation instructions</i>
<i>Page</i>	<i>11</i>	<i>Commissioning and Safety Instructions</i>
<i>Page</i>	<i>12</i>	<i>Disassembly drawing</i>
<i>Page</i>	<i>13 – 19</i>	<i>Spare parts assembly</i>
<i>Page</i>	<i>20</i>	<i>Installation instructions for actuator assembly</i>
<i>Page</i>	<i>21</i>	<i>Material code numbers</i>
<i>Page</i>	<i>22</i>	<i>Component parts designation and material</i>
<i>Page</i>	<i>23 – 35</i>	<i>Spare parts</i>

---

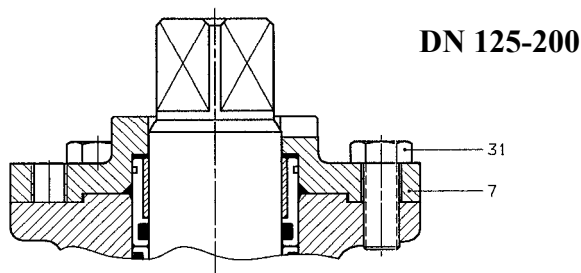

DN 125-200

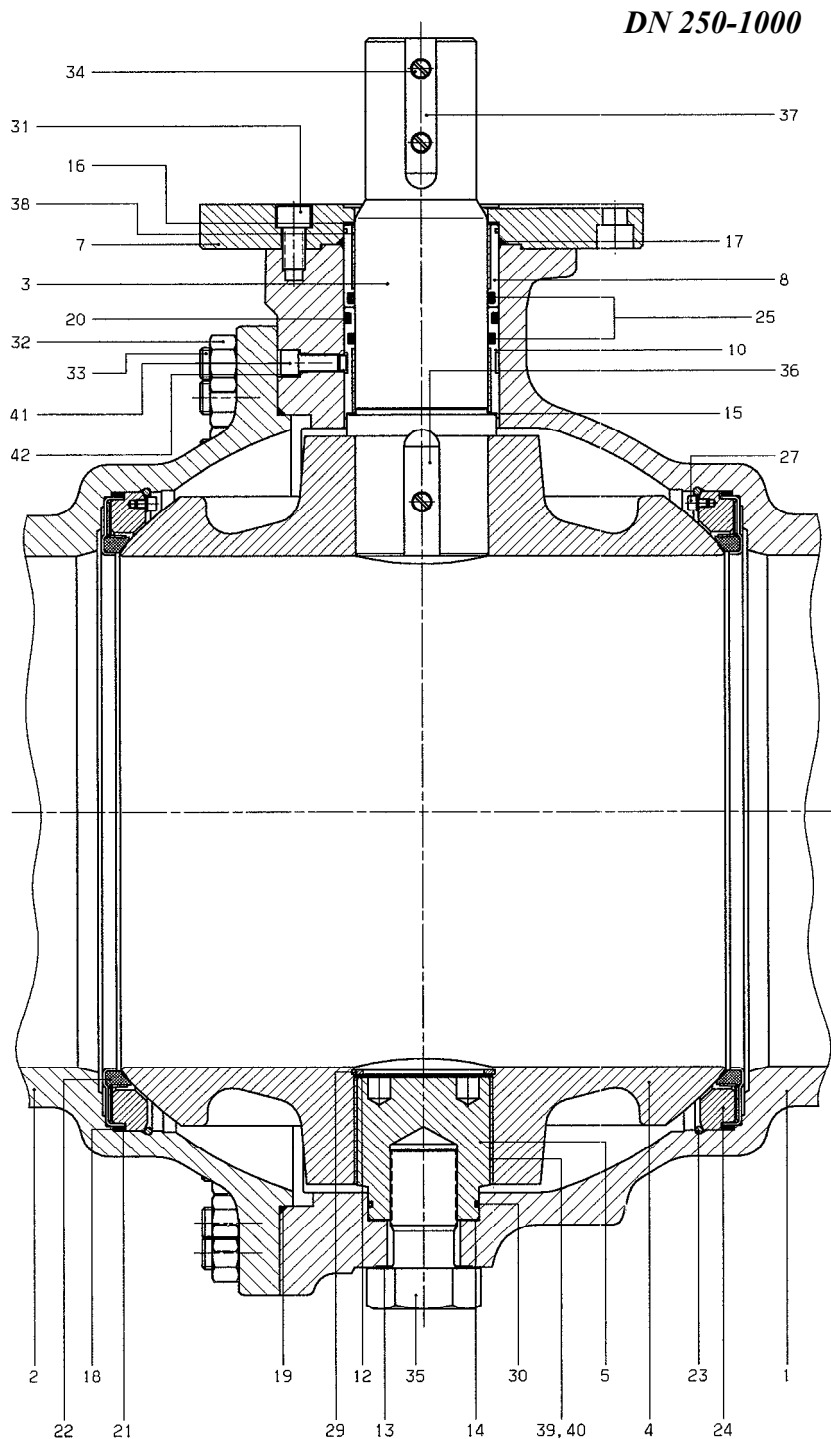

DN 250-1000

- 1 Body
- 2 Single-ended flanged nipple
- 3 Operating stem
- 4 Ball
- 5 Bearing journal
- 7 Flange
- 8 Bush insert, upper part
- 10 Bush insert lower part
- 12 Disk
- 13 Gasket
- 14 Gasket
- 15 Cushion joint
- 16 Cushion joint
- 17 O-ring
- 18 O-ring (spiral wound gasket at WI)
- 19 O-ring
- 20 O-ring
- 21 U-sleeve
- 22 Sealing element
- 23 Wire ring
- 24 Back-up ring
- 25 O-ring
- 26 Rating plate
- 27 Fillister head screw
- 28 Grooved drive stud
- 29 Circlip
- 30 O-ring
- 31 Fillister head screw
- 32 Hexagon nut
- 33 Stud
- 34 Fillister head screw
- 35 Hexagon head screw
- 36 Feather key
- 37 Feather key
- 38 Bearing bush
- 39 Bearing bush
- 40 Bearing bush
- 41 Locking screw
- 42 Gasket

### **Functional principle**

The ball valve guarantees tightness under exposure both high and low pressures through its “ELASTIC SEALING SYSTEM”. This tightness is achieved with two elastic sealing elements which work independently of one another. The required application forces are generated first by applying an initial stress during the assembly, and second by the differential pressure arising in the valve fitting (Figure 1).

Comprised of the shut-off cross section multiplied by the pending differential pressure, the forces coming about on the shut-off ball valve are not conveyed to the sealing rings, but directly to the ball bearings which were installed for this very purpose. As a result, the bearing and sealing functions are separated by design. This keeps the torque required for swivelling the shut-off fitting low. The closing behaviour of these ball valves with balls running on bearings gives them a long service life.

**Figure 1**

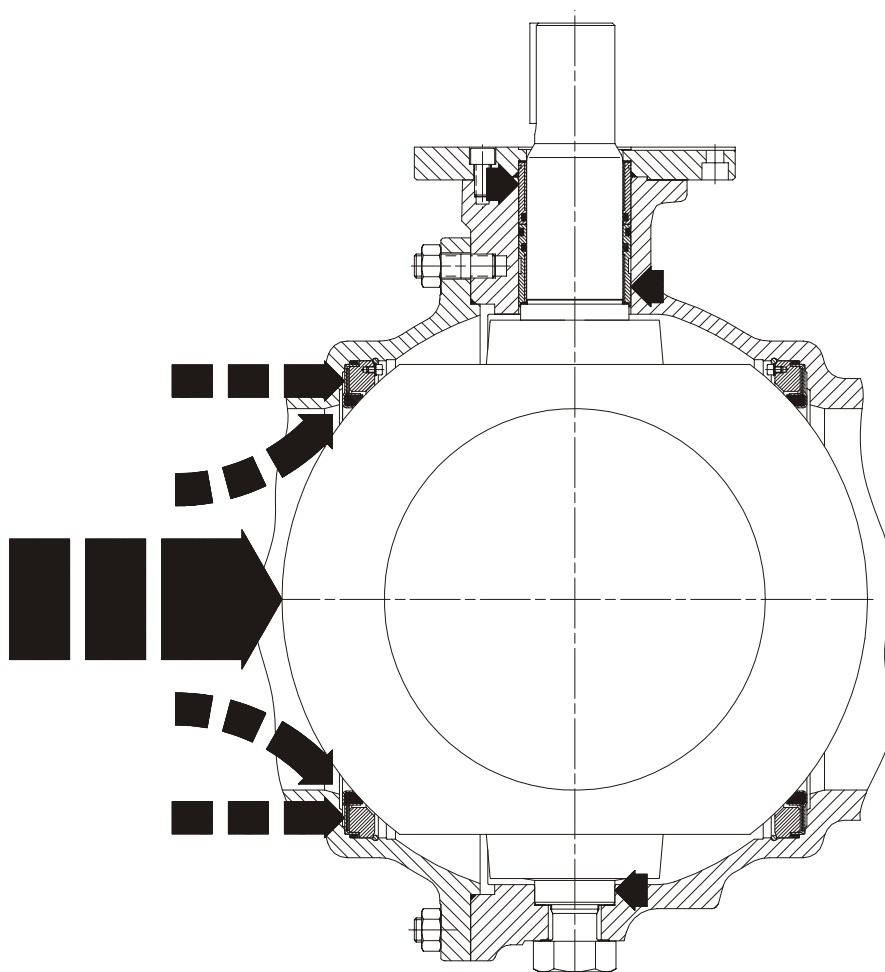

## MODE OF OPERATION

During the assembly of the body and connection piece, the sealing system is elastically at the ball. The two prestressed elastic sealing elements made of stainless steel in conjunction with the sealing rings and a seal at the periphery of the outer diaphragm form a system with the ball on the inlet and outlet side of the ball valve. A back-up ring protects the elastic sealing elements against excess stress, while a wire ring acts to hold the sealing unit in place (Figure 2).

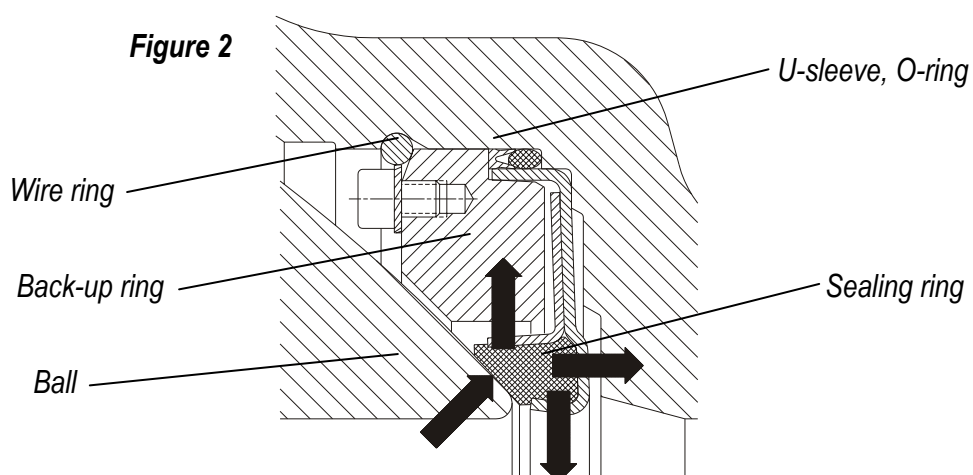

As a result of the elasticity, two primary sealing points are always present of the valve opening up to a certain pressure. The differential surface areas on the sealing elements cause the pressure of the medium to press the sealing ring against the ball surface on the inlet side of the ball valve. The sealing element arranged on the side not exposed to the pressure or outlet side is lifted by the ball surface when the clearance space between the sealing ring is exposed to a pressure exceeding the nominal pressure.

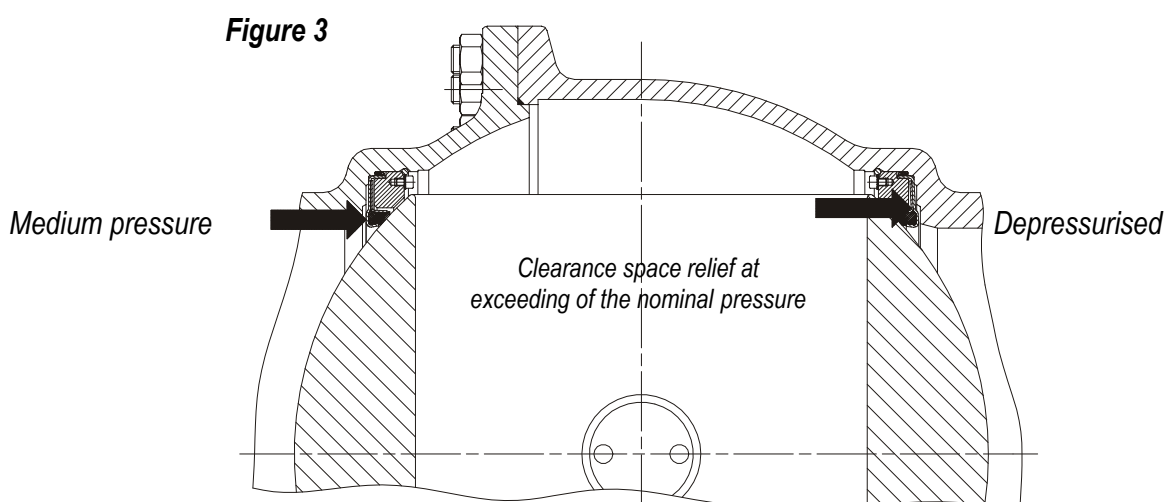

The ball valve may be pressurised in both directions of flow. Heat expansions are compensated by the elasticity of the sealing elements.

The special sealing system allows you to evacuate, vent or pressure-relieve the ball valve clearance space by the way of a discharge connection with the valve fitting closed. This makes it possible to check the function of the two sealing rings after relieving the pressure (Block & Bleed).

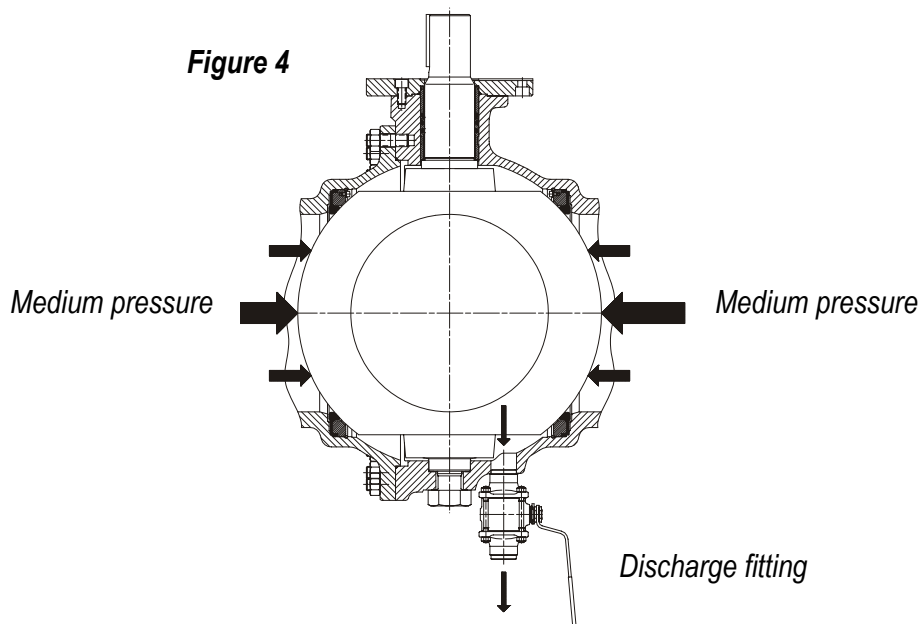

Repairs on a relieved section of line between two ball valves may also be safely done on the side of the line exposed to pressure without the medium penetrating into the section under repair.

The operating stem is used to switch the ball. The shaft-hub connection is established with the feather keys. The seal to the outside is brought about with O-rings arranged in series. These O-rings are placed in a bush insert for easier replace ability. The arising forces are absorbed by two dry lubrication bearings.

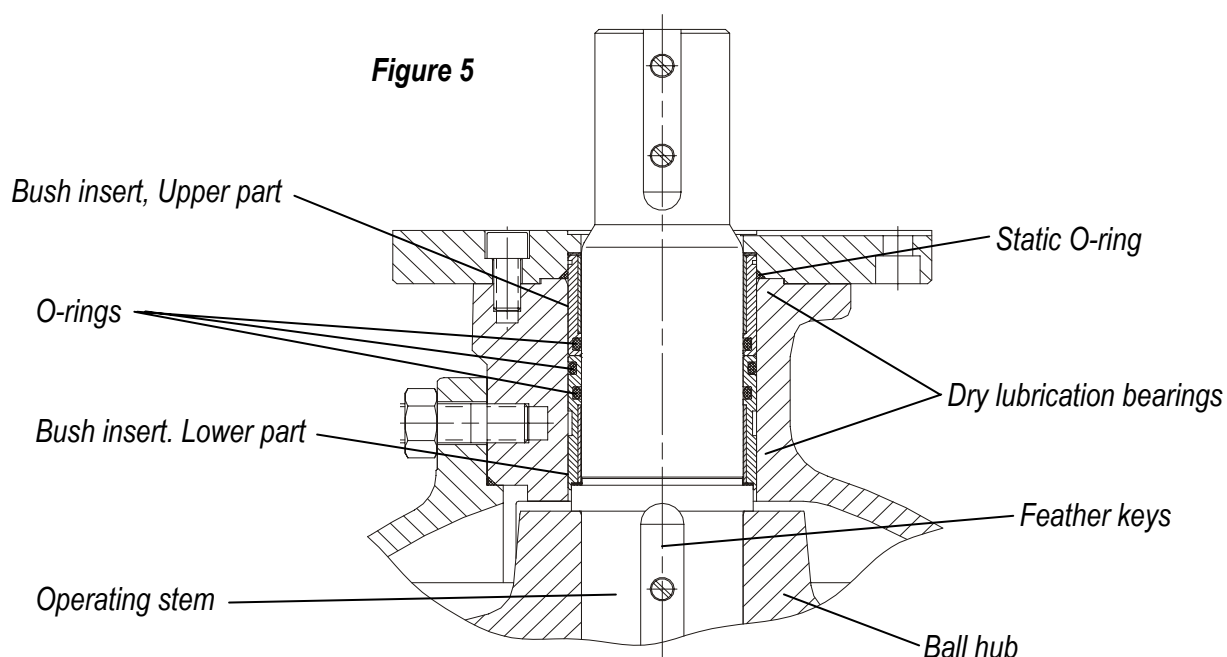

In order to ensure a concentric position of the balls, the opposite side has a bearing journal attached to it, which is routed into the vertical boring of the ball by way of a dry lubrication bearing, and fixed into position against arising forces in the body with a hexagon head screw. The seal to the outside is established with gaskets or an O-ring.

The division between the body and the connection piece is sealed by means of a static O-ring. The parts are held together with a screwed connection, i.e. the metallic flanges are pressed on one another over the entire surface area. This surface area absorbs the arising tensile and bending forces.

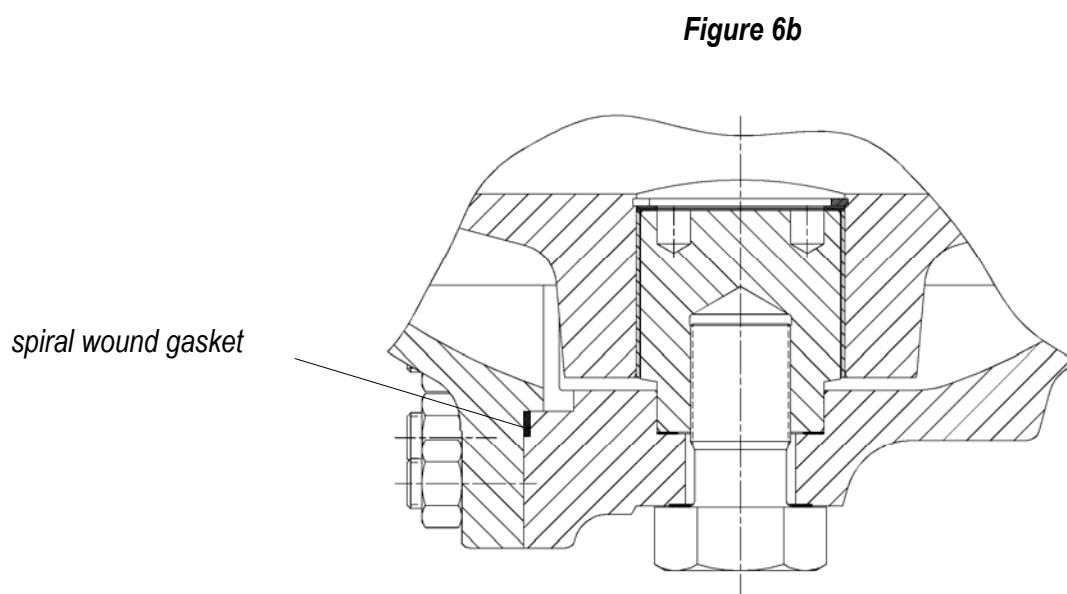
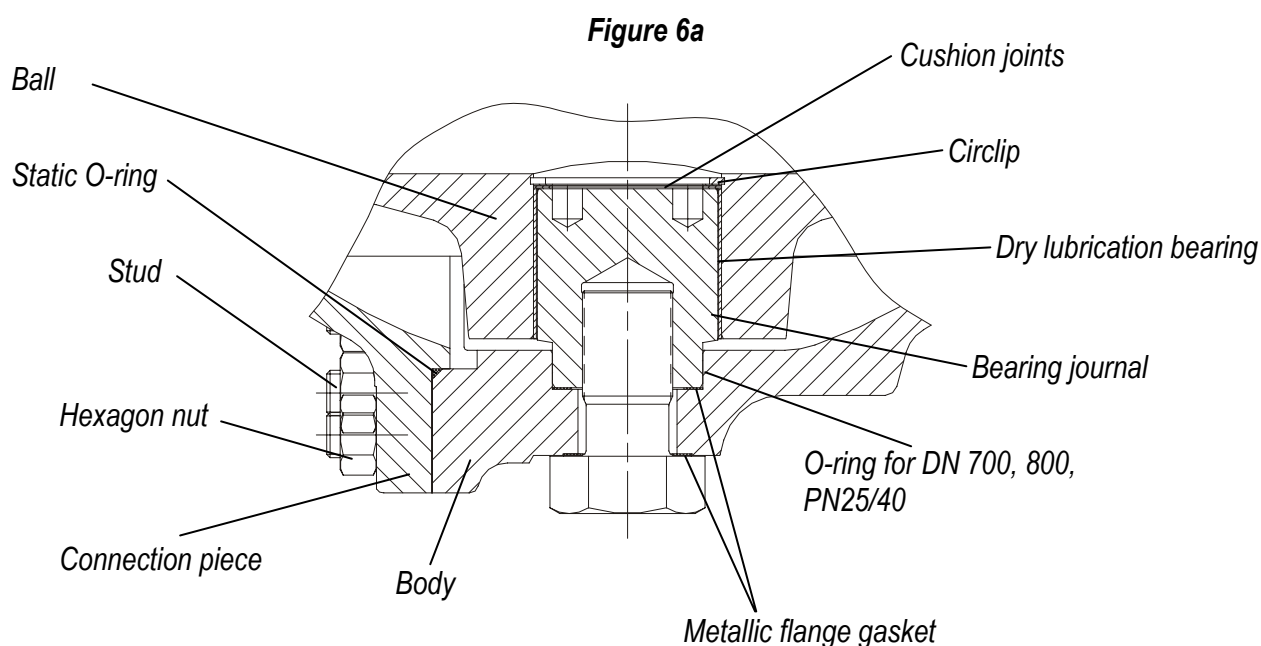

**All seals and bearings are MAINTENANCE FREE.**

## OPERATING INSTRUCTIONS

Ballostar ball valves are delivered in the OPEN setting. The connections are covered to safeguard against contamination and damage. We recommend that these plugs only be removed shortly before installing the valve fitting.

The ball valves are to be stored in closed areas with non-aggressive atmosphere and protected against moisture and contamination. In addition, one must make sure not to use the valve fitting for higher temperatures and pressures than intended. Only under these conditions can a warranty be extended for the indicated time.

Parts subjected to corrosion, erosion, etc. during operations or to natural wear are excluded.

### **Ball valves are MAINTENANCE FREE!**

During prolonged standstills, the valve fitting must be emptied for freezing media, while pressure relief must be provided for expanding media.

In the event of leaks to the outside, the torques of the screws have to be checked at the appropriate locations according Tables 1,2 and 3.

**To increase the live time in service with lo quantity of operations, Klinger suggest to operating the ball valve from time to time.  
It is sufficiently to move the ball only some degree of an angle (to break free)**

**Table 1 Torques of the dividing flange bolts (item33)**

Nominal Width of ball	Dimension	Torques	
		VII, VIII, X	Xc
125,150	M 16	160	94
200	M 20	310	142
250	M 22	320	142
300	M 24	470	228
350	M 22	320	189
400	M 27	650	255
500	M 30	1000	
600	M 33	1400	
700	M 36	1900	
800	M 39	2200	
1000	M39	1800	

**see page 22  
for explanation to material  
code numbers**

**Table 2 Torque of bearing journal screw (item 35)**

Nominal width of ball	Dimension	Torques (Nm)	
		VII, VIII, X	Xc
125,150	M 24	270	270
200	M 30x2	540	540
250,300	M 36x1,5	900	900
350,400	M 48x1,5	2100	2100
500,600	M 60x2	5300	
700,800	M 85x2	19800	
1000	M 95x2	21000	

**Table 3 Torque of mounting flange bolt (item 31)**

Nominal width of ball	Dimension	Torques (Nm)	
		VII, VIII, X	Xc
125,150	M 12	28	39
200	M 16	68	94
250,300	M 16	220	94
350,400	M 20	428	142
500,600	M 20	428	
700,800	M 30	1478	
1000	M 36	950	

**Table 4 Torque of locking screw (item 41)**

Nominal width of ball	Dimension	Torques (Nm)	
		VII, VIII, X	Xc
150	M 8 x 12	27	12
200	M 8 x 20	27	12
250	M 10 x 20	52	24
300	M 10 x 25	52	24
350,400	M 12 x 45	91	39
500	M 16 x 45	220	
600	M 16 x 55	220	
700,800	M 20 x 40	428	
1000	M 20 x 40	428	

## INSTALLATION INSTRUCTIONS

The ball valves are delivered in the OPEN setting with a sealed valve opening.

### INSTALLATION:

Ballostar ball valves may be installed in any desired position. They should be in OPEN setting during the installation to prevent damage to the ball surface. The cover discs are only to be removed just prior to installation.

- Pulleys appropriate for the weight and the eyebolts located on the ball are used for manipulation purposes. See Klinger catalogue for standard ball valve weights.

Figure 7

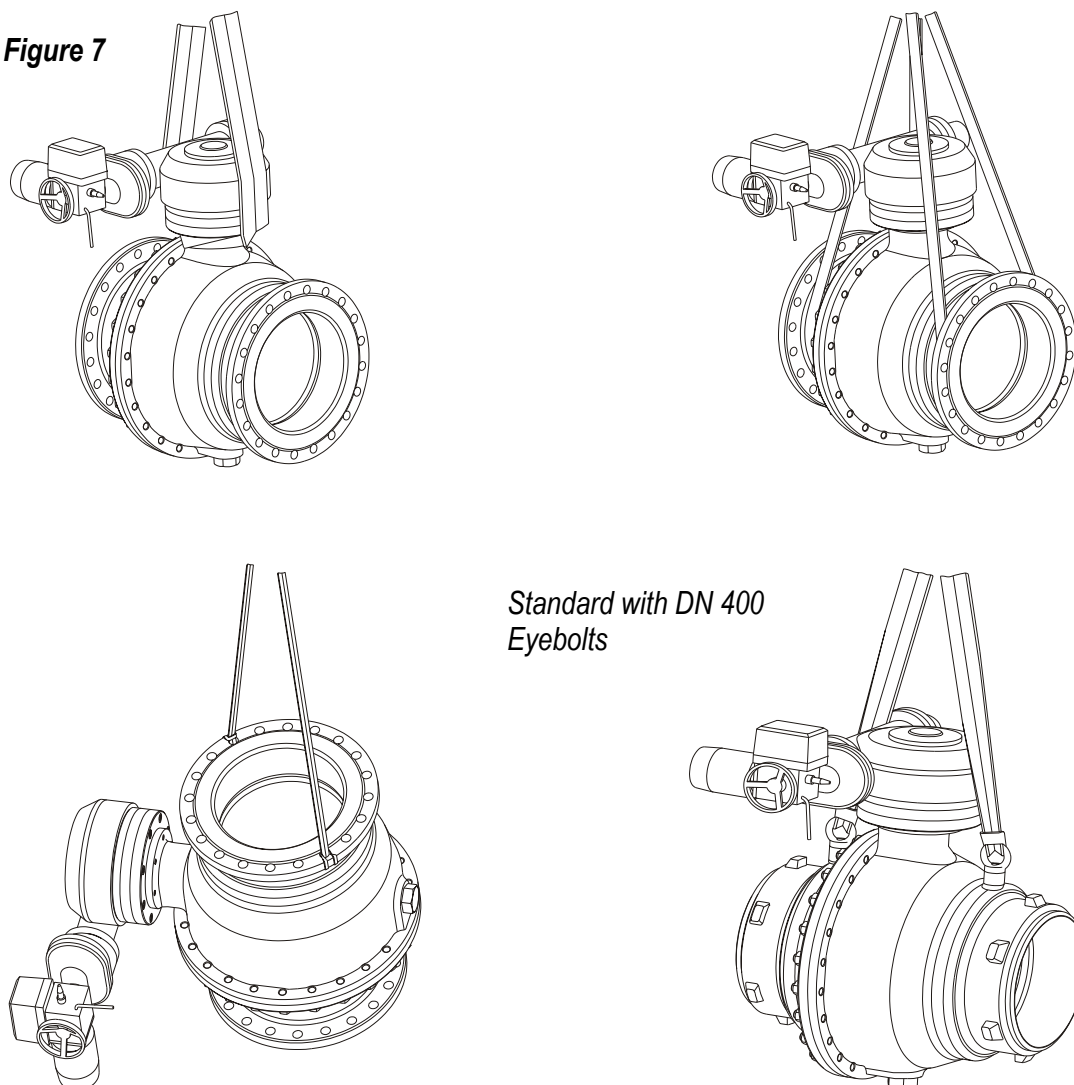

Eyebolts can be provided for all nominal widths at the request of the customer.

---

- Follow the attached welding instructions during installations for ball valves with welded ends.

Because of the overall length selected for this type of ball valve the device need not to be dismantled if it is welded in a workman-like manner, but instead it should may be welded into the pipeline as a complete valve fitting.

The temperature while preheating and welding should not exceed 200°C at a distance of 115 mm from the weld up to DN350, and at a distance of 170 mm starting at DN 400.

Take care of welding quality-requirements according to the welding manual.

We can only guarantee the tightness of our ball valves if they are welled skilfully.

**Figure 8**

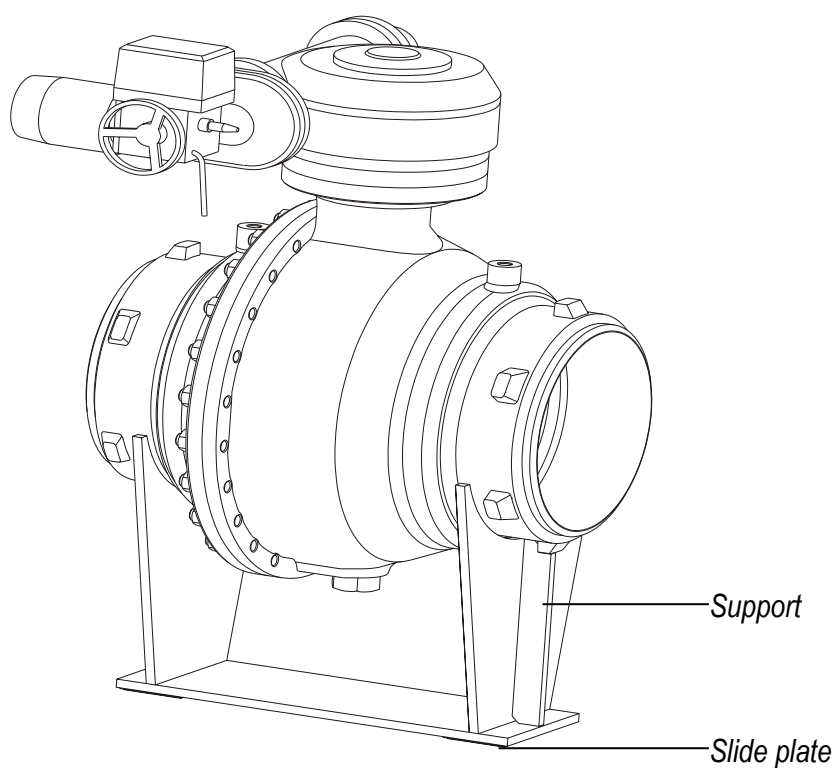

## COMMISSIONING

- *After installation and before commissioning, make sure that solid, not constituting part of the medium are removed from the pipeline.*
- *Functional test*
- *Pressure test*

*We remind you that damage caused by parts strange to the medium are not covered under our warranty.*

### **Safety Instructions**

*In general the using of these valves is without any risks. For this it is necessary to act with enough care.*

- *For the respective application of the valves please take care of the **Safety Directions** for pressure/temperature limits and the selection of materials in the relevant product catalogue.*
- *Be careful in case of the use of cast iron for pressure wetted parts. This material is a rigid material and very sensitive against rapidly pressure changings and tensile peaks. At the building of the network care has to be taken, to avoid pressure impacts (water hammers).*
- ***The mounting and installation can be done ONLY when the pipe is completely empty and pressure released.***
- *Do not untighten any screws on pressure tightening parts, unless advised and described in the Assembly Instructions and Handling Regulations.*
- *The Assembling as well as handling should be done only by qualified people.*
- *Please do make sure that all connecting pieces are well tightened again, if you had to untighten them before.*
- *Do not open any screws with violence.*
- ***ATTENTION*** – *when opening and closing drain cocks – DANGER caused by leakage of Medium. If the valve is used in superheated water, the drain cock may only opened if an appropriate backpressure is in the drainpipe or the temperature of the medium is lower than 100°C (prevention of steam hammer in the dead camber*
- ***ATTENTION*** – *take care with movable parts : specially with electric/pneumatic actuators  
YOU MIGHT HIRT YOURSELF!!!*

*This Assembly Instructions and Handling Regulations has to be passed over to the people working with this valves.*

***ATTENTION:*** *as per dismantling the actuator and before the connecting screws are to be unscrewed, the actuator has to be secured in his mounting position against distortion*

---

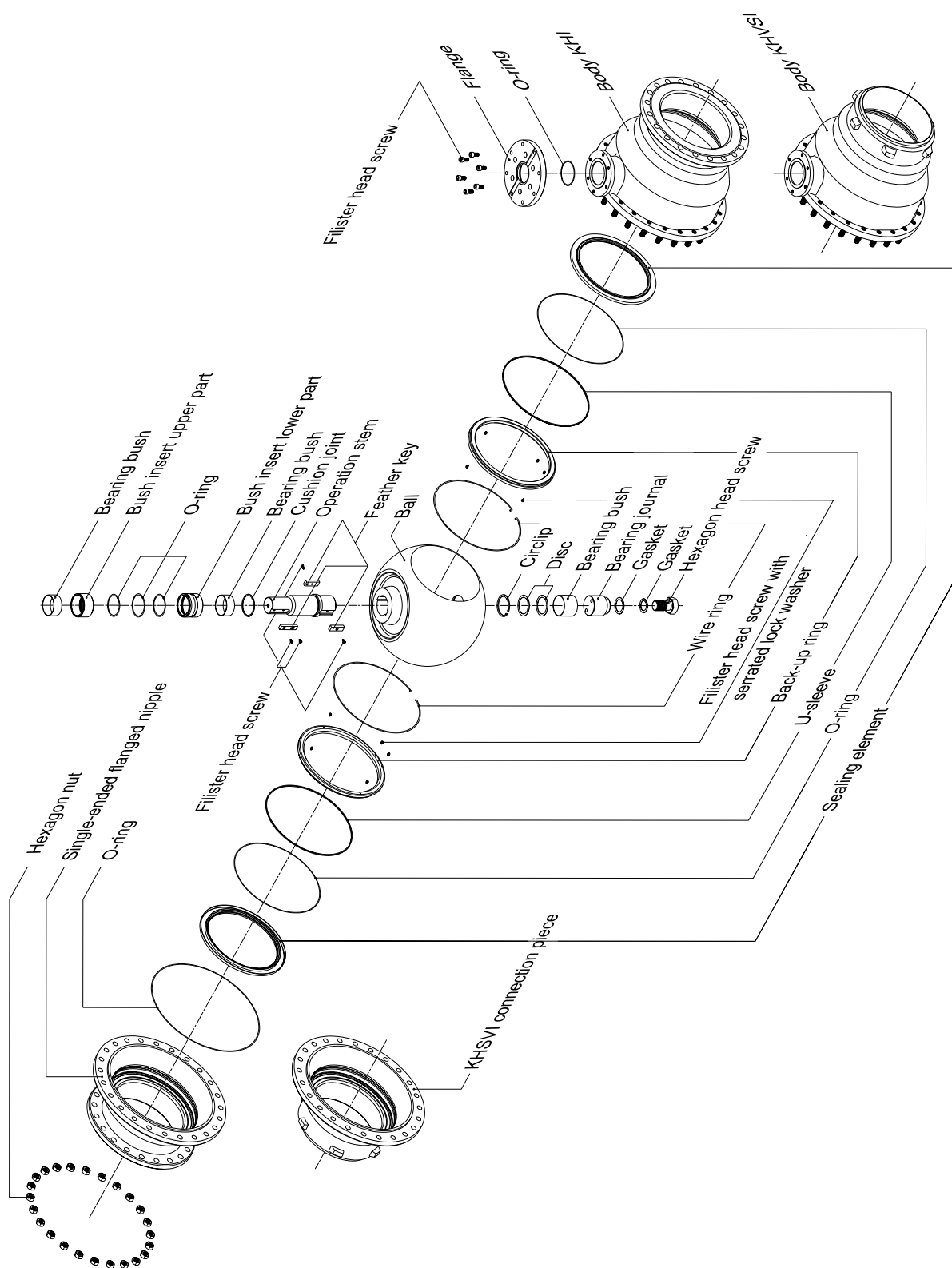

## SPARE PARTS ASSEMBLY

SEAL REPLACEMENT on the operating stem with the valve fitting installed.

### Bush inserts – upper part (item 8)

- Depressurise the line
- Switch valve fitting to OPEN setting
- Dismantle cock handle or drive unit
- Loosen mounting flange bolts (item 31) and take off flange (item 7) with sealing ring (item 17) over the shaft end.
- Remove cushion joints (item 16). The same number of identical cushion joints must be installed again during assembly.
- Pull bush inserts, upper part (item 8) out of body using extraction groove.
- Replace seals (items 20,17) according to spare parts list. Clean components thoroughly and lubricate with the corresponding grease to facilitate installation
- Check the bearing surface (item 38). Replace the bearing if damage is present
- Rebuild in reverse order

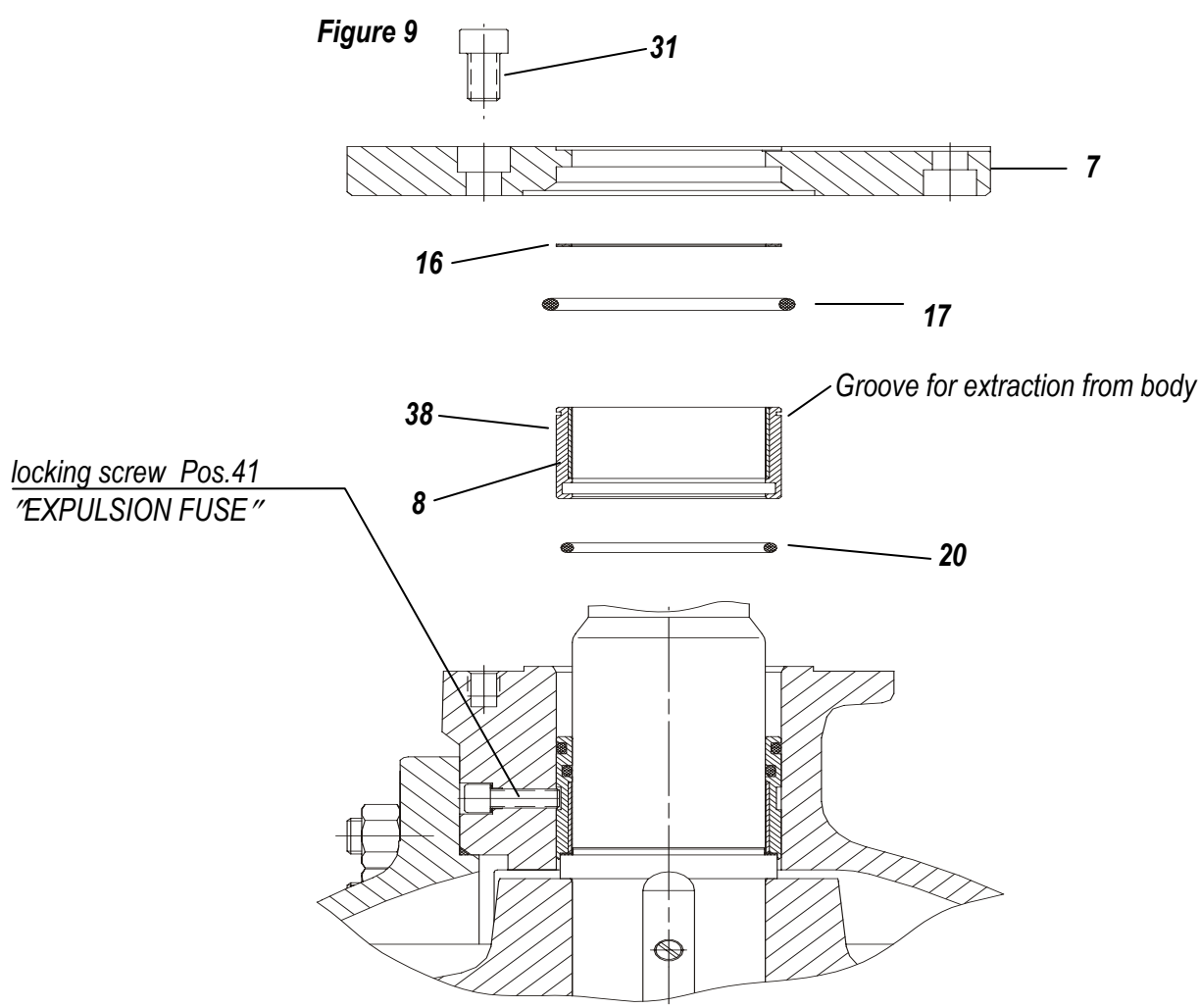

The seal may be placed on the bush insert, upper part under operating conditions for the version having a bush insert, lower part safeguarded against expulsion given the use of harmless media.

If the valve fitting has been dismantled from the line, we also recommend that the spare parts on the bush insert lower part be replaced (item 12)

**Prior bush insert variants for WKZ VIII, X, Xc up until 1992.**

These should be replaced with the new version corresponding to the material code number in the event of disassembly and damage.

## DISASSEMBLY OF COMPONENTS

When replacing the sealing elements the following steps have to be taken:

- Switch ball valve to OPEN setting
- Depressurise line
- Dismantle valve fitting from pipeline. Place on the body connection side for easier handling while dismantling the components. Use a support which doesn't damage the bearing surface.
- Identify the areas where the parts were removed in relation to each other (I) (Figure 10) Loosen hexagon nuts (item 32), lift single-ended flanged nipple (item 2) and place on the connection side

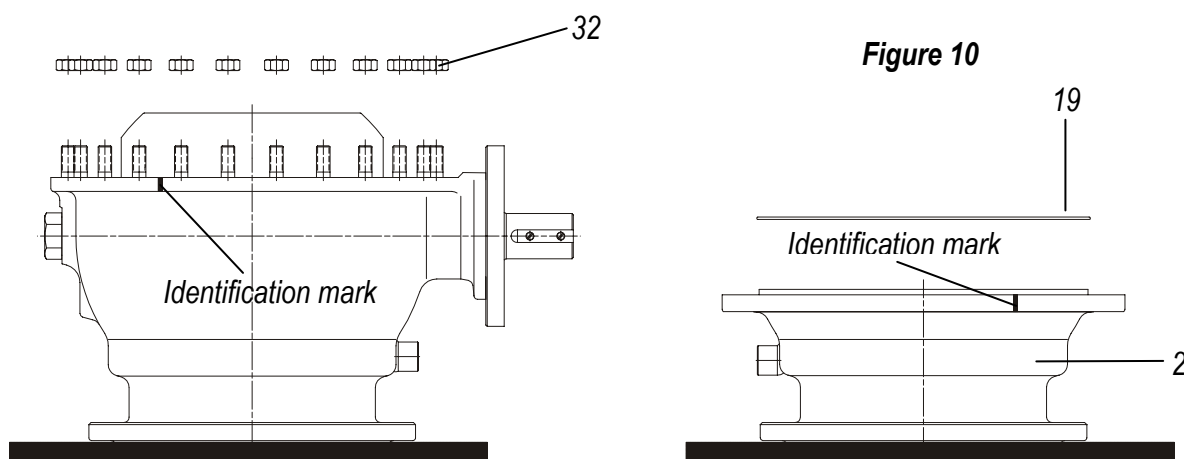

- Take off sealing ring (item 19)
- Screw hexagon head screws (item 35) out of bearing journal (item 5) remove gasket (item 14)
- Dismantle circlip (item 29) from ball hub, remove discs (item 12) to centre for height

**ATTENTION:** The same number of identically strong cushion joints must be used again during assembly.

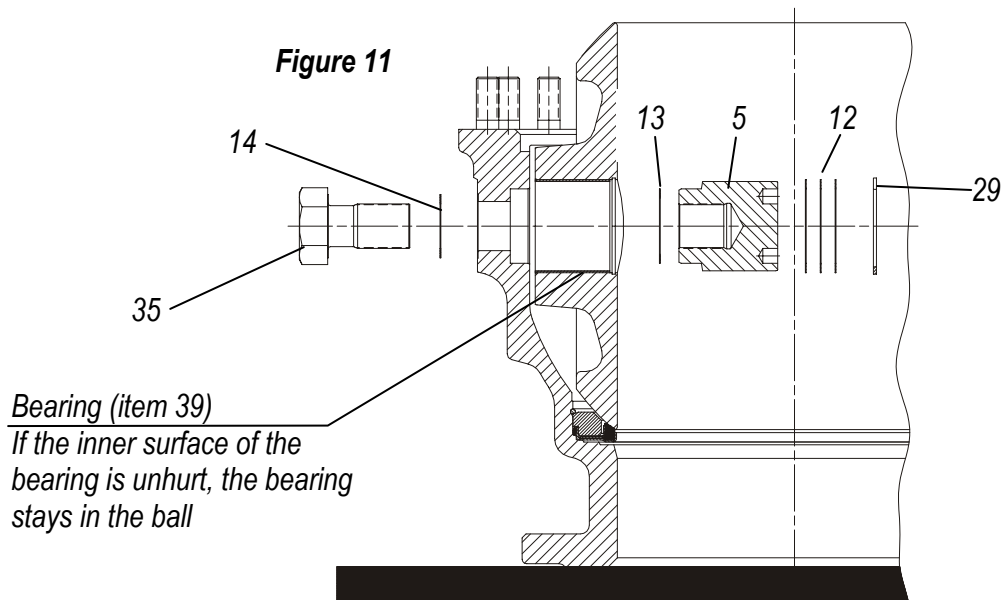

- Insert bearing journals (item 5) into the ball valve opening (knock out carefully), remove gasket (item 13)
- Dismantle assembly parts on the operating stem end, such as the cock handle, mechanical gearing, extensions, consoles, etc
- Unscrew mounting flange bolts (item 31) and take off flange (item 7) with sealing ring (item 17) over the shaft end. Remove cushion joints (item 16). If there is a locking screw (item 41) and seal which hold the bush insert lower part is present, the customer has to remove them first (item 42)

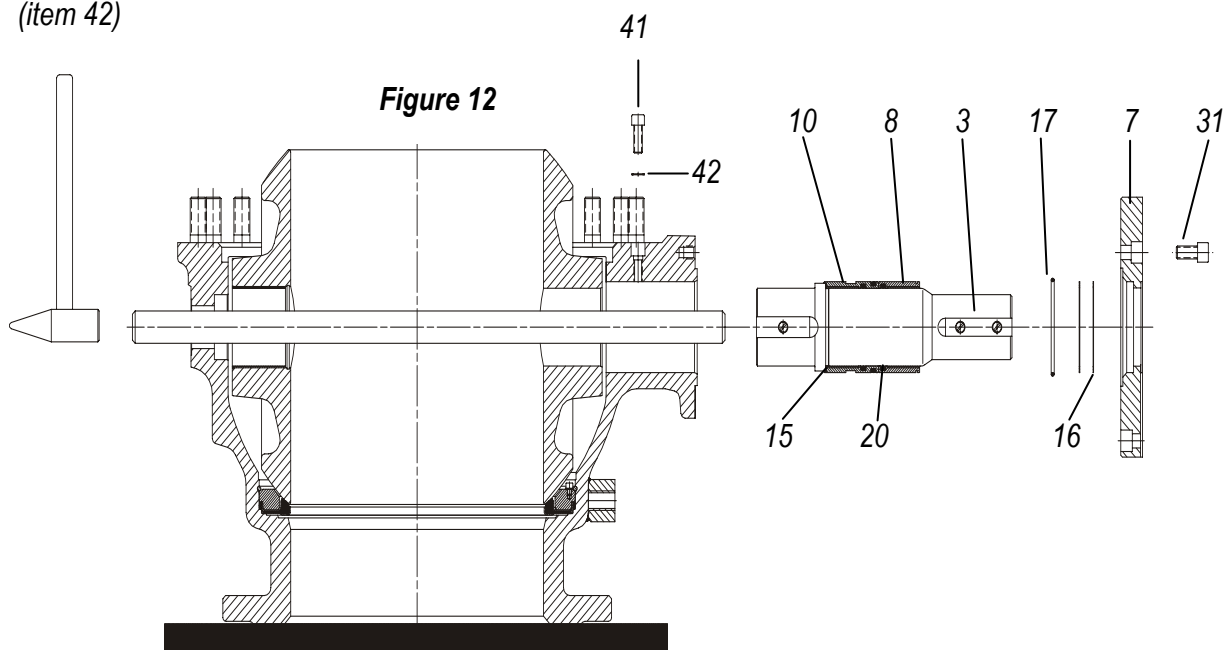

- Knock the operating stem (item 3) and bush inserts (items 8,10) carefully out of the body along with sealing rings and bearing bushes
- Turn the ball manually by 90°, lift it out of the body and place it on a suitable support

**Figure 13**

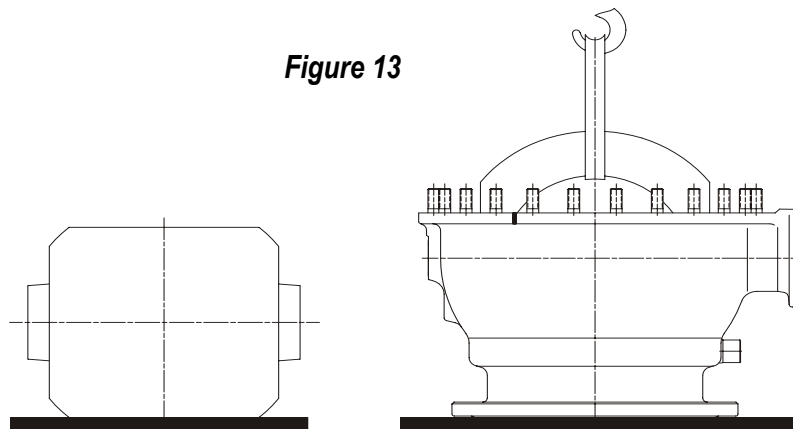

**Assembly of sealing element using body and connection piece**

- Screw fillister head screws (item 27) along with serrated lock washer (item 43) if present (starting in the year 1991) out of the back-up ring (item 24).
- The open ends of the wire ring have to be pressed together (item 23) and lifted out of the groove
- Insert two larger opposing screw drivers into the gap between the sealing element and body (connection piece), use it as a lever to press sealing element (item 22) and back-up ring (item 24) out of the turned groove. Take the remaining seals (items 18, 21) out of interior.

**Figure 14**

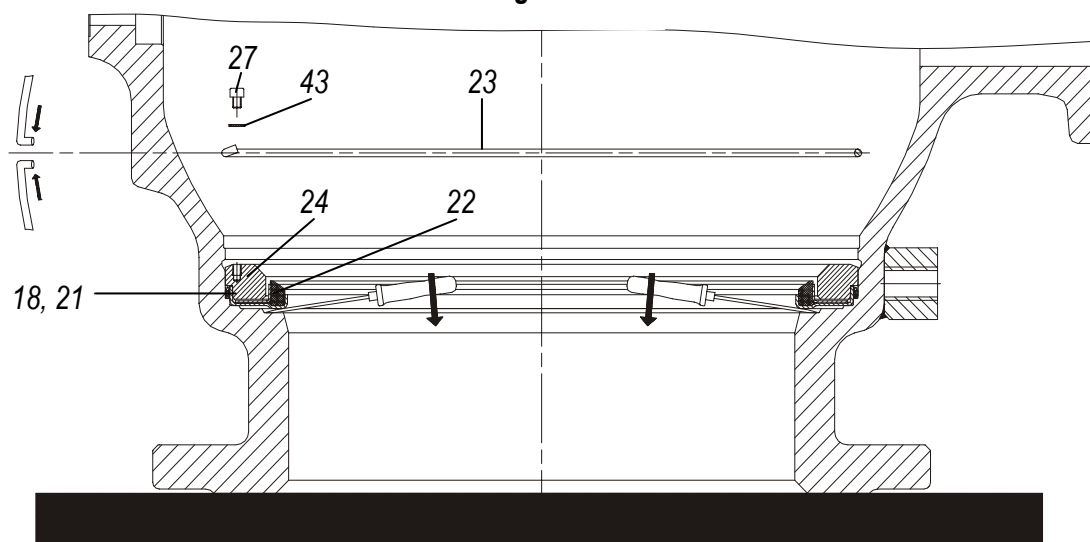

**ATTENTION:** All components particularly the seals and the sealing surfaces, are to be conscientiously checked before assembly, and replaced by new parts in the event of damage. Visible contamination on the machined locations must be cleaned. Cleaned components are to be provided with a uniformly thin layer of grease prior to installation.

**STANDARD lubrication chart:**

O-rings: Silicon grease OKS 01110, MOLYKOTE 55 M

other parts: Mobilplex 47

In special cases the lubricant prescribed while ordering must be used.

For example: **SYNTHESOL UG1** for hydrocarbons **AIRPRESS C 40 kp** for oxygen systems.

## ASSEMBLY

- The modular system makes it possible to fit the sealing elements with special sealing rings as requirements dictate. **All sealing elements are reassembled and ready to install!** Sealing elements are according to needs.

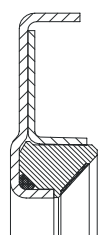

Metallic sealing elements for special requirements:

Applications in which the load carrying capacity of soft-sealing rings is overtaxed, e.g. for media having solid content, etc.

- Insert new sealing elements (item 22)
- Slip over sealing ring (item 18) on the periphery of the sealing elements and press down, put on U-sleeve (item 21) with closed facing up, gently pinch the open side and press into the groove.
- Insert back-up ring (item 24) and secure it with a wire ring (open wire ring end in the area of the bearing journal). The latter must lock into place in the snap ring groove by widening the open end to ensure a tight fit. Should it be difficult to bring the wire ring into its position, the sealing element has to be spring-mounted. Press down the back-up ring using two space blocks and a U-iron fragment, which is clamped down by two hexagon nuts.

Figure 15

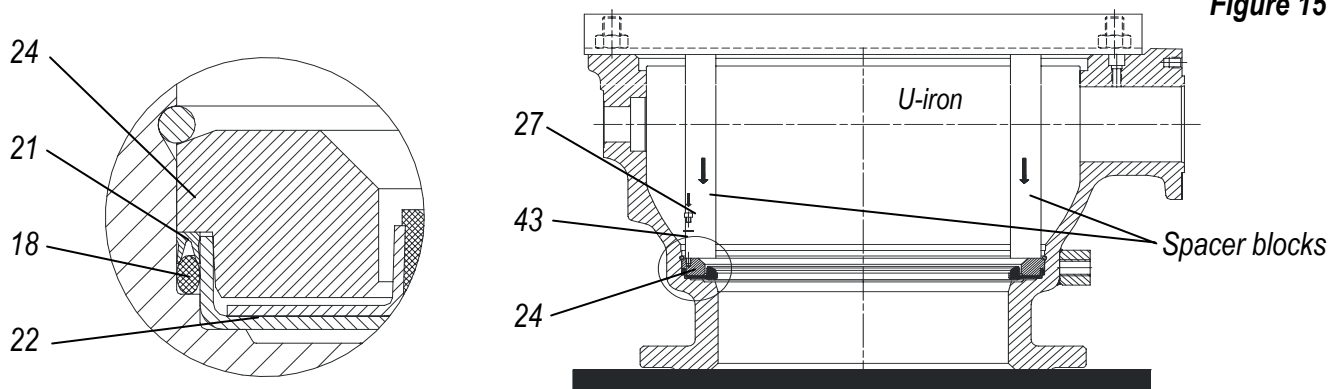

- Screw fillister head screws (item 27) with serrated lock washers (item 43) into the threaded holes of the back-up ring until tight
- Remove back-up ring assembly aid
- Lift ball in body (hub with feather key grooves on operating stem end) and place on sealing element

- Turn ball manually to OPEN setting
- Preassemble bush inserts (item 8,10) with all components (item 15,20,38) on operating stems, place feather keys (item 36) in existing grooves and screw down (item 34)
- Insert operating stem with components on the mounting flange end into body, and introduce ball unit collar sets on ball hub. Install seal (item 17) and cushion joints (item 16).
- Place on flange (item 7) in correct position and gasket down on body separated by block (item 31)
- Screw in locking screws (item 41) and seal (item 42) if present, and secure bush inserts, lower part.
- Place new degreased soft nickel gasket (item 13) into body groove, insert bearing journal (item 5) through ball hub, and screw hexagon screw (item 35) with new metallic gasket (item 14) into the bearing journal thread.
- The prestress of the sealing element might make it necessary to press down the ball, so that the bearing journal can be introduced into the body insertion point. Clamp down with mounting device in such a way that the location holes are aligned.

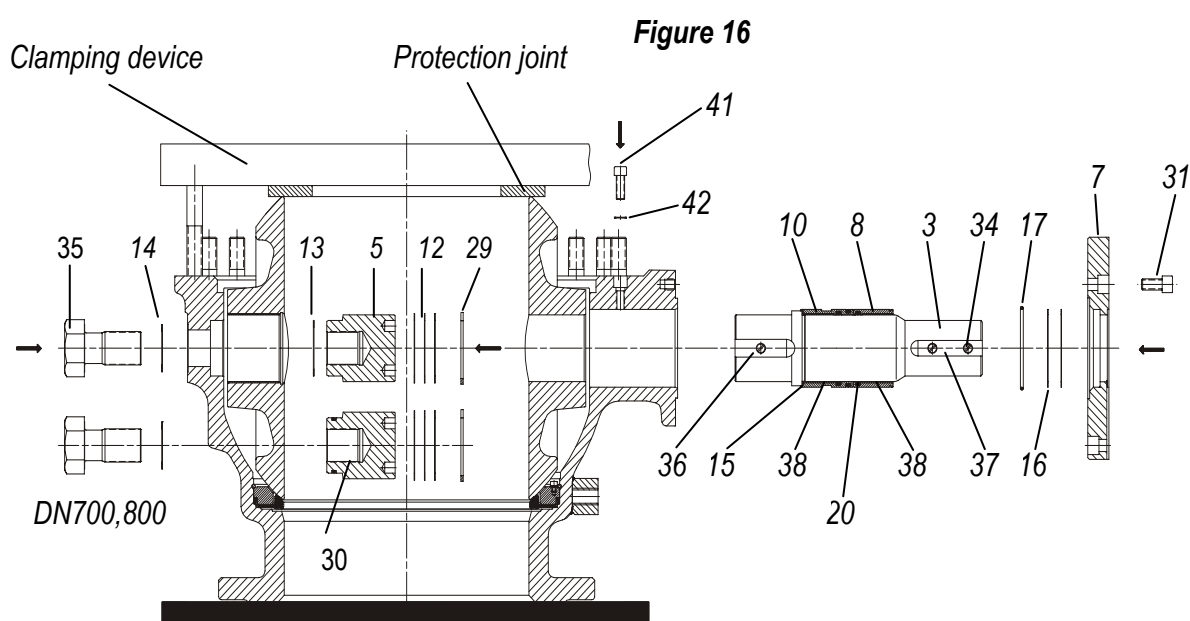

- Tighten bearing journal screw (item 35) with the prescribed torque (Table 2) (if necessary, counter-lock on the inside with two-hole keys).
- Take the same number of identically strong cushion joints (item 12) present during disassembly and place them on bearing journal. Fix the cushion joints into position using circlip (item 29), which must engage in the provided groove at the ball hub.  
No circlip is on hand for nominal balls widths DN 125, 150. The ball is concentrically adjusted in the sealing elements.
- Functional test
- Place connection piece (item 2) along with sealing ring (item 19) on the body in the marked position and let them lock into place in the centring shoulder
- Screw nuts (item 32) on projecting studs and tighten cross-wise with the indicated torque (Table 1)
- Assemble the parts for installation (cock handle, mechanical gearing, etc.)

**ATTENTION:** Turn ball valve TO RIGHT to close.

**ATTENTION:** If the ball is not properly aligned in its axial position or if the axial play is too high, (DN 200 – 400 max. 0,3 mm; DN 500 – 1000 max. 0,5 mm) then the cushion joints must be used to position them in the centre of the body.

Alignment between the ball valve opening and sealing element takes place in the OPEN setting, either visually or using a measuring instrument.

Figure 17

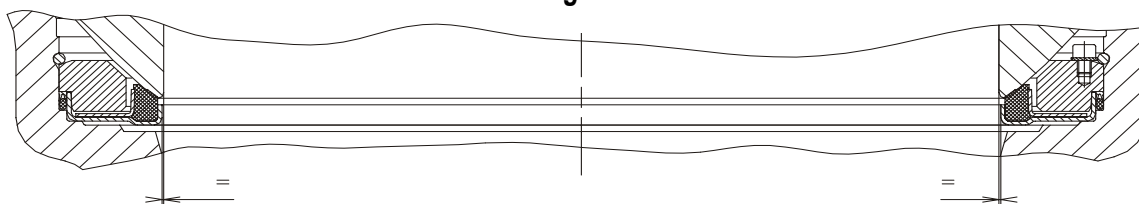

**a) Cushion joints (item 12) on the bearing journal**

- The space measured between the bearing journal and the lower edge of the circlip determines the height of the cushion joints.
- Set the cushion joints
- Set protection ring (item 29)
- Push the ball in direction of the journal pin to the present position.

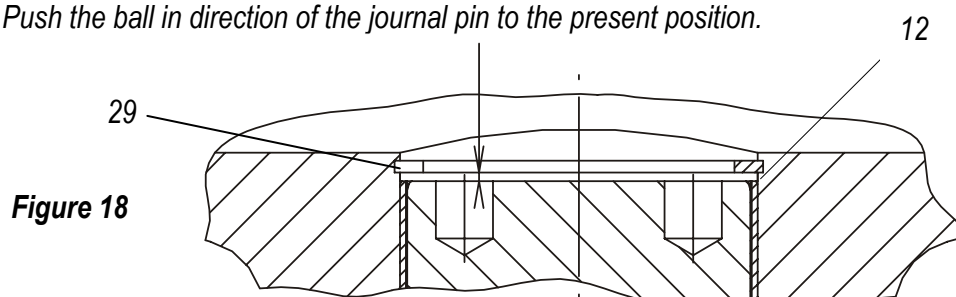

**b) Cushion joints (item 16) at head-flange**

- The projecting length from the bush insert over the body should be compared with the measured dept of recess for the bush insert on the flange.
- Measure difference minus 0,3 or 0,5 (required axial play) gives the height of the charging cushion joints.
- Mounting of flange (item 7)

Figure 19

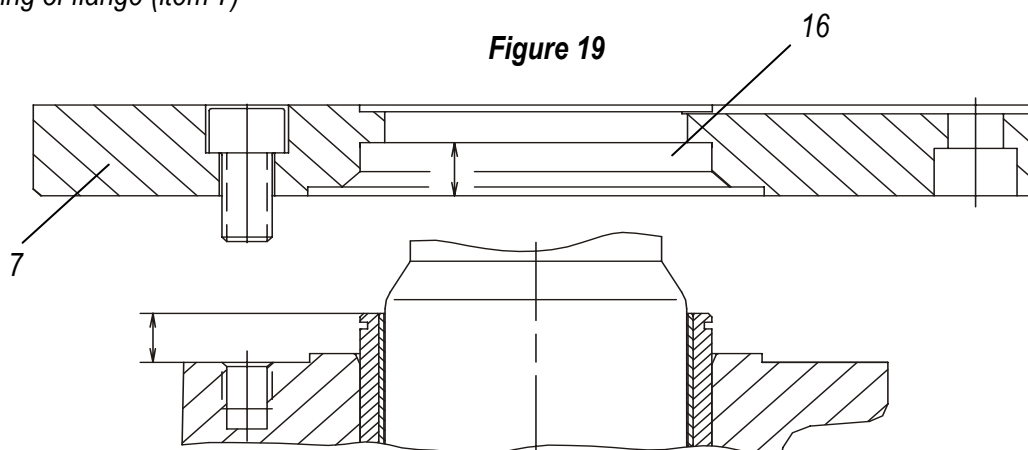

## INSTALLATION INSTRUCTIONS FOR ACTUATOR ASSEMBLY

### Preparation:

The actuator must be designed with a torque corresponding to the nominal width. The valves are to be set following a technical consultation (pressure, sealing material, media, etc.) with the manufacturer. The connecting parts must be fabricated in accordance with the size of the actuator.

Figure 20

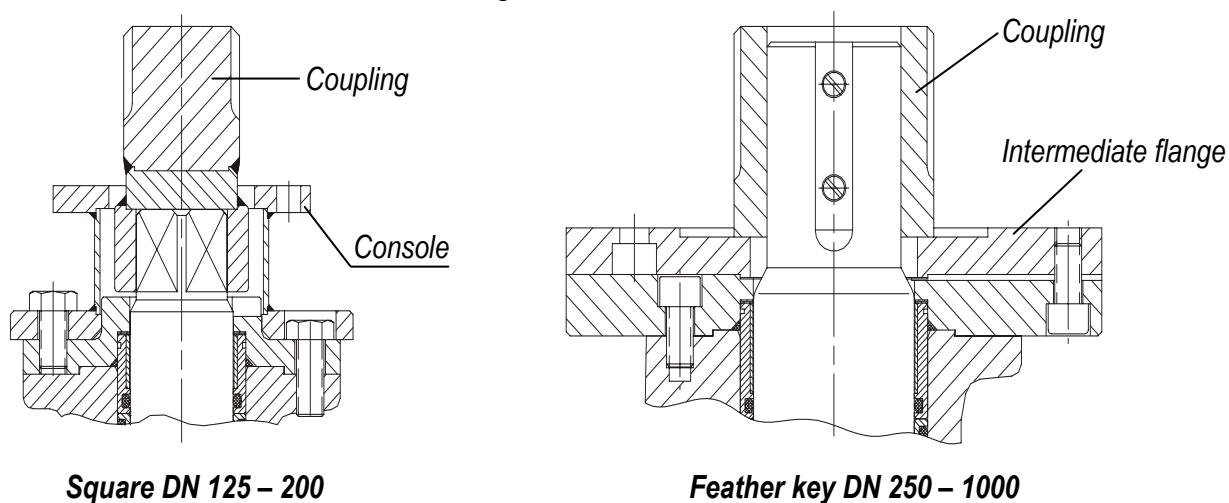

Actuator assembly work may also be done subsequently at any time without dismantling the valve fitting.

Standard mounting flange according to ISO 5211.

## ASSEMBLY

- Switch ball valve to OPEN setting
- Place on coupling piece
- Fasten on console or connecting flange to ball valve
- Place on actuator in correct position and screw down. Pin together, if necessary.

**ATTENTION:** Turn valve fitting to right to close.

Make sure that the 90° movement between its end settings ON and OFF is precisely maintained.

- Functional test

### Material codes for Klinger Ballostar – Ball valves

<b>Symbol</b>	<b>Body/connection piece</b>	<b>Internal parts</b>	<b>Colour of cock</b>
<b>III</b>	Grey cast iron	No non-ferrous metal parts	Grey RAL 7005
<b>VII</b>	Cast steel	Non-ferrous metal parts possible	Grey RAL 5015
<b>VIII</b>	Cast steel	No non-ferrous metal parts	Grey RAL 5015
<b>X</b>	Acid-proofed cast steel	Acid-proofed steel parts which have contact with the medium	Bright
<b>Xc</b>	Acid-proofed cast steel	All acid-proofed stainless steel parts	Bright

Major item of the material code is the basic material of body and connecting piece

#### used materials:

	<i>DIN material number</i>	<i>DIN token</i>	<i>EN material code.</i>	<i>EN token</i>
<b>Grey steel iron</b>	0.6025	GG-25	EN-JL1040	EN-GJL-250
<b>Cast steel</b>	1.0619	GS-C25	1.0619	GP240GH
<b>Acid-proofed cast steel</b>	1.4408	GX6CrNiMo18-10	1.4408	GX5CrNiMo19-11-2

Face to face dimensions, area of application etc. are configured in the catalogue

## PARTS LIST

Item	Spare parts	Components				Materials
		Wkz VII	Wkz VIII	X	Xc	
1	Body	1.0619.01	1.0619.01	1.4408	1.4408	
2	Connection piece	1.0619.01	1.0619.01	1.4408	1.4408	
3	Operating stem	1.4104	1.4104	1.4401	1.4401	
4	Ball	0.7043FeCr30	0.7043 FeCr30	1.4408	1.4408	
5	Bearing journal	1.4101	1.4104	1.4401	1.4401	
7	Flange	1.0116	1.0116	1.4401	1.4401	
8	Bush insert – UP	1.0580phrf	1.0580phrf	1.4401w.n.	1.4401w.n.	
10	Bush insert – LP	1.0580phrf	1.0580phrf	1.4401w.n.	1.4401w.n.	
12	Disk	1.4101	1.4101	1.4401	1.4401	
13	Gasket	Soft nickel				*
14	Gasket	Soft nickel				*
15	Cushion joint	KFC-25				*
16	Cushion joint	K-Sil				*
17	O-ring	*)				*
18	O-ring	*)				*
19	O-ring	**)				*
20	O-ring	*)				*
21	U-sleeve	KFC-25				*
22	Sealing element	VII-KFC	VII-KFC	X-KFC	X-KFC	*
23	Wire ring	1.4401.07				
24	Back-up ring	0.6020phrf	0.6020phrf	1.4408	1.4408	
25	O-ring	*)				*
26	Rating plate	1.4305				
27	Fillister head screw	A 4				
28	Grooved drive stud	A 2				
29	Circlip	1.4310				
30	O-ring	*)				*
31	Fillister head screw	10.9	10.9	10.9	A 4	
32	Hexagon nut	8	8	8 E2P	A 4-70	
33	Stud	8.8	8.8	8.8 E2P	A 4-70	
34	Fillister head screw	A 4	A 4	A 4	A 4	
35	Hexagon head screw	1.1181	1.1181	1.1181	1.4305	
36	Feather key	1.0052.07	1.0052.07	1.4401	1.4401	
37	Feather key	1.0052.07	1.0052.07	1.0052.07	1.4401	
38	Bearing bush	St/Bz/Flon	AISI 316L/PTFE 90			*
39	Bearing bush	St/Bz/Flon	AISI 316L/PTFE 90			*
40	Bearing bush	St/Bz/Flon	AISI 316L/PTFE 90			*
41	Locking screw	10.8		A4		
42	Gasket	copper				

\*) O-Ring compound in accordance to the service conditions

Standard grade:                      Aflas (AF)    FEPM  
Steam and hot water design (WI)              Fluoraz            799G

\*\*\*) Gasket in accordance to the service conditions

Standard grade:                      Aflas (AF)    FEPM  
Steam and hot water design (WI)              Spiral wounded gasket (Graphit/1.4541)

## SPARE PARTS LIST

**Ballostar - ball valve DN 150/125 PN25/40**

Item	Pce s	Name components	Materials by Wkz				Dimension
			VII	VIII	X	Xc	
13	1	Gasket	Soft nickel				35/43x1 KLN 1
14	1	Gasket	Soft nickel				26/36x1 KLN 1
15	1	Cushion joints	KFC-25				45/54x1 KLN 2435/1
16	3	Cushion joints	K-Sil				46/58x0,5 46/58x0,3
17	1	O-ring	*)				ARP 228 (56,74x3,53)
18	2	O-ring	*)				ARP 260 (164,69x3,53)
19	1	O-ring/spiral wound gasket	**)				ARP266 (202,79x3,53)/Ø222,5x206x4,5
20	1	O-ring	*)				ARP 328 (46,99x5,33)
21	2	U-sleeve	KFC-25				125 KLN 2416
22	2	Sealing element	VIII/KFC		X-KFC		125 KLN 2414/2 ***)
25	2	O-ring	*)				equal to pos.20
38	2	Bearing bush	St/Bz/Flon				MB 4520 DU KLN 2438/1
					AISI 316 L/PTFE 90		PI 4519 KLN 2438/2
39	1	Bearing bush	St/Bz/Flon				MB 5030 DU KLN 2438/1
					AISI 316 L/PTFE 90		PI 5029 KLN 2438/2

\*) O-Ring compound in accordance to the service conditions

Standard grade: Aflas (AF) FEPM

Steam and hot water design (WI) Fluoraz 799G

\*\*\*) Gasket in accordance to the service conditions

Standard grade: Aflas (AF) FEPM

Steam and hot water design (WI) Spiral wounded gasket (Graphit/1.4541)

\*\*\*) sealing elements

in accordance to specification by special design  
equipped with metal sealing ring

In the interest of technical progress, designs and dimensions are subject of modification





















