



Steamix™

Steam & Water Hose Station and Mixing Valve Installation and Maintenance

This Steamix Hose Station/Mixing Unit has been supplied for this application based upon information provided to Armstrong at the time the order was placed.

In the event that this information was inaccurate or has since changed, product performance and user safety may be compromised.

This Steamix Hose Station/Mixing Unit is supplied to generate hot water by mixing steam and water at a single point of use within specific parameters for industrial applications only.

This Steamix Hose Station/Mixing Unit is not designed and should never be installed to deliver hot water for hygiene or sanitary applications (people washing).

This Steamix Hose Station/Mixing Unit is not designed and should never be installed to deliver tepid water to Emergency Fixtures.

This I & M covers the Steamix Model Numbers identified on page 3.

Specific model numbers can be determined calling our customer Hot Line at 1-888-HOT-HOSE and referencing the serial number.

Model No. _____

Serial No. _____

Ship Date: _____

U.S. Patent: 4,834,130

Warning

Steamix Hose Stations and Mixing Units are specifically designed to heat water to extremely hot temperatures. Failure to observe these warnings could result in serious injury, including severe burns from scalding water and flash steam.

1. **Read and understand all instructions before operating this equipment.**
2. Always check the flow direction of the valve and nozzle before each use.
3. Always point the nozzle in the direction of the arrow.
4. Never point the nozzle or valve at yourself or another person.
5. Always keep hands and fingers clear of the nozzle outlet, mixing valve body and steam inlet.
6. Always check and be aware of the last set position of the temperature control handle before use. The Mixing Valve will automatically rise to the previous temperature setting unless the temperature control handle is returned to its seating position by rotating 'clockwise' to stop.
7. Always check that the Maximum Temperature Lockout feature has not been tampered with or mis-adjusted before use.
8. Always wear water and heat protective gloves, garments, face protection, and safety glasses.
9. Only to be operated by persons trained in this equipment's use and safety.
10. Always return the hose to its holder after use.
11. Always release the water pressure in the hose after use.
12. Always close (shut off) the inlet supply controls after use.
13. Only use this equipment for its intended industrial purpose: washdowns, vessel filling, and process applications.
14. **Do Not** substitute any component part on this assembly.
15. Use only performance matched parts for replacement from Armstrong Hot Water Group.
16. Use of incorrect parts could cause serious personal injury.
17. **Do Not** use attachments not authorized by the manufacturer. They may cause fire, electrical shock, or injury.
18. **Do Not** operate the equipment if it malfunctions, is dropped, or has been damaged in any manner.
19. **Do Not** operate this equipment if its hose is ripped or damaged in any manner.
20. Make **certain** that this equipment is properly installed before use.
21. **Do Not**, under any circumstances, use this product to supply hot water for human showering, bathing, or hand washing applications.
22. This product is unsuitable for use to supply water at any temperature for drench showers, eye wash stations or other emergency equipment.
23. If you have questions, consult this manual or call our Customer Hotline at (888) HOT-HOSE.

Introduction

Steamix[®] is a registered trademark of Armstrong Hot Water Group, a division of Armstrong International, Inc. Steamix is a brand of patented steam/water mixing valves and hose stations.

For the purposes of this product manual, the model number STEAMIX 203 refers to the Mixing Unit featured on the Steamix Hose Station.

Steamix 203 is ideal for vessel filling, hose down and similar process applications. Steamix is available in multiple derivative assembly configurations and subsequent model numbers.

This Installation & Maintenance Guide covers the following Steamix Model Numbers along with the Nickel Plated Premium version which is identified with suffix iSi. Contact us Toll Free at 1-888-HOT-HOSE to request a specific drawing.

Model Number	Drawing Number Standard	Drawing Number Premium
Steamix VE-M	CDLW-1114	—
Steamix VE-H	CDLW-1121	—
Steamix 2030H	CDLW-1116	CDLW-1117
Steamix 2031	CDLW-1031	CDLW-1054
Steamix 2032	CDLW-1032	CDLW-1055
Steamix 2033	CDLW-1033	CDLW-1056

Note: CDLW Drawings will denote current production model as identified and may not be relevant for historical identification purposes

This Installation and Maintenance Guide covers the following Steamix production generations.

Classic 1990-1999 Serial Numbers A1000-A10000

Millennium 1999-2003 Serial Numbers A-L10000 — A-L13300

Infinity 2004 to present Serial Numbers A-L13300 and Above

Product modifications and non-compatible replacement parts make Steamix generation identification mandatory prior to valve servicing or spare parts ordering. Refer to Page 14 or call our Customer Hot Line 1-888-HOT-HOSE for Steamix identification indicators.

Warning: This product is designed to heat water for industrial washdown, vessel filling and process applications only. Access to extreme water temperatures and flash steam is a possibility. To avoid serious injury use extreme care and wear protective gloves, garments and safety glasses at all times.

Operational Precautions / Safety Warnings

1. It is recommended that strainers always be installed (even if not supplied with unit) before Steamix 203 downstream of all other components including check valves.
2. **Do not** use this product with superheated steam. Failure to heed this warning may result in serious injury.
3. This product is designed strictly for Industrial Processes and Hose Down applications. **Do not use for safety shower/eye wash stations, hand-washing or any other type of personal hygiene.**
4. **Do not** leave the hose under pressure. Failure to follow this recommendation may lead to premature hose degradation and possible rupture.
5. The gland seal may have relaxed during shipment. Before use, firmly tighten the two gland screws equally using the 5/32" Allen key supplied.
6. Install steam rated inlet check valves on both steam and water supplies to prevent backflow through the mixing valve. Check valves will assist in the prevention of a cross connection in the event that Steamix flow controls are left open and an outlet flow control (spray nozzle) is closed. In addition, under certain circumstances, backflow may create a pressure differential across the diaphragm great enough to allow the poppet valve to open and steam to flow. Without inlet flow being present, this becomes a potentially dangerous condition.
7. Steamix 203 uses the supply steam so efficiently that it is possible to set the mixing valve to deliver boiling water that may flash to steam upon reaching the atmosphere at the valve outlet. This phenomenon should not be mistaken for valve failure or the passing of pressurized "live" supply steam.
8. **Do not** use petroleum-based lubricants on this product.
9. Use **only** Silicone-based lubricants.

Warning: This product is designed to heat water for industrial washdown, vessel filling and process applications only. Access to extreme water temperatures and flash steam is a possibility. To avoid serious injury use extreme care and wear protective gloves, garments and safety glasses at all times.

Theory of Operation

Steamix 203 produces hot water by mixing steam with cold water. The hot water temperature is variable from cold to almost boiling by rotating the temperature regulating lever counter-clockwise. If desired, the temperature can be locked at a pre-selected level by removing the temperature regulating lever and further secured by installing Part No. 042 tamper resistant locking Set. (See page 22.)

Inlet water pressure activates the mixing valve allowing steam to heat the water. The valve requires a minimum inlet water pressure of 20 psig (1.4 bar) to open the steam inlet. This method of operation provides a built-in safety feature where the mixing valve automatically shuts off the steam supply when a water supply failure or a pressure reduction below 20 psi (1.4 bar) occurs.

The following diagrams illustrate the mixing valve's method of operation.

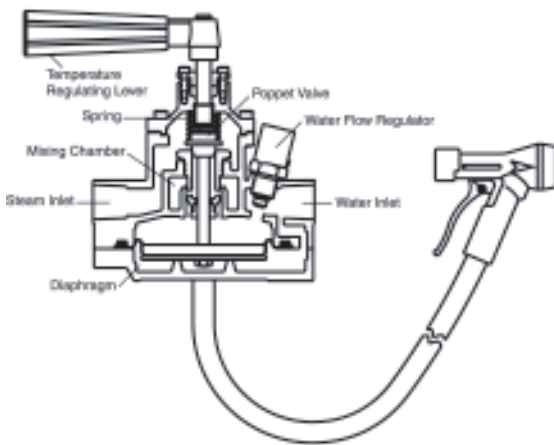

Figure 5-1. With the outlet closed and no flow, the water pressures on either side of the diaphragm are equal. This allows the spring to hold the poppet valve on its seat thereby preventing steam flow.

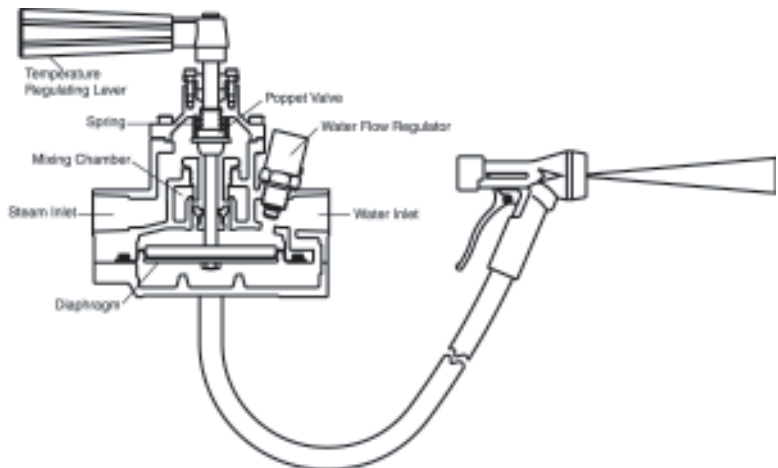

Figure 5-2. Opening the outlet allows water to begin to flow. When a minimum differential pressure of 7 psi (.5 bar) develops across the diaphragm*, the diaphragm lifts from its resting position and pushes the poppet valve off the steam seat allowing steam to flow. By allowing steam to flow only when inlet water flow is present, the operator is protected from accidental exposure to live steam should the water supply fail. The poppet valve is resisted by the temperature control lever which allows more or less steam into the mix for higher or lower outlet temperatures as adjusted.

*a minimum of 20 psi (14.4 bar) water pressure is required to lift the diaphragm.

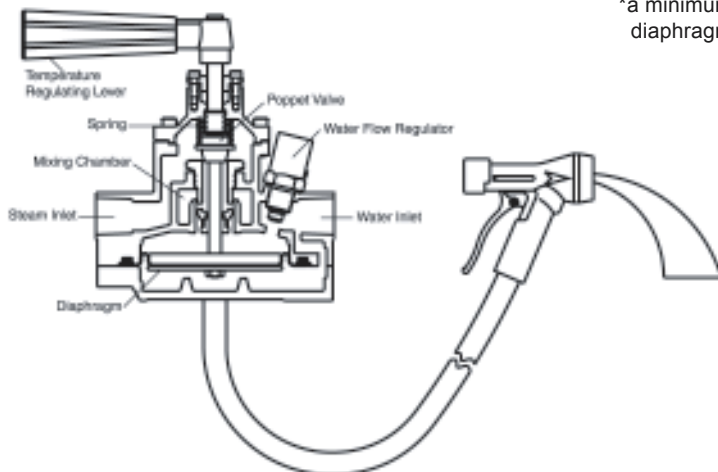

Figure 5-3. Closing the outlet valve increases back pressure. When the differential pressure across the diaphragm becomes less than 7 psi (.5 bar) or the water pressure is reduced below 20 psi (1.4 bar) the spring pushes the poppet valve closed, shutting off the steam flow and the diaphragm returns to its resting position.

Temperature /Pressure

- Minimum Steam / Water pressure: 20 psig (1.4 bar)
- Maximum Steam / Water pressure: 150 psig (10 bar)

The STEAMIX 203 produces hot water at its outlet by mixing steam with cold water. This process uses the direct relationship:

- the greater the steam pressure, the greater the temperature rise ($T_2 - T_1$) of the outlet water
- the greater the steam pressure, the greater the flow rate obtained on reaching the desired operating temperature.

In situations where only very low steam pressure is available the mixing valve will still function properly but a large reduction in the outlet flow rate will occur.

Optimum performance occurs when steam is in the 50 - 75 psig (3.3-5 bar) range and the water pressure is 50-75 psig (3.3-5 bar).

Steam supply lines **must** be adequately sized to deliver a sufficient **volume** of steam.

Water supply lines **must** be adequately sized to deliver a sufficient **volume** of water.

Do not use this product with superheated steam. Failure to heed this warning may result in serious injury.

Steam Consumption

To approximate the amount of steam consumed during operation proceed as follows:

1. Measure, calculate or approximate the outlet hot water flow from Steamix. Review the flow charts on Page 7 but be sure to acknowledge the presence of any outlet fitting such as a Spray Nozzle* at the end of a Washdown Hose in a Hose Station application.

*For approximation purposes use 7 GPM to rate the Spray Nozzle.

2. Note the inlet cold water temperature (T1) and desired outlet hot water temperature (T2) and establish the Temperature Rise based upon the differential (T2-T1).
3. Apply the following formula.

Lbs per Hour = GPM/2 X (T2-T1)

Warning: This product is designed to heat water for industrial washdown, vessel filling and process applications only. Access to extreme water temperatures and flash steam is a possibility. To avoid serious injury use extreme care and wear protective gloves, garments and safety glasses at all times.

Flow Rates / Temperature

The following capacity charts indicate Steamix 203 flow rates at steam and water pressures commonly available in the average manufacturing plant.

The mixing valve can handle a wide diversity of pressures and temperatures. The three typical outlet temperatures shown in the tables demonstrate the mixing valves flow rate at:

1. "User Safe" temperature (approximately 120 °F/48 °C).
2. "Hot Hose Down" temperature (approximately 150-160°F/65°-71°C).
3. "Common Bacteria Kill" temperature (approximately 180°F/82°C) .

The phrase "Common Bacteria Kill" is not meant to imply sterilization capability. However, Steamix 203's design allows it to handle the higher temperatures required in Food, Beverage, and Pharmaceutical Facilities.

55°F (31°C) Temperature Rise					
Water \ Steam	20 (1.4)	45 (3)	75 (5)	100 (7)	psi (bar)
22 psi (1.5 bar)	9.6 (26.1)	10.2 (38.6)	10.2 (38.6)	10.2 (38.6)	gal/min (l/min)
45 psi (3 bar)	9.6 (26.1)	13.2 (49.9)	13.2 (49.9)	13.2 (49.9)	gal/min (l/min)
60 psi (4 bar)	9.6 (26.1)	13.8 (52.2)	15.7 (59.4)	15.7 (59.4)	gal/min (l/min)

100°F (56°C) Temperature Rise					
Water \ Steam	20 (1.4)	45 (3)	75 (5)	100 (7)	psi (bar)
22 psi (1.5 bar)	3.6 (13.6)	6.9 (26.1)	8.3 (31.4)	8.5 (32.1)	gal/min (l/min)
45 psi (3 bar)	3.6 (13.6)	6.9 (26.1)	9.4 (35.5)	9.9 (37.4)	gal/min (l/min)
60 psi (4 bar)	3.6 (13.6)	6.9 (26.1)	9.4 (35.5)	10.5 (39.7)	gal/min (l/min)

135°F (73°C) Temperature Rise					
Water \ Steam	20 (1.4)	45 (3)	75 (5)	100 (7)	psi (bar)
22 psi (1.5 bar)	2.5 (9.4)	5.0 (18.9)	6.6 (24.9)	7.2 (27.2)	gal/min (l/min)
45 psi (3 bar)	2.5 (9.4)	5.0 (18.9)	7.2 (27.2)	8.0 (30.2)	gal/min (l/min)
60 psi (4 bar)	2.5 (9.4)	5.0 (18.9)	7.2 (27.2)	8.0 (30.2)	gal/min (l/min)

Note: Low inlet pressures will significantly reduce outlet flow. Consult factory to determine application suitability.

Warning: This product is designed to heat water for industrial washdown, vessel filling and process applications only. Access to extreme water temperatures and flash steam is a possibility. To avoid serious injury use extreme care and wear protective gloves, garments and safety glasses at all times.

Installation

Installation of Steamix 203 Mixing Valves and Hose Stations must comply with the relevant Federal, State and Local Sanitary, Construction, and Plumbing Code requirements.

1. When installing the mixing valve and associated fittings, position the valve to permit easy access for adjustment and servicing procedures.
2. Steamix Hose Stations and Mixing Units are supplied pre-assembled and pressure tested. All components are precision fitted by professional fully trained assemblers using an anaerobic thread sealant. Failure to "Hold Back" when piping to the unit will cause component shift which will compromise the assembly and may lead to leakage.
3. Install shut off valves on each inlet. Install shut off valves in a location which discourages tampering by the operator. Temperature and Flow must be controlled strictly at the Mixing Unit/Hose Station.
4. Install check valves on both inlets to prevent backflow through the mixing valve. Check valves will assist in the prevention of a cross connection in the event that Steamix flow controls are left open and an outlet flow control (spray nozzle) is closed. In addition, under certain circumstances, backflow may create a pressure differential across the diaphragm great enough to allow the poppet valve to open and steam to flow. Without inlet flow being present, this becomes a potentially dangerous condition.
5. Install unions on each inlet supply (factory supplied on specific models).
6. If the unit is to be hard piped from its outlet, then install a union at the outlet to facilitate servicing.
7. If not supplied by the Armstrong Hot Water Group, install a thermometer in the outlet pipe work for ease of temperature monitoring and adjustment.
8. Secure the mixing valve or hose station to a wall or column using the pre-drilled mounting plate provided for this purpose. The weight of the unit should not bear directly on the pipework.
9. Hose Stations include a rugged stainless steel hose carrier and backplate pre-drilled to facilitate anchoring.

Back Flow/Back Siphonage Prevention

In addition to check valves, the installation must comply with Local and State Codes, as well as the requirements of any Agency responsible for the inspection of, or compliance with Federal Regulations relating to your industry. This may include the installation of single or double action Back Flow Preventer and/or Vacuum Breakers.

Plumbing Recommendations

1. Always install strainers (even if not supplied with unit) immediately before Steamix 203 and down-stream of all other components including Check Valves. Install strainers with the arrows pointing towards the mixing valve when placed in horizontal or vertical supplies so that the strainer screen traps debris.
2. If widely fluctuating steam pressure is a common occurrence, a pressure regulator set to the lowest pressure encountered should be installed a minimum of six feet upstream from the mixing valve.
3. It is recommended a steam trap be installed on the steam supply piping upstream of Steamix 203 to evacuate or return the condensate. Trap should be installed at least 6 feet away but no greater than 15 feet away from the inlet of Steamix 203 where possible.
4. Inlet check valves.
5. Unions.

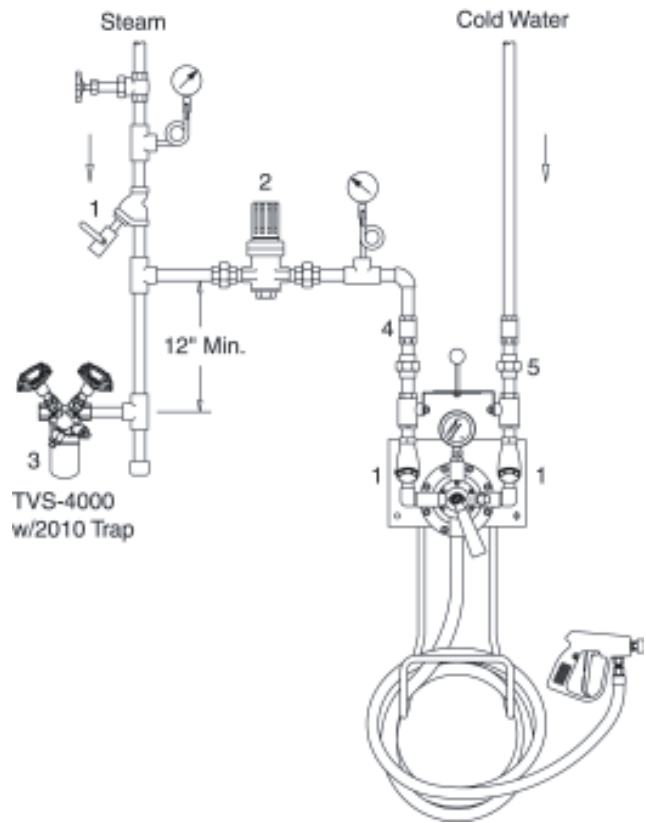

Start-Up Procedures

Prior to operating the valve, the outlet temperature must first be set within the required operating parameters as specified by plant management.

The available temperature range of the mixing valve is from ambient inlet water temperature to almost boiling. To set the mixing valve to the required temperature:

1. Turn the temperature regulating lever clockwise as far as it will go to close the steam inlet. (This may take several revolutions.)
2. Remove the water flow regulator locking cap using a 3/32" Hex Key to loosen the set screw located at the base of the cap. Fully open the cold water regulator by turning it counter-clockwise. The mixing valve is now in the full cold position.
3. Open the inlet flow control valve(s) and spray nozzle (if installed) so that maximum flow is achieved.
4. Turn the temperature regulating lever counter-clockwise until the desired temperature is obtained.
5. If the desired temperature is not reached when the temperature control lever is fully open, turn the water flow **regulator** clockwise until the required temperature is achieved.
6. Replace the water flow regulator locking cap.
7. The mixing valve is now set so that it can be adjusted from its maximum temperature to cold by moving only the temperature regulating lever.

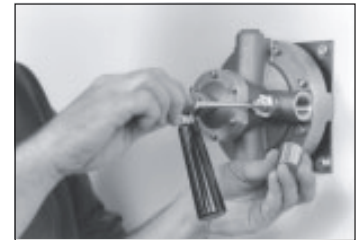

Most wash down procedures benefit from the operator's ability to vary the temperature as required. However, the temperature regulating lever can be removed and/or a tamper resistant "Lock Set" (optionally available part # 042) may be installed to prevent further temperature adjustment.

Instruct all operators not to tamper with the water flow restrictor.

For further details on #042 tamper resistant lock set turn to page 22.

Operating Procedures

The Steamix 203 uses the supply steam so efficiently that it is possible to set the mixing valve to deliver boiling water that may flash to steam upon reaching the atmosphere at the valve outlet. This phenomenon should not be mistaken for valve failure or the passing of pressurized "live" supply steam.

Daily Operation

1. Instruct all operators on basic safety procedures.
2. **Do Not** select a higher outlet temperature than required for process or wash down water. Using water that is too hot for the application is unsafe, wastes energy and may lead to inefficient clean-up.
3. Always shut off steam/water flow at the tandem valves.
4. **Do Not** leave the outlet hose under pressure. Bleed pressure by opening the outlet hose nozzle briefly.
5. Check the inlet supply shut-offs regularly.
6. Report any malfunction immediately to appropriate maintenance personnel.

Safety Check

1. Set the mixing valve for normal operation.
2. Start outlet water flowing.
3. Shut-off a remote inlet water supply stop valve.
4. Outlet water flow should cease immediately without any live pressurized supply steam being passed from the mixing valve.
5. If live steam is passed during the test **do not** use valve or hose station. Initiate maintenance procedures immediately.

Note: Testing of the intrinsic safety steam shut-off feature on a shift or daily basis does not degrade the unit.

Warning: This product is designed to heat water for industrial washdown, vessel filling and process applications only. Access to extreme water temperatures and flash steam is a possibility. To avoid serious injury use extreme care and wear protective gloves, garments and safety glasses at all times.

Diaphragm Performance and Durability

Steamix 203 operates on a pressure actuated diaphragm principle as discussed on page 5 of this manual.

A specially designed double-coated elastomer, high performance diaphragm has been custom designed for this application based upon extensive research and laboratory and field-testing.

Diaphragm Service Life

A chronological operational service life of a diaphragm is virtually impossible to specify due to the wide diversity of field application, inlet steam and water pressure and outlet flow temperature which Steamix experiences.

Steamix diaphragms are continuously cycle tested at our state of the art test facility in Three Rivers, MI and the diaphragms must be able to exceed 50,000 field simulated operational cycles at the maximum steam pressure rating of 150 psi. In real terms that equates to approximately 50 wash down cycles every day for three years.

Some diaphragms last longer (we have on record installations still fully operational at 12 years and counting), some do not last as long, which is why we offer a full replacement two-year warranty.

Safety

A diaphragm is a mechanical component in a mechanically operated product. All mechanical products have the potential to fail at some point in their service life. Steamix is the only product supplied for this application, which we are aware, that will fail to cold water flow in the event that its primary operating component (diaphragm) experiences failure.

Tips for Ensuring Long Diaphragm Service Life

1. **Cool Down:** Do not use a spray nozzle as a long-term flow control device. Turn the Steamix off at its inlet flow control when it is not in use and let the valve cool. It's good for the nozzle, it's good for the hose, it's good for the diaphragm.
2. **Steam Quality:** Maintain your steam system efficiently and watch the condensate chemistry. Highly acidic carbonic acid is not good anywhere in the system and the diaphragm is no different.
3. **Trap:** Trap the steam line feeding the Steamix effectively. Compounding large quantities of acidic condensate with water hammer and pressure shocks can cause all sorts of problems and again the diaphragm can suffer. By maintaining a reasonable distance (we suggest 6 feet) between the steam trap and Steamix, the cooled condensate in the pipework between the steam trap and Steamix will assist with Tip #1.
4. **Back Pressure:** Keep an eye on the pressure loss ratio discussed on page 12 of this Product Manual. High back pressures combined with diverse inlet pressures make the Steamix work extra hard and additional stress is placed upon the diaphragm.
5. **Keep it Low:** Steamix is rated for use with up to 150 psi steam. However, the outlet flow rate and temperature rise does not improve dramatically beyond 100 psi steam. In other words, we do not need steam pressures higher than 100 psi for effective, high temperature washdown. When possible, lower the inlet steam pressure to 100 psi or below. Tests have shown us that the extra 30 degrees or so which 150 psi steam gives you can really intensify temperature related fatigue on the diaphragm and seals within Steamix. Optimum performance pressures are noted on Page 6 of this manual.

Pressure and Pressure Loss Ratio

Minimum and Maximum Pressures

The minimum inlet pressures are:

- Water - 20 psig (1.4 bar)
- Steam - 20 psig (1.4 bar)

Note: Low inlet pressures will significantly reduce outlet flow.

The maximum static pressures are:

- Water - 150 psig (10 bar)
- Steam - 150 psig (10 bar)

Pressure Loss Ratios:

- Maximum pressure loss across the mixing valve (inlet to outlet): 60 psi (4 bar)
- Minimum pressure loss across the mixing valve (inlet to outlet): 7 psi (.4 bar)
- Maximum pressure loss ratio is 10:1 in favor of either supply.
- Pressure Loss Ratio (PLR) is the ratio of steam and cold water supply pressures minus the back pressure caused by the outlet fittings and additional pipework, hose, or nozzle.

Example:

If the back pressure developed at the valve outlet was 45 psi (3 bar) and the steam pressure is 100 psi (6.6 bar) with a water pressure of 50 psi (3.3 bar) the calculation for PLR would be:

$$100 - 45 = 55 \text{ psi and } 50 - 45 = 5 \text{ psi}$$

Thus, the pressure loss ratio is: 55: 5 or 11:1.*

$$6.6 \text{ bar} - 3 \text{ bar} = 3.6 \text{ bar and } 3.3 \text{ bar} - 3 \text{ bar} = .3 \text{ bar}$$

Thus, the pressure loss ratio is: 55: 5 or 11:1.*

**This unit will not operate effectively.*

Do not confuse the Pressure Loss Ratio with the Inlet Pressure Differential Ratio, which is the ratio of inlet pressures only (100:50 or 2:1) and does not take into account the back pressure.

For optimum performance, keep any restriction at the valve outlet to a minimum.

Tips:

1. The shorter the hose and minimal kinks the better the mixing valve's performance.
2. Use the least restrictive nozzle obtainable.
3. Ensure that pressure or temperature gauges do not restrict the mixed water flow.
4. The lower the pressure loss on the mixing valve or hose station outlet, the greater the flow rate and cleaning power.
5. Excessive back pressure at the valve outlet will affect the ability of the mixing valve to properly control the temperature and may cause premature diaphragm wear.

Fact: An unacceptable (high) pressure loss ratio (PLR) is the primary cause of poor mixing valve/hose station performance.

Symptoms of a high PLR may include

1. Inability to obtain hot water
2. Inability to accurately adjust outlet temperature
3. Inability to stabilize outlet temperature
4. Noisy operation or "chattering"

Results of a high PLR may include

1. Premature component failure
2. Unsafe outlet water temperatures
3. Poor overall product performance

To diagnose a high PLR

1. Identify static inlet steam and water pressures at point of installation.
Note any inlet pressure differentials greater than 2:1 ratio.
2. Remove primary outlet restriction (remove spray nozzle for example)
3. Uncoil hose completely and ensure that there are no kinks or blockages.
4. Operate Hose Station and record performance.

Correcting high PLR

1. Install Pressure regulator(s) and reduce inlet pressure differential*
2. Permanently reduce back pressure/restriction by a) using shorter or less restrictive hose; b) using a less restrictive nozzle (consult Armstrong Hot Water Group for details on our 16 and 22 gpm spray nozzles)
3. Ensure that outlet components such as extension wands and hose reels are not significantly impeding flow.

**Consult flow charts on page 7 to ensure that you maintain adequate supply pressures for the application.*

Mixing Valve Disassembly

Tools required, all available from Armstrong

1. Socket 1-1/2"
2. Allen key 5/32"
3. Allen key 3/16"
4. Allen key 1/4"
5. Open end wrench 1"
6. Assorted flat head screwdrivers

Disassemble the mixing valve in a front to back sequence. Start at the temperature control lever and work towards the base.

1. Shut off the steam and water supplies.
2. Open the outlet shut-off valve and hose nozzle (if equipped) to relieve pressure.
3. Remove the temperature regulating lever by unscrewing the retaining screw and washer (these items may have been previously removed if temperature setting is locked).
4. Remove the gland plate screws and gland plate.
5. Sequentially remove the six retaining screws from the spring loaded bonnet. Maintain pressure against the bonnet while disassembling.
6. Remove the bonnet and spindle assembly.
7. Unscrew the spindle in a clockwise direction and remove from the bonnet.

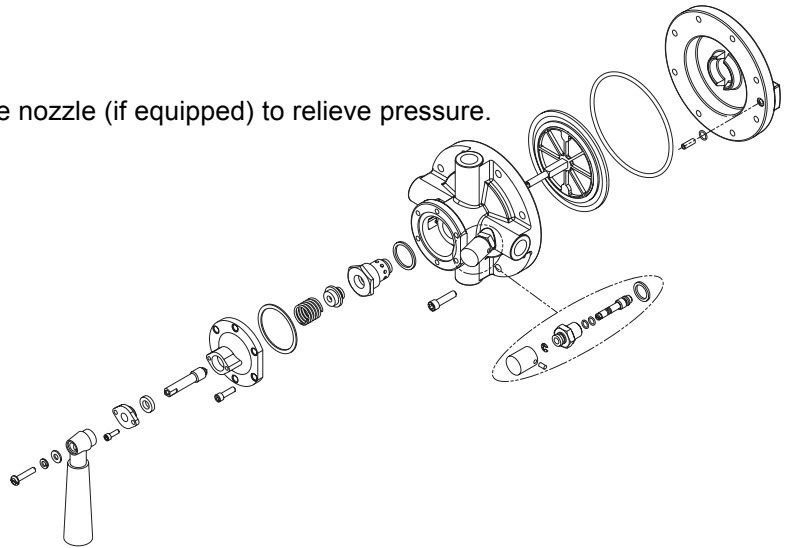

Caution: Do Not twist the poppet when removing or damage to the diaphragm may occur.

Note: Replace the poppet valve and spring as a single unit when damaged.

8. Carefully push out the gland seal packing.
9. Carefully remove the spring and poppet valve from body.
10. Using a 1-1/2" socket remove the diffuser and gasket.
11. Inspect the condition of the diffuser seat and replace if damaged. The diffuser may be de-scaled using a commercial inhibited descaler.

This completes the disassembly of the upper section of the Mixing Valve. To clean or inspect the lower section of the Mixing Valve or if the Diaphragm requires replacement continue with the disassembly procedure in the next section (Diaphragm Replacement). Replace worn or damaged parts as required. Always replace O-rings and gaskets with new ones after disassembly. (Use Service Pack #036-203-520.)

Locking the Unit

Installation Instructions for Tamper Resistant Locking Device

- Figure 1. Tools required: Flat blade screwdriver, Part #042 Locking Device (includes required 3/16" hex key), 3/32" Hex key (supplied with Steamix Valve/Hose Station).
- Figure 2. The cold water regulator is supplied as standard with a locking cap, which can be removed for "fine tune" mode. Locking cap is secured with a set screw and requires a 3/32" hex key for removal.
- Figure 3. Adjust the Mixing Valve on site to the desired outlet temperature set point (refer to pages 9-10 "Start Up Procedure"). Once adjusted and operating satisfactorily, remove and store the temperature control lever.
- Figure 4. Install the locking device and secure the 1/4-20 Hex Socket Head Bolt with the 3/16" Hex Key provided.

Once the Steamix has been set on site and the locking device has been installed the user will only be able to operate the on/off flow control lever.

The installation is now complete and the Steamix 203 must be tested for acceptable temperature and flow prior to being placed into service.

The hex keys provided are not commonly available to plant cleanup personnel. Any subsequent tampering might be regarded by management as premeditated vandalism.

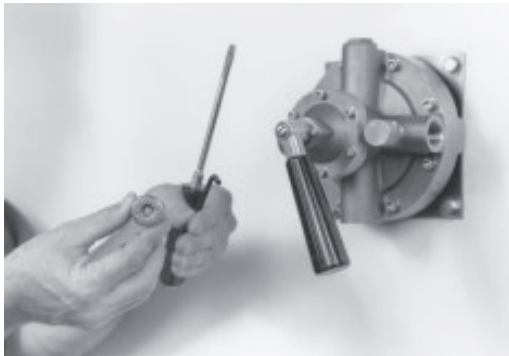

Figure 1.

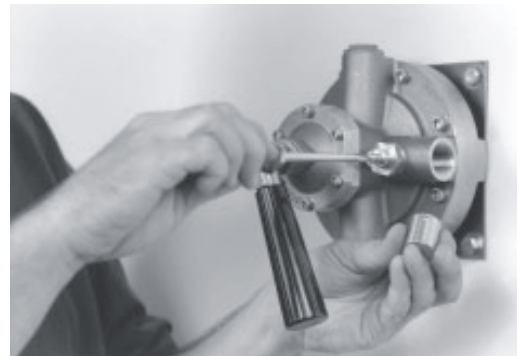

Figure 2.



Figure 3.

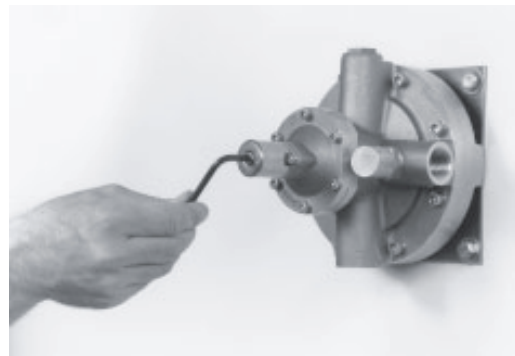

Figure 4.

Millennium/Infinity Edition

When ordering spare parts, please include the valve serial number (located on assembly label), part number and part name.

STEAMIX 203 Mixing Valve Millennium/Infinity Edition Spare Parts

Component ID Code	Description	Component Part Number / Suggested Kit #	Alternate Kits
1	Temperature Control Lever Retaining Screw, Lock Washer and Flat Washer	M2	M1
2	Temperature Control Lever	M1	M3
3	Gland Plate Retaining Screw (2)	M2	
4	Gland Plate	036-203-535	M3
5	Gland Packing	M5	M3
6	Temperature Control Spindle	036-203-590	M3
7	Bonnet Retaining Screw (6)	M2	
8	Bonnet	036-203-630	M3
9	Upper Gasket	M5	M3, M4, M7, M8
10	Return Spring	M4	
11	Poppet Valve	M4	
12	Steam Diffuser	M4	
13	Diffuser Copper Gasket	M4	M5, M7, M8
14	Cover Screw (8)	036-203-570	
15	Body	Consult Factory	
16	Water Flow Regulator Assembly	M6	
17	Diaphragm Assembly	M7	
18	Diaphragm Only	M8	
19	Cover O-Seal	M5	M7, M8
20	Connecting Tube	M5	M7, M8
21	Connecting Tube O-Seal	M5	M7, M8
22	Base	Consult Factory	
23	Water Flow Regulator Spindle O-Seals	M5	
24	Water Flow Regulator Copper Gasket	M5	

Kits for Millennium/Infinity Edition

M1 - Part # 036-203-525

Lever Handle Assembly 203

- 1- Temperature Control Retaining Screw, Lock Washer, Flat Washer
- 2- Temperature Control Lever

M2 - Part # 036-203-560

Upper Screw Pack

- 1- Temperature Control Retaining Screw, Lock Washer, Flat Washer
- 3- Gland Plate Retaining Screw (2)
- 7- Bonnet Retaining Screw (6)

M3 - Part # 203-937-85

Bonnet Assembly Retrofit

- 1- Temperature Control Retaining Screw, Lock Washer, Flat Washer
- 2- Temperature Control Lever
- 3- Gland Plate Retaining Screw (2)
- 4- Gland Plate
- 5- Gland Packing
- 6- Temperature Control Spindle
- 7- Bonnet Retaining Screw (6)
- 8- Bonnet
- 9- Upper Gasket

M4 - Part # 036-203-540

Diffuser/Poppet Valve Pack

- 9- Upper Gasket
- 10- Return Spring
- 11- Poppet Valve
- 12- Steam Diffuser
- 13- Steam Diffuser Copper Gasket

M5 - Part # 036-203-520

Service Kit 203

- 5- Gland Packing
- 9- Upper Gasket
- 13- Steam Diffuser Copper Gasket
- 23- Water Flow Regulator Seal (2)
- 19- Cover O-Seal
- 20- Connecting Tube
- 21- Connecting Tube O-Seal
- 24- Water Flow Regulator Gasket (1)

M6 - Part # 036-203-580

Water Flow Regulator Assembly

- 16- Water Flow Regulator Assembly
- 23- Water Flow Regulator Spindle O-Seals (2)
- 24- Water Flow Regulator Copper Gasket

M7 - Part # 036-203-510

Diaphragm Assembly & Service Pack

Kit includes fully assembled diaphragm, piston, and upper and lower diaphragm retaining plates (item 17 on drawing). Includes Kit M5, Service Kit 203 listed above.

M8 - Part # 036-203-515

Diaphragm & Service Pack

Kit includes diaphragm (item 18 on drawing) **only** and M5 Service Kit 203. Installer must clean and reuse piston and upper and lower diaphragm retaining plates.

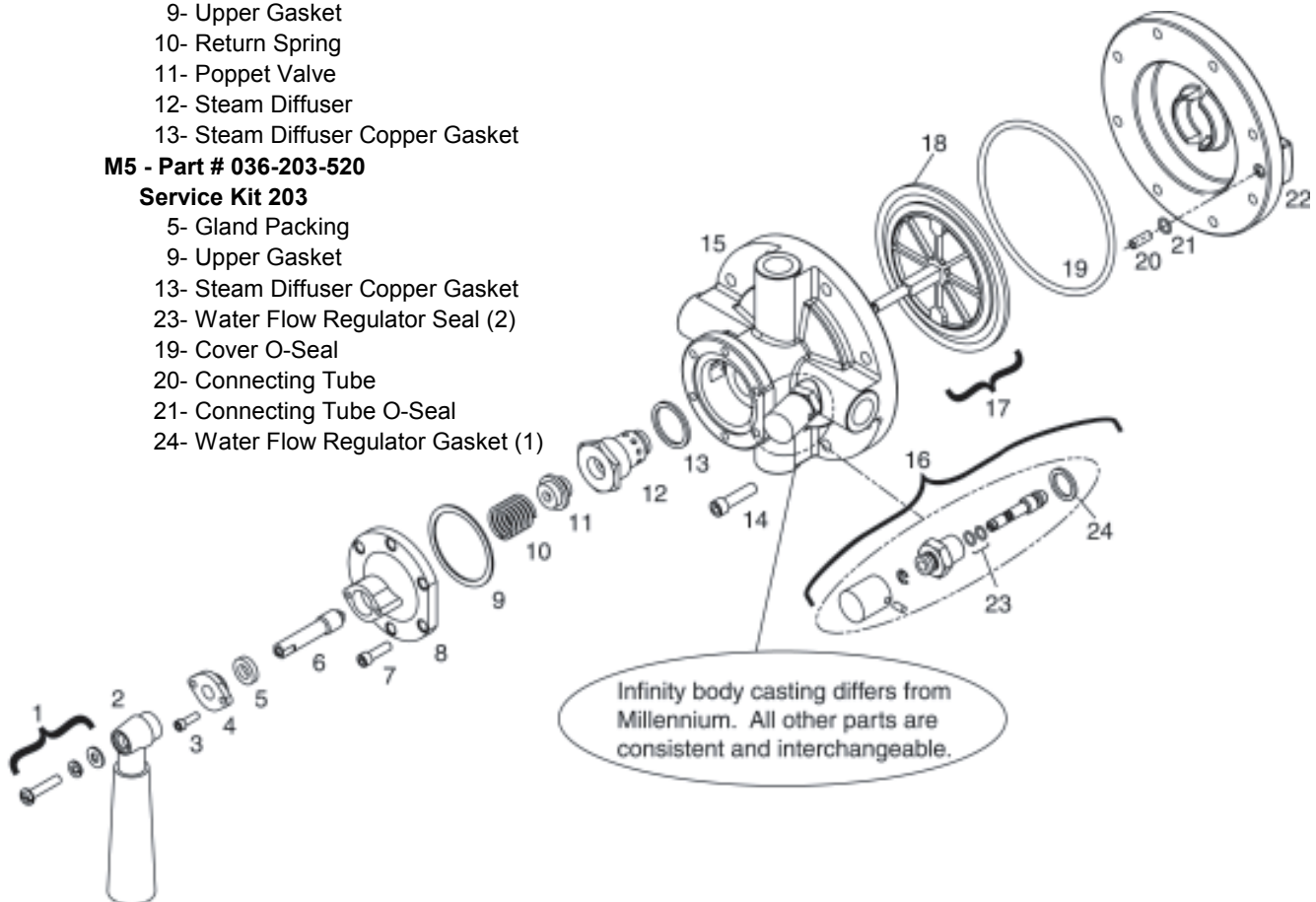

Classic Edition

Important Note:

Steamix 203 has been in production since 1990 and there are three production editions. The "Classic" edition was manufactured from 1990 until 1999. The "Millennium" edition was manufactured from 1999 until 2003. The "Infinity" edition commenced manufacturing in January 2004 and is the current production model. Please review the Millennium/Infinity Edition (page 14) or Classic Edition (below) to identify the unit you own.

Classic Identification

1. Locate the serial number on the valve. Classic valves have the serial number located on the bonnet assembly and begin with the letter A. The serial numbers will range from A1000 to A9000 and will have the identifier Rada 203 in between a red and blue arrow directly after the serial number.
2. The Classic edition has the number 8.065.38.1A cast in raised digits on the underside of the steam inlet (left).
3. The Classic edition has the letters TS cast in raised letters on the underside of the cold water inlet (right).

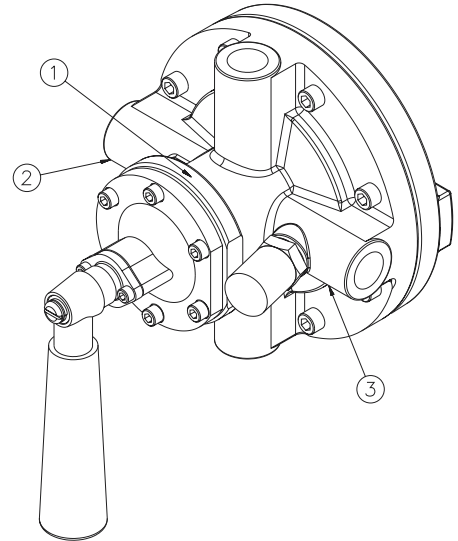

Note: To ensure proper identification accuracy, please confirm at least two of the three valve identifiers before ordering spares.

The Steamix 203's Classic design incorporated simple and rugged construction so that with minimal routine care and operation within the specified limits it should operate trouble free for long periods of time.

All the mixing valve parts are field replaceable using standard tools. However, some internal components have been superseded by parts kits common to the Millennium valve. Refer to substitution detail on pages 21.

Periodic Inspection and Servicing

1. The following should be performed at intervals of one to six months depending on usage and condition of water (hard, soft, acidic or alkaline).
 - a. Evenly tighten the two gland plate set screws to prevent leakage through the gland seal.
 - b. Disassemble the mixing valve and clean internal parts with a good quality commercial inhibited de-scaler.
 - c. Inspect all valve seats for wear, seals and gaskets for nicks or tears and check the condition of the diaphragm.
 - d. Lubricate all moving parts with a high quality silicone based lubricant only.

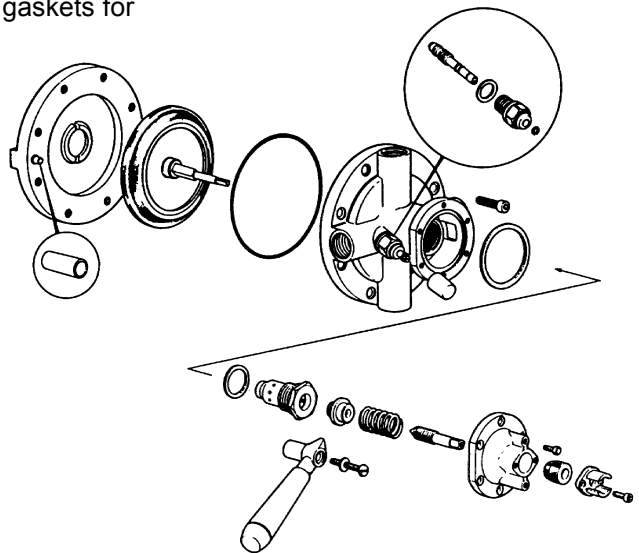

Mixing Valve Disassembly

Tools required, all available from Armstrong Hot Water Group:

- | | |
|------------------------------------|------|
| 1. Socket | 36mm |
| 2. Allen key | 4mm |
| 3. Allen key | 5mm |
| 4. Allen key | 6mm |
| 5. Open end wrench | 24mm |
| 6. Assorted flat head screwdrivers | |

Disassemble the mixing valve in a front to back sequence. Start at the temperature control lever and work towards the base.

1. Shut off the steam and water supplies.
2. Open the outlet shut-off valve and hose nozzle (if equipped) to relieve pressure.
3. Remove the temperature regulating lever by unscrewing the retaining screw and washer (these items may have been previously removed if temperature setting is locked).
4. Remove the gland plate screws and gland plate.
5. Sequentially remove the six retaining screws from the spring loaded bonnet. Maintain pressure against the bonnet while disassembling.
6. Remove the bonnet and spindle assembly.
7. Unscrew the spindle in a clockwise direction and remove from the bonnet.
8. Carefully push out the gland seal packing.
9. Carefully remove the spring and poppet valve from body.
10. Using a 36mm socket remove the diffuser and gasket.
11. Inspect the condition of the diffuser seat and replace if damaged. The diffuser may be de-scaled using a commercial inhibited descaler.

Caution: Do Not twist the poppet when removing or damage to the diaphragm may occur.

Note: Replace the poppet valve and spring as a single unit when damaged.

This completes the disassembly of the upper section of the Mixing Valve. To clean or inspect the lower section of the Mixing Valve or if the Diaphragm requires replacement continue with the disassembly procedure in the next section (Diaphragm Replacement). Replace worn or damaged parts as required. Always replace "O" rings and gaskets with new ones after disassembly. (Use Service Pack #203-937-52.)

Diaphragm Replacement

1. When replacing the diaphragm it is considered good maintenance practice to check over/audit the complete Mixing Valve.
2. To replace the diaphragm disconnect the Mixing Valve from the pipework.
3. Using a diagonal sequence remove the eight valve body retaining screws.
4. Carefully separate the base from the body. Be careful not to lose the connecting tube and "O" ring.
5. Withdraw the diaphragm assembly and inspect for damage. Replace if necessary.
6. If desired, the base, valve body and diaphragm piston may be descaled. **Do not** allow descaler to come in contact with the diaphragm.

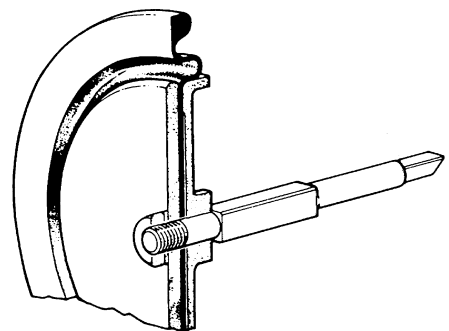

Caution: Use **only** silicone based lubricants when assembling the mixing valve.

7. Re-assemble in the reverse order. Ensure that both the base "O" ring and the connecting tube and the connecting tube "O" ring seat properly. Tighten screws diagonally opposite. Press the triangular spindle that is visible in the top of the valve body to check for free and even movement of the diaphragm assembly.

Complete the locking procedure as follows:

- Fig. 1. Tools required: Flat blade screwdriver, Part #042 Locking Device (includes required 3/16" hex key), 3/32" Hex key (supplied with Steamix Valve/Hose Station).
- Fig. 2. The Cold Water Regulator is supplied as standard with a locking cap, which can be removed for "fine tune" mode. Locking Cap is secured with a set screw and requires a 3/32" hex key for removal.
- Fig. 3. Adjust the Mixing Valve on site to the desired outlet temperature set point. Once adjusted and operating satisfactorily, remove and store the Temperature Control Lever.
- Fig. 4. Install the Locking Device and secure the 1/4-20 Hex Socket Head Bolt with the 3/16 Hex Key provided.

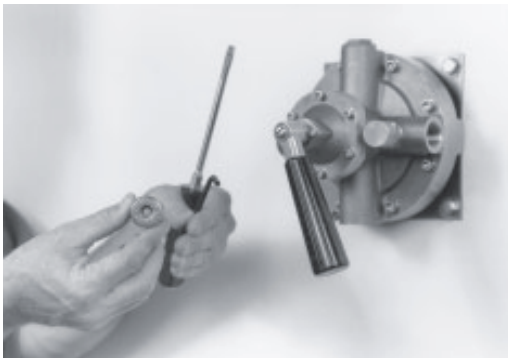

Figure 1.

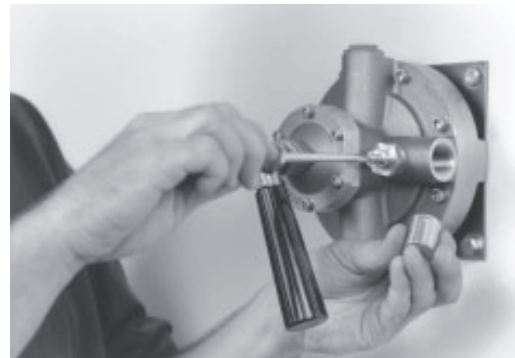

Figure 2.



Figure 3.

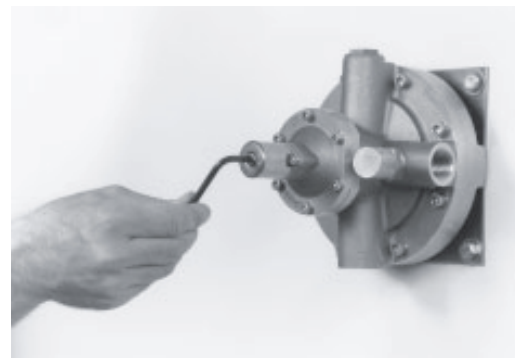

Figure 4.

Once the Steamix has been set on site and the locking device has been installed the user will only be able to operate the on/off flow control lever.

The installation is now complete and the steamix 203 must be tested for acceptable temperature and flow prior to being placed into service.

The Hex Keys provided are not commonly available to plant cleanup personnel. Any subsequent tampering might be regarded by management as premeditated vandalism.

Warning: This product is designed to heat water for industrial washdown, vessel filling and process applications only. Access to extreme water temperatures and flash steam is a possibility. To avoid serious injury use extreme care and wear protective gloves, garments and safety glasses at all times.

Classic Edition

Warning: Highlighted components are no longer available due to a design upgrade.

Replacement Kits which feature new parts have been assembled and include all the components required to correctly replace the original part on your Classic edition Steamix.

Please include the valve serial number, part number and part name.

Component ID Code	Description	Component Part Number / Suggested Kit #
003-21	Base	Consult Factory
012-03	Bonnet Assembly	M3
236-10	Gland Plate	M3
801-31	Body	Consult Factory
856-26	Handle (temperature control lever)	M3
196-07	Flow Regulator Cap	M6
937-50	Diffuser Pack	M4
937-51	Poppet Valve Pack A	M4
937-52	Service Pack B	203-937-52
937-53	Upper Screw Pack C	203-937-53
937-54	Lower Screw Pack D	203-937-54
937-55	Diaphragm Assembly and Service Kit	203-937-55
937-56	Water Flow Regulator Assembly	M6
937-57	Connecting Tube	203-937-57
937-58	Spindle	M3
937-82	Diaphragm Only	203-937-82

Kits for Classic Edition

Part # 203-937-57

Connecting Tube Kit

Connecting Tube

Part # 203-937-82

Diaphragm

Kit includes diaphragm only and Part 203-937-52 Service Kit. Installer must clean and reuse existing piston and upper and lower diaphragm retaining plates.

Part # 203-937-55

Diaphragm Assembly

Kit includes fully assembled diaphragm, piston, and upper and lower diaphragm retaining plates as shown below (part# 937-55). Kit includes Part 203-937-52 Service Kit.

Part # 203-937-52

Service Kit 203

Gland Packing
Diffuser Copper Gasket
Upper Gasket
Water Flow Regulator Copper Gasket
Water Flow Regulator Spindle
O-Seals(2)
Cover O-Seal
Connecting Tube O-Seal

Part # 203-937-85

Bonnet Assembly Retrofit M3*

Temperature Control Retaining Screw, Lock Washer, Flat Washer
Temperature Control Lever
Gland Plate Retaining Screw (2)
Upper Gasket
Gland Plate
Gland Packing
Temperature Control Spindle
Bonnet Retaining Screw (6)
Bonnet

M4* - Part # 036-203-540

Diffuser/Poppet Valve Pack

Upper Gasket
Return Spring
Poppet Valve
Steam Diffuser
Steam Diffuser Copper Gasket

M6* - Part # 036-203-580

Water Flow Regulator Assembly

Water Flow Regulator Assembly
Water Flow Regulator Spindle
O-Seals (2)
Water Flow Regulator Copper Gasket

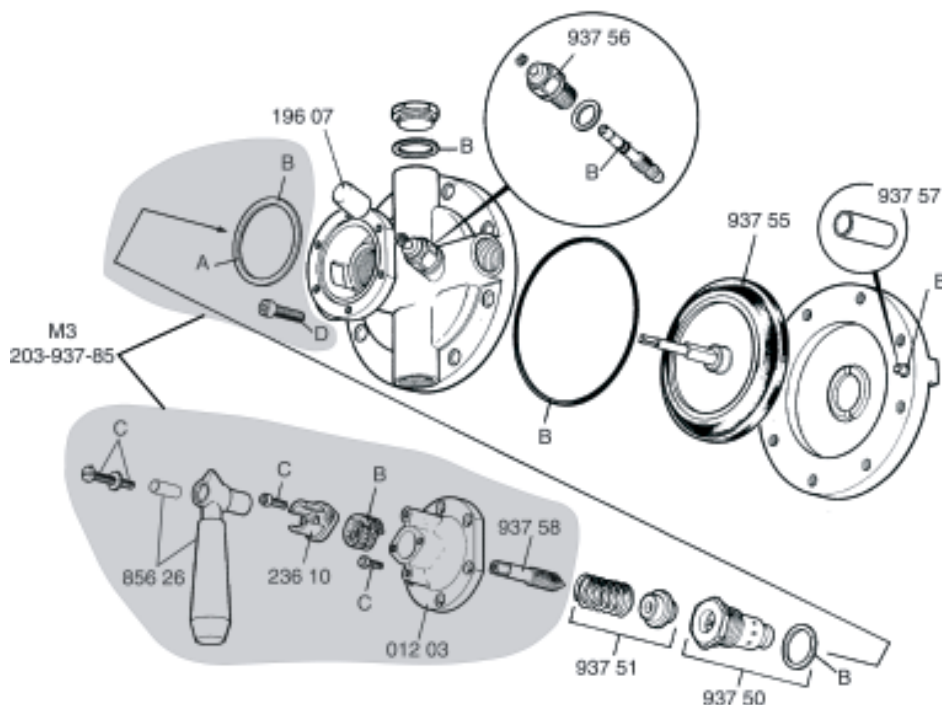

*For further detail and parts identification on Millennium Valve retrofit kits M3, M4 and M6 refer to page 19 of this manual.

Standards and Approvals

Armstrong International, Inc. is an ISO 9001 certified manufacturer.

Armstrong International, Inc. maintains Canadian Registration Numbers specific to Steamix 203 on file.

Warning

Steamix Hose Stations and Mixing Units are specifically designed to heat water to extremely hot temperatures. Failure to observe these warnings could result in serious injury, including severe burns from scalding water and flash steam.

1. **Read and understand all instructions before operating this equipment.**
2. Always check the flow direction of the valve and nozzle before each use.
3. Always point the nozzle in the direction of the arrow.
4. Never point the nozzle or valve at yourself or another person.
5. Always keep hands and fingers clear of the nozzle outlet, mixing valve body and steam inlet.
6. Always check and be aware of the last set position of the temperature control handle before use. The Mixing Valve will automatically rise to the previous temperature setting unless the temperature control handle is returned to its seating position by rotating iclockwiseî to stop.
7. Always check that the Maximum Temperature Lockout feature has not been tampered with or mis-adjusted before use.
8. Always wear water and heat protective gloves, garments, face protection, and safety glasses.
9. Only to be operated by persons trained in this equipment's use and safety.
10. Always return the hose to its holder after use.
11. Always release the water pressure in the hose after use.
12. Always close (shut off) the inlet supply controls after use.
13. Only use this equipment for its intended industrial purpose: washdowns, vessel filling, and process applications.
14. **Do not** substitute any component part on this assembly.
15. Use only performance matched parts for replacement from the Armstrong Hot Water Group.
16. Use of incorrect parts could cause serious personal injury.
17. **Do not** use attachments not authorized by the manufacturer. They may cause fire, electrical shock, or injury.
18. **Do not** operate the equipment if it malfunctions, is dropped, or has been damaged in any manner.
19. **Do not** operate this equipment if its hose is ripped or damaged in any manner.
20. Make **certain** that this equipment is properly installed before use.
21. **Do not** under any circumstances use this product to supply hot water for human showering, bathing, or hand washing applications.
22. This product is unsuitable for use to supply water at any temperature for drench showers, eye wash stations or other emergency equipment.
23. If you have questions, consult this manual or call our Customer Hotline at 1-(888)-HOT-HOSE.

Steamix is a registered trademark of Armstrong Hot Water, a division of Armstrong International, Inc. Steamix is a brand of patented steam/water mixing valves and hose stations. For the purposes of this product manual, the model number Steamix 203 refers to both the Mixing Valve and Mixing Unit as individual products and the Mixing Unit featured on the Steamix Hose Station.

