

Turbine flowmeter

Klinger LWGY Operation manual

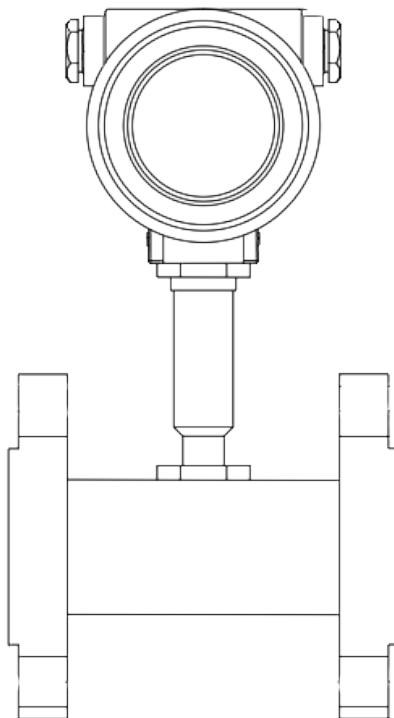

PREFACE

Thank you for purchasing Turbidity/TSS/MLSS controller. Please read this manual carefully before operating and using it correctly to avoid unnecessary losses caused by false operation.

NOTE

- Modification of this manual's contents will not be notified as a result of some factors, such as function upgrading.
- We try our best to guarantee that the manual content is accurate, if you find something wrong or incorrect, please contact us.
- This product is forbidden to use in explosion-proof occasions.

SAFETY PRECAUTIONS

In order to use this product safely, be sure to follow the safety precautions described.

ABOUT THIS MANUAL

- Please submit this manual to the operator for reading.
- Please read the operation manual carefully before applying the instrument. On the precondition of full understanding.
- This manual only describes the functions of the product. The company does not guarantee that the product will be suitable for a particular use by the user.

Precautions for protection, safety and modification of this product

- To ensure safe use of this product and the systems it controls, Please read carefully the operation manual and understand the correct application methods before putting into operation, to avoid unnecessary losses due to operation mistakes. If the instrument is operated in other ways not described in the manual, the protections that the instrument give may be destroyed, and the failures and accidents incurred due to violation of precautions shall not be borne by our company.
- When installing lightning protection devices for this product and its control system, or designing and installing separate safety protection circuits for this product and its control system, it needs to be implemented by other devices.
- If you need to replace parts of the product, please use the model specifications specified by the company.
- This product is not intended for use in systems that are directly related to personal safety. Such as nuclear power equipment, equipment using radioactivity, railway systems, aviation equipment, marine equipment, aviation equipment and medical equipment. If applied, it is the responsibility of the user to use additional equipment or systems to ensure personal safety.

Do not modify this product.

The following safety signs are used in this manual:



Hazard, if not taken with appropriate precautions, will result in serious personal injury, product damage or major property damage.



Warning: Pay special attention to the important information linked to product or particular part in the operation manual.

- Confirm if the supply voltage is in consistent with the rated voltage before operation.
- Don't use the instrument in a flammable and combustible or steam area.
- To prevent from electric shock, operation mistake, a good grounding protection must be made.
- Thunder prevention engineering facilities must be well managed: the shared grounding network shall be grounded at is-electric level, shielded, wires shall be located rationally, SPD surge protector shall be applied properly.
- Some inner parts may carry high voltage. Do not open the square panel in the front except our company personnel or maintenance personnel acknowledged by our company, to avoid electric shock.
- Cut off electric powers before making any checks, to avoid electric shock.
Check the condition of the terminal screws regularly. If it is loose, please tighten it before use.
- It is not allowed to disassemble, process, modify or repair the product without authorization, otherwise it may cause abnormal operation, electric shock or fire accident.
- Wipe the product with a dry cotton cloth. Do not use alcohol, benzine or other organic solvents.
- Prevent all kinds of liquid from splashing on the product. If the product falls into the water, please cut off the power immediately, otherwise there will be leakage, electric shock or even a fire accident.
- Please check the grounding protection status regularly. Do not operate if you think that the protection measures such as grounding protection and fuses are not perfect.

- Don't use the instrument if it is found damaged or deformed at opening of package.
- Prevent dust, wire end, iron fines or other objects from entering the instrument during installation, otherwise, it will cause abnormal movement or failure.
- During operation, to modify configuration, signal output, startup, stop, operation safety shall be fully considered. Operation mistakes may lead to failure and even destruction of the instrument and controlled equipment.
- Each part of the instrument has a certain lifetime, which must be maintained and repaired on a regular basis for long-time use.
- The product shall be scrapped as industrial wastes, to prevent environment pollution.
- When not using this product, be sure to turn off the power switch.
- If you find smoke from the product, smell odor, abnormal noise, etc., please turn off the power switch immediately and contact the company in time.

CONTENTS

1. Overview	2
2. Measuring Range & Pressure	3
3. Installation wiring-use & adjustment	4
4. Basic Parameters & Key Function	8
5. Repairs & Common Faults	12
6. Transportation & Storage	13
7. Calibration of mlss/tss	15
8. Maintenance	16
9. Troubleshooting	17

1. Overview

CFM-LWGY series turbine flow sensor (hereinafter referred to as sensor) is based on the principle of torque balance and belongs to the velocity type flow meter. The sensor has the characteristics of simple structure, light weight, high precision, good repeatability, sensitive response, convenient installation and maintenance, etc. It is widely used in petroleum, chemical, metallurgy, water supply, papermaking and other industries. It is an ideal instrument for flow measurement and energy saving.

The sensor is used in conjunction with the display instrument, and is suitable for measuring liquids in closed pipelines that do not corrode stainless steel 1Cr18Ni9Ti, 2Cr13, Corundum Al₂O₃, and cemented carbide, and have no impurities such as fibers and particles. If it is matched with a display instrument with special functions, it can also carry out quantitative control, excess alarm, etc. The explosion-proof type (Exd IIC T6 Gb) of this product is selected, which can be used in an environment with explosion hazard.

The sensor is suitable for medium with viscosity less than $5 \times 10^{-6} \text{m}^2/\text{s}$ at working temperature. For liquid with viscosity greater than $5 \times 10^{-6} \text{m}^2/\text{s}$, the sensor should be calibrated in real liquid before use.

If the user needs to use a special form of sensor, the order can be negotiated. When an explosion-proof sensor is required, it should be explained in the order.

2. Measuring Range and Pressure

Nominal diameter (mm)	Flow range (m ³ /h)	Pressure rating (Mpa)
DN4	0.04-0.25	Thread 6.4MPa
DN6	0.1-0.6	Thread 6.4MPa
DN10	0.2-1.2	Thread 6.4MPa
DN15	0.6-6	Thread 6.4MPa
		Flange 2.5MPa
DN20	0.8-8	Thread 6.4MPa
		Flange 2.5MPa
DN25	1-10	Thread 6.4MPa
		Flange 2.5MPa
DN32	1.5-15	Thread 6.4MPa
		Flange 2.5MPa
DN40	2-20	Thread 6.4MPa
		Flange 2.5MPa
DN50	4-40	Flange 2.5MPa
DN65	7-70	Flange 1.6MPa
DN80	10-100	Flange 1.6MPa
DN100	20-200	Flange 1.6MPa
DN125	25-250	Flange 1.6MPa
DN150	30-300	Flange 1.6MPa
DN200	80-800	Flange 1.6MPa

3. Installation, Wiring, Use and Adjustment

3.1. Installation

The installation method of the sensor is different according to the specifications, using thread or flange connection, the installation method is shown in Figure 1, Figure 2, Figure 3.

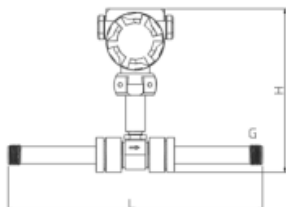

Figure1 DN4-DN10mm
Threaded connection type
(including straight pipe section)

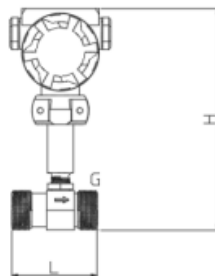

Figure 2 DN15-DN50mm
Threaded connection type

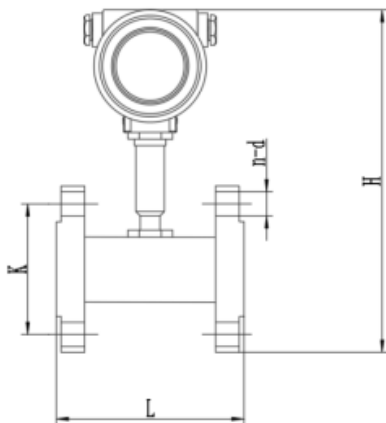
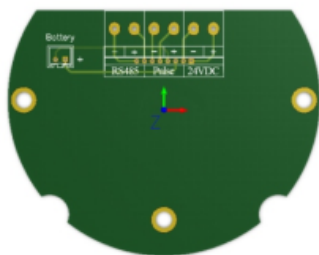

Figure 3 DN15-DN200mm
Flange connection type

Nominal diameter (mm)	Meter length L(mm)	Male thread G	Flange outer diameter D(mm)	Cencer distance K(mm)	Height H(mm)	Bore diameter d(mm)	Bore count (n)
DN4	225	G1/2			200		
DN6	225	G1/2			200		
DN10	345	G1/2	90	60	200	14	4
DN15	75	G1	95	65	260	14	4
DN20	85	G1	105	75	270	14	4
DN25	100	G11/4	115	85	280	14	4
DN32	120	G11/2	140	100	290	18	4
DN40	140	G2	150	110	300	18	4
DN50	150	G21/2	165	125	310	18	4
DN65	175	G3	185	145	330	18	4
DN80	200		200	160	340	18	8
DN100	220		220	180	360	18	8
DN125	250		250	210	390	18	8
DN150	300		285	240	420	22	8
DN200	360		340	295	470	22	12

3.2. Terminal board wiring instructions are as follows



Mark	Function	Notes	
24VDC	+	DC 18-36V	24V+
	-	DC 18-36V	24V-
	Two wire current output		
Pulse	+	Frequency or pulse output +	Frequency or pulse output is passive
	-	Frequency or pulse output -	
Rs485	+	RS485 +	RS485
	-	RS485 -	

The sensor can be installed horizontally and vertically, and the fluid direction must be upwards when installed vertically. The liquid should fill the pipe and there should be no air bubbles. When installing, the direction of liquid flow should be consistent with the direction of the arrow indicating the flow

direction on the sensor housing. The upstream end of the sensor should have at least a straight pipe section with a length of 20 times the nominal diameter, and the downstream end should have a straight pipe section with a length of not less than 5 times the nominal diameter. The axis of the pipeline of the sensor should be aligned with the axis of the adjacent pipeline, and the gasket used for connection and sealing should not penetrate into the inner cavity of the pipeline.

The sensor should be kept away from external electric and magnetic fields, and effective shielding measures should be taken if necessary to avoid external interference.

In order not to affect the normal delivery of the liquid during maintenance, it is recommended to install a bypass pipe at the installation location of the sensor.

When the sensor is installed in the open air, please do waterproof treatment on the amplifier and plug. The wiring between the sensor and the display instrument is shown in Figure 4.

When the fluid contains impurities, a filter should be installed. The mesh of the filter is determined according to the flow rate of impurities, generally 20 to 60 mesh. When the fluid is mixed with free gas, an air eliminator should be installed. The entire piping system should be well sealed.

Users should fully understand the corrosion of the measured medium to prevent the sensor from being corroded.

3.3. Use and adjustment

- When using, the liquid to be tested should be kept clean and free of impurities such as fibers and particles.
- When the sensor starts to use, it should fill the sensor with liquid slowly, and then open the outlet valve. It is strictly forbidden for the sensor to be impacted by high-speed fluid when it is in a liquid-free state.
- The maintenance period of the sensor is generally half a year. When overhauling and cleaning, be careful not to damage the parts in the measuring chamber, especially the impeller. When assembling, please pay attention to the positional relationship between the guide and the impeller.
- When the sensor is not in use, the internal liquid should be cleaned, and protective sleeves should be placed on both ends of the sensor to prevent dust and dirt from entering, and then stored in a dry place.
- The filter should be cleaned regularly when it is used. When not in use, the liquid inside should be cleaned. Like the sensor, add a dust cover and store it in a dry place.
- The transmission cable of the sensor can be laid overhead or buried (iron pipes should be covered

when buried.)

- Before installing the sensor, firstly connect the cable with the display instrument or oscilloscope, turn on the power supply, blow the impeller by mouth or turn the impeller by hand to make it rotate quickly to observe whether there is a display, and then install the sensor when there is a display. If there is no display, check the relevant parts and troubleshoot.

4. Basic Parameters and Key Functions

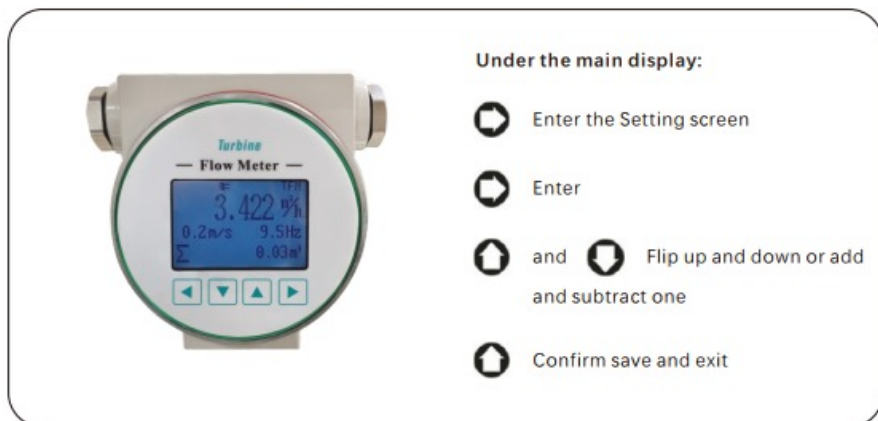

4.1. Instantaneous flow setting

1.1 Flow unit	Options: L/s, L/m, L/h, m ³ /s, m ³ /m, m ³ /h, Nm ³ /s, Nm ³ /m, Nm ³ /h, USG/s, USG/m, USG/h, kg/s, kg/m, kg/h t/s, t/m, t/h Default = m ³ /h Defines the unit of instantaneous flow display
1.2 Flow decimal	Options: 0 1 2 3 defaults = 2 Defines the number of decimal places for the instantaneous flow display
1.3 Flow range	Floating point number: 99999999.00-0.00 m ³ /h default = 100.0 m ³ /h
1.4 Small signal ablation	Floating point number: 9.90 – 0.00 % default = 0.0 %
1.5 High Alarm	Floating point number: 99.00 – 0.00 % default = 100.0 %
1.6 Low Alarm	Floating point number: 99.00 – 1.00 % default = 0.0 %
1.7 Damping time	Floating point number: 90.0 – 0.1 default = 1.0s

4.2. Total flow setting

2.1 Total flow unit	Options: L m ³ Nm ³ USG kg t default=m ³ Defines the units of total display
2.2 Flow decimal	Options:0 1 2 3 default =1 Defines the number of decimal places to display total flow
2.3 Default volume	Floating point number: 99999999-0.00 m ³ default=current total flow After setting this value, the current total amount will be overwritten by this setting value.

Note

If the total shows "Over Flow!", please deal with it in time (clear or preset), so as not to affect the normal measurement.

4.3. Meter calibration

3.1 Zero current calibration	Floating point number: 3.0-5.0 default = 4.000mA
3.2 Current full-scale calibration	Floating point number: 19.0-21.0 default = 20.000mA

Note

When this function is executed, use a precision ammeter to measure the 4-20mA current output, input the reading into the meter, and the meter will automatically complete the calibration operation.

4.4. Output setting

4.1 Signal output	Signal output
4.2 Equivalent output	Options: High-level Low-level default = Low level Define the equivalent output form
4.3 Frequency output	Floating point number: Max:5000-0.00 Hz default=2000Hz

Note

The duty cycle is 50%, the frequency is proportional to the flow rate, the maximum frequency can be set, and the maximum frequency corresponds to the set range flow rate.

The valid high and low levels, the pulse width (ms) of the valid level, and the pulse equivalent (range unit per pulse) can be set.

4.5. Communication setting

5.1 Mode	Options: RTU ASCII default = RTU
5.2 Baud rate	Options: 9600 19200 38400 57600 defaults = 9600
5.3 Calibration mode	Options: NONE ODD EVEN default = 8, NONE
5.4 Device Address	Number: 253 - 1 default = 001

Note

Please refer to the Turbine MODBUS User Manual for the specific operation of communication.

4.6. Factory parameters

Please enter our designated password **100000**

6.1 Sensor diameter	Options: DN 9999-0000 mm default = DN 0050 mm	
6.2 Instrument coefficient /m3	19.0-21.0 mod mode	
6.3 Linear correction	6.3.1 Linear correction 1	Floating point number: 999999.9 – 000000.0Hz default = 0.0Hz Floating point number: 999999.9999 – 000000.0000N/m3 default = 0.0000N/m3
	6.3.2 Linear correction 2	Floating point number: 999999.9 – 000000.0Hz default = 0.0Hz Floating point number: 999999.9999 – 000000.0000N/m3 default = 0.0000N/m3
	6.3.3 Linear correction 3	Floating point number: 999999.9 – 000000.0Hz default = 0.0Hz Floating point number: 999999.9999 – 000000.0000N/m3 default = 0.0000N/m3
	6.3.4 Linear correction 4	Floating point number: 999999.9 – 000000.0Hz default = 0.0Hz Floating point number: 999999.9999 – 000000.0000N/m3 default = 0.0000N/m3
	6.3.5 Linear correction 5	Floating point number: 999999.9 – 000000.0Hz default = 0.0Hz Floating point number: 999999.9999 – 000000.0000N/m3 default = 0.0000N/m3
6.4 Fluid density	Floating point number: 9999.99–0000.00kg/m3 default=1000.00kg/m3 When you want to use mass units, set the exact density!	
6.6.5 Language Setting	Options: Chinese English default = Chinese	

Appendix (I) Menu

Instantaneous flow	Total flow setting	Meter calibration	Output settings	Communication setting	Factory parameters
Flow unit	Total flow unit	Zero current calibration	Signal output	Model	Sensor diameter
Flow decimal	Flow decimal	Current full-scale calibration	Equivalent output	Baud rate	Instrument coefficient
Flow range	Default volume		Frequency output	Calibration mode	Linear correction
Small signal ablation				Device Address	Fluid density
High Alarm					Language Setting
Low Alarm					
Damping time					

Appendix (II) RS485 communication address table

Variable address definition:

Variable name	Register first address	Register length	Instruction code	Data type
Instantaneous flow	0x01	0x02	0x04	Float Floating-point number
Instantaneous flow unit	0x03	0x01	0x04	Int Integer
Total flow	0x04	0x04	0x04	Double precision
Total flow unit	0x08	0x01	0x04	Int Integer
Total flow(m ³)	0x0d	0x02	0x03 0x04	Float Floating-point number
Instantaneous flow	0x14	0x02	0x04	float Floating-point number
Total flow	0x16	0x02	0x04	float Floating-point number
Instantaneous flow	0x1e	0x02	0x04	float inverse
Total flow	0x20	0x02	0x04	float inverse

Unit:

	Unit	Code
Instantaneous flow	m ³ /h	0x03
	m ³ /m	0x04
	m ³ /s	0x05
	L/h	0x06
	L/m	0x07
	L/s	0x08
	usg/h	0x09
	usg/m	0x0a
	usg/s	0x0b
	kg/h	0x0c
	kg/m	0x0d
	kg/s	0x0e
	t/h	0x0f
	t/m	0x10
t/s	0x11	
Total flow	m ³	0x01
	L	0x02
	usg	0x03
	kg	0x04
	t	0x05

5. Repairs and Common Faults

The general faults that may be caused by the sensor and their elimination methods are shown in the following table, and the maintenance period should not exceed half a year.

Item	Fault Phenomenon	Cause	Elimination method
1	The display instrument has no display on the flow signal and the inspection signal.	<ol style="list-style-type: none"> 1. The power supply is not turned on, and the given voltage is incorrect. 2. The display device is faulty. 	<ol style="list-style-type: none"> 1. Turn on the power supply and give the voltage as required. 2. Overhaul the display instrument.
2	The display instrument has a display on the "calibration" signal but no display on the flow signal.	<ol style="list-style-type: none"> 1. The wiring between the sensor and the display is incorrect, or there are open circuit, short circuit, poor contact and other faults 2. The amplifier is faulty or damaged. 3. The converter (coil) is open circuit or short circuit. 4. The impeller is stuck. <p>No fluid flow or blockage in the pipe.</p>	<ol style="list-style-type: none"> 1. Check the correctness and quality of the wiring according to Figure 4. 2. Repair or replace the amplifier. 3. Repair or replace the coil. 4. Clean the sensor and pipes. Open the valve or pump and clean the pipeline.
3	The display instrument is unstable; the measurement is incorrect.	<ol style="list-style-type: none"> 1. The actual flow exceeds the measuring range of the instrument or is unstable. 2. The meter coefficient K is set incorrectly. 3. Impurities such as fibers are hung in the sensor. 4. There are bubbles in the liquid. 5. There is strong electromagnetic field interference next to the sensor. 6. The sensor bearing and shaft are severely worn. 7. The shielding layer of the sensor cable or other grounding wires are disconnected or in poor contact with the line grounding wire. 8. Display instrument failure. 	<ol style="list-style-type: none"> 1. Adapt the measured flow to the measuring range of the sensor, and stabilize the flow. 2. Make the coefficient K set correctly. 3. Clean the sensor. 4. Take measures to eliminate air bubbles. 5. Try to stay away from interference sources or take shielding measures. 6. Replace the "guide" or "impeller shaft". 7. Connect the wires according to Figure 4. Repair display instrument.

The manufacturer can repair the sensor free of charge if the sensor fails to work properly due to poor manufacturing within one year from the date of delivery from the manufacturer if the user follows the instructions in the manual for storage and use.

6. Transportation and Storage

The sensor should be put into a solid wooden box or carton, and it is not allowed to move freely in the box. It should be handled with care when handling, and brutal loading and unloading is not allowed.

The storage location should meet the following conditions:

- Rainproof and moistureproof.
- Not subject to mechanical vibration or shock.
- Temperature range $-20^{\circ}\text{C}\sim+55^{\circ}\text{C}$.
- The relative humidity is not more than 80%.
- The environment does not contain corrosive gases.

6.1 Unpacking Precautions

- After unpacking, check whether the documents and accessories are complete according to the packing list.
- Packing documents include: One instruction manual; One product certificate
- Observe whether the sensor is damaged due to transportation, so as to handle it properly.
- Keep the "Qualification Certificate" properly and do not lose it, otherwise the meter coefficient cannot be set!

6.2 Ordering Instruction

When ordering the turbine flow sensor, users should pay attention to selecting the appropriate specifications according to the nominal diameter of the fluid, working pressure, working temperature, flow range, fluid type and environmental conditions. When there is an explosion-proof requirement, an explosion-proof sensor must be selected, and strict attention should be paid to the explosion-proof level.

When you need our company's display instrument matching, please refer to the corresponding manual, select the appropriate model, or our company's technical staff will design and select the model for you according to the information provided by you. When a cable for signal transmission is required, specify the length of the specification.

Example of turbidity reading:

Sent from computer: 00 03 00 00 00 02 C5 DA

Returned by dissolved oxygen meter: 00 03 04 00 00 00 00 EA F3

Return command annotation:

00 is the slave address, settable in the instrument;

03 is the function code, reading and holding register;

04 is the data length of returned turbidity value, which is 4 bytes;

00 00 00 00 is the returned turbidity value 0.00NTU, and the obtained value

EA F3 is the CRC16 check code, varying with the previous data;

Example of MLSS/TSS reading:

Sent from computer: 00 03 00 02 00 02 64 1A

Returned by dissolved oxygen meter: 00 03 04 00 00 00 00 EA F3

Return command annotation:

00 is the slave address, settable in the instrument;

03 is the function code, reading and holding register;

04 is the data length of returned MLSS/TSS value, which is 4 bytes;

00 00 00 00 is the returned MLSS/TSS value 0.0mg/L, and the obtained value divided by 10 is the current MLSS/TSS value. The range is 0.0-120000mg/L;

EA F3 is the CRC16 check code, varying with the previous data;

7. Calibration of MLSS/TSS

The MLSS/TSS sensor has been factory calibrated before delivered, and the self-calibration can be carried out according to the following steps if required. The use of standard liquid is required for the calibration of the MLSS/TSS, taking two-point calibration as an example:

- Connect the sensor to the transmitter.
- Set up the related parameters (set the MLSS/TSS factor as 1 in the signal setting), enter the MLSS/TSS Calibration actual value measurement interface and clean the sensor.
Put the probe into the first point standard liquid (usually take the pure water as the first point).
- After the data is stable, read the actual value of the measurement and record the data.
- Remove the probe from the first standard liquid, rinse it with clean water, and wipe the sensor.
- Put the probe into the second standard liquid. After the data is stable, read the actual value of the measurement and record the data.
- Click OK after recording the data; enter the standard selection interface and select the two-point calibration; enter the first target value setting interface.
- Enter the target value of the first standard liquid measured at the laboratory and click OK; enter the first point actual value setting interface and then enter the first point actual value recorded in step 3; click OK to enter the second point target value interface.
- Enter the target value of the second standard liquid measured at the laboratory and click OK; enter the second point actual value setting interface and then enter the second point actual value recorded in step 3; click OK to return the main menu.
- The four-point correction step is basically the same as the two-point correction, and the selection of the correction points can be determined according to the actual measurement environment.
- They are usually the zero point, 0.25 times the range point, 0.5 times the range point and the full range point.

8. Maintenance

Cleaning of sensors

Two lenses on the sensor need to be cleaned. Please regularly carry out cleaning and maintenance in accordance with actual use to ensure the accuracy of the measurement. Rinse it with clean water first and then wipe it with cleaners and rag to remove stubborn stains.

Sensor damage inspection

Check the appearance of the sensor for any breakage. If there is any breakage, it is necessary to contact the after-sales service center timely for replacement to prevent water from getting into sensor due to breakage causing failure.

Replacement of sensor scraper

For the sensor with scrapers, it is suggested to replace the rubber scraper every quarter. Scraper position showed as figure 17, specific steps as follow:



The position of the scraper is as shown in the figure above;

- Unscrew the screw next to the scraper with a corresponding screwdriver;
- Remove the scraper, then remove the rubber sheet inside and replace it with a new rubber scraper;
- Finally, put the scraper back, and tighten the screw and the scraper with a screwdriver.

9. Troubleshooting

🔍 No display of the controller?

🔧 A: Check whether the power line is connected correctly and whether the power supply is connected.

🔍 Displaying figures jumping up and down?

🔧 A: Check whether there is any interference equipment such as the frequency converter. Be careful to keep it away from these interference devices or take shielding measures.

🔍 Transmitter displaying horizontal bar?

🔧 A: The sensor is connected abnormally or water gets into the sensor; if water gets into the sensor, please send the probe to the After-sale.

Maintenance Department in time for checking and repair.

KLINGER Danmark A/S
Nyager 12-14
DK-2605 Brøndby
Denmark
Phone +45 4364 6611