

USERS MANUAL

Strainer	zSTRA	Fig. 821, 823	Edition: 01/2020 Date: 07.05.2020
-----------------	--------------	----------------------	--

CONTENTS

1. Product description
2. Requirement for maintenance staff
3. Transport and storage
4. Function
5. Application
6. Assembly
7. Maintenance
8. Service and repair
9. Reasons of operating disturbances and remedy
10. Valve service discontinuity
11. WZF 100 filter pollution indicator
12. Warranty terms

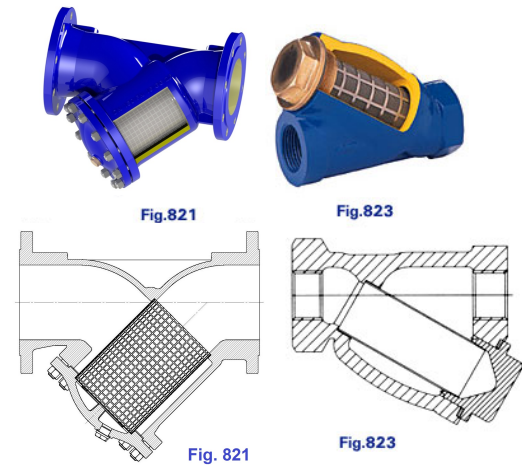

1. PRODUCT DESCRIPTION

	figure 821		figure 823
	ends flange form Y-type		ends threaded form Y-type

Y strainers - filters are provided with casted marking according to requirements of PN-EN19 standard. The marking facilitates technical identification and contains:

- diameter nominal DN (mm),
- pressure nominal PN (bar),
- body and cover material marking,
- arrow indicating medium flow direction,
- manufacturer marking,
- heat number,
- CE marking, for valves subjected 2014/68/UE directive. CE marking starts from DN32

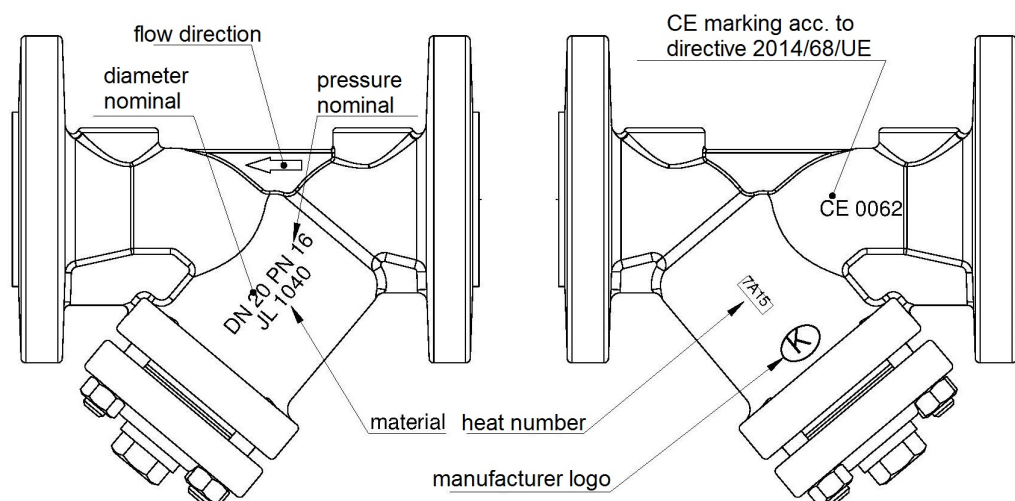

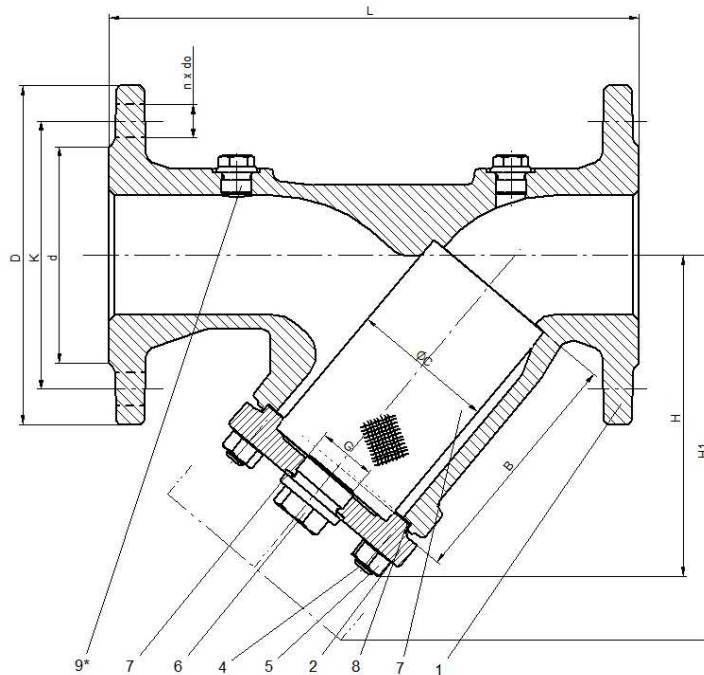

	Body material	A	C	F	I
1	Body	EN- GJL- 250 5.1301 (ex.JL 1040)	EN-GJS-400-18-LT 5.3103 (ex.JS 1025)	GP240GH 1.0619	G-X5CrNiMo19-11-2 1.4408
2	Cover	EN- GJL- 250 5.1301 (ex.JL 1040)	EN-GJS-400-18-LT 5.3103 (ex.JS 1025)	GP240GH 1.0619	G-X5CrNiMo19-11-2 1.4408
3	Screen	X5CrNi 18-10 1.4301			
3.1	Supporting basket	X5CrNi 18-10 for DN ≥ 150 1.4301			
4	Studs	5.6-A3A	A2-70	25CrMo4	A4-70
5	Hexagon nut	5-A3A	A2-70	25CrMo4	A4-70
6	Emptying screw	C35E			A2
7	Plug gasket	A4 1.4571			
8	Cover gasket	CrNiSt – Graphite			
9	Plug *,**	C35E			A2
Max. temperature		300°C	350°C	450°C	400°C

* position of the plug don't refer to PN 6

** plugs on client's request

2. REQUIREMENTS FOR MAINTENANCE STAFF

The staff assigned to assembly, operating and maintenance tasks should be qualified to carry out such jobs. If during strainer operation heat parts of the strainer, for example cover or body could cause burn, user is obliged to protect them against touch.

3. TRANSPORT AND STORAGE

Transport and storage should be carried out at temperature from -20°C to 65°C , and strainers should be protected against external forces influence and destruction of painting layer as well. The aim of painting layer is to protect the strainers against rust during transport and storage. Strainers should be kept at unpolluted rooms and they should be also protected against influence of atmospheric conditions. There should be applied drying agent or heating at damp rooms in order to prevent condensate formation. Strainer weights are given at catalogue card.

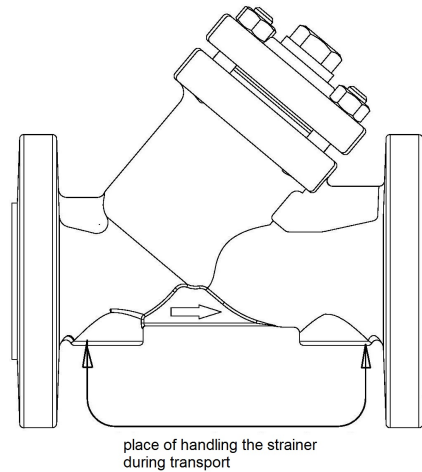
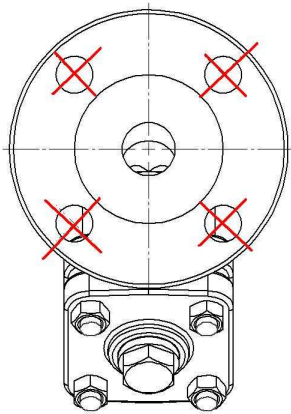

It is not allowed to fit lifting devices to connecting holes.

4. FUNCTION

Strainers – wire mesh filters are designed for cleaning flowing medium. Their task is to protect against pollutions the most sensitive plant components such as pumps, control valves, flow and heat meters. Strainer holds solid particles which dimensions exceeds screen mesh. In order to remove magnetic pollutions from the medium it is recommended to use magnetic cartridge located in the centre of filter screen.

Application range was mentioned at catalogue card. The kind of working medium makes some materials to be use or to be prohibited for use. Strainers were designed for normal working conditions. In the case that working conditions exceed these requirements (for example for aggressive or abrasive medium) user should ask manufacturer before placing an order.

When selecting the strainer for specific medium, "List of Chemical Resistance" can be helpful. It can be found at manufacturer website near catalogue cards.

Working pressure should be adapted to maximum medium temperature according to the table as below :

Acc. to EN 1092-2		Temperature [° C]					
Material	PN	from -10 up to 120	150	200	250	300	350
EN-GJL-250	6	6 bar	5,4 bar	4,8 bar	4,2 bar	3,6 bar	-----
EN-GJL-250	16	16 bar	14,4 bar	12,8 bar	11,2 bar	9,6 bar	-----
EN-GJS-400-18 LT	16	16 bar	15,5 bar	14,7 bar	13,9 bar	12,8 bar	11,2 bar
EN-GJS-400-18 LT	25	25 bar	24,3 bar	23 bar	21,8 bar	20 bar	17,5 bar

Acc EN 1092-1			Temperature [° C]									
Material	PN		From -20 up to -10	From -10 up to 50	100	150	200	250	300	350	400	450
GP240GH	40	bar	30	40	37,1	35,2	33,3	30,4	27,6	25,7	23,8	13,1
Material	PN		From -60 < up to <-10	From -10 < up to <100	150	200	250	300	350	400	450	
G-X5CrNiMo19-11-2	40	bar	40	40	36,3	33,7	31,8	29,7	28,5	27,4	-	



Plant designer is responsible for strainer selection suitable for working conditions.

5. APPLICATION

- hot and cold water plants , steam, air, glycol.
- industrial technologies, power industry, heat industry, HVAC plants

6. ASSEMBLY

During the assembly of strainers following rules should be observed:

- to evaluate before an assembly if the strainers were not damaged during the transport or storage
- to make sure that applied strainers are suitable for working conditions and medium used in the plant
- to take off dust caps if the strainers are provided with them

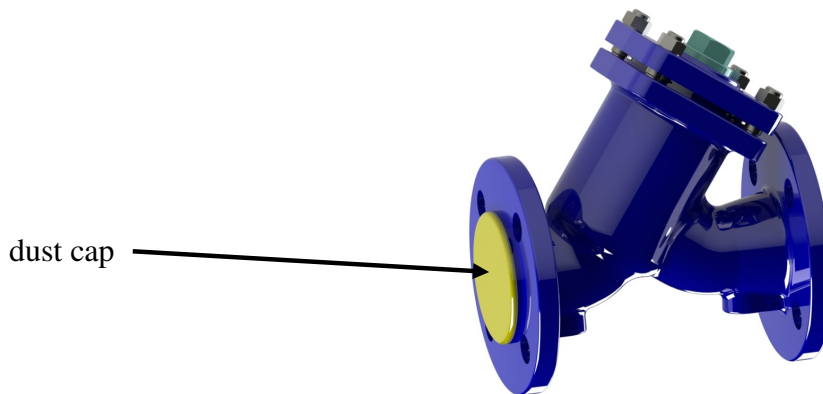

- check if strainer body is free of solid particles
- steam pipelines should be fitted in such a way to avoid condensate collection
- to protect the strainers during welding jobs against splinters and used plastics against excessive temperature



Pipeline where the strainers are fitted should be conducted and assembled in such a way that the strainer body is not subjected to bending moment and stretching forces.

Bolted joints on the pipeline must not cause additional stress resulted from excessive tightening, and fastener materials must comply with working conditions of the plant.



To assembly the strainer in such a way that flow direction comply with an arrow placed on the body.

- strainer body throat with a screen must be put downwards in order to prevent pollution return to the pipeline,

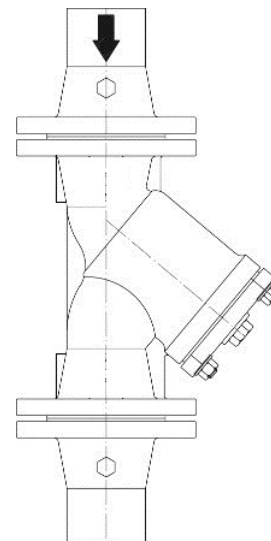
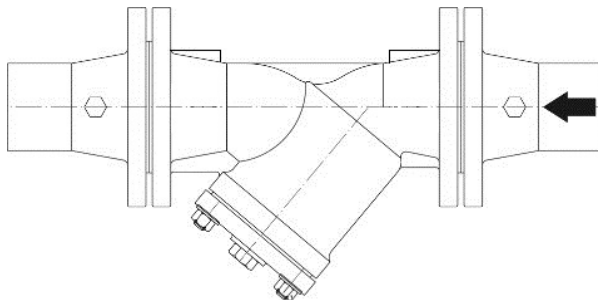

- in the case of water hammer risk caused by condensate formation, strainer body throat should be assembled in horizontal position,

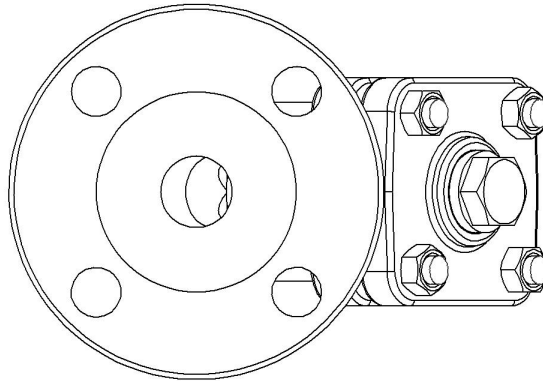

- plant designer should ensure enough space to take screen out of strainer body for cleaning,
- use expansion pipe joints in order to reduce influence of pipeline thermal expansion,
- before plant startup, especially after repairs carried out, flash out the pipeline

7. MAINTENANCE

During maintenance following rules should be observed:

- startup process – sudden changes of pressure and temperature should be avoided when starting the plant,
- strainers – wire mesh filters do not contain moving parts and do not require any maintenance jobs with exception of screen cleaning,
- strainer screens require regular cleaning – screen cleaning intervals should be established by user depending on the pollution grade of the medium,



Before taking up any service jobs make sure that medium supply to the pipeline was cut off, pressure was decreased to ambient pressure, medium was removed from the pipeline and plant was cooled down.

- cleaning or replacement the screen is possible when body – cover bolt nuts are unscrewed and screen is taken out of the strainer – remove screen impurities by strong water stream without using metal tools,
- some part of impurities can be removed by unscrewing the plug from the cover if strainer is provided with plug
- before strainer reassembly remember to replace body – cover gasket.



Precautions should be taken when touching gasket between body and strainer cover. The gasket contains stainless steel stripe that may cause injury,

- tighten hexagon nuts of cover bolts evenly and crosswise by torque wrench

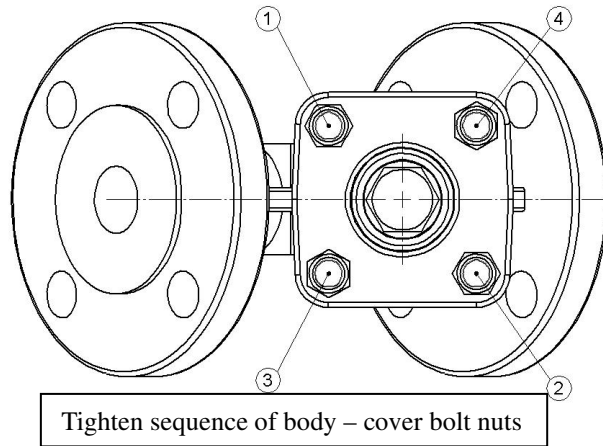

In order to assure safety performance, each strainer (especially rarely used) should be surveyed on regular basis. Inspection frequency should be laid down by user, but not less than one time per month.

8. SERVICE AND REPAIR

All service and repair jobs should be carried out by authorized staff using suitable tools and original spare parts. Before disassembly of complete strainer from the pipeline or before service, the pipeline should be out of operation. During service and repair jobs:

- the pressure should be decreased to zero degrees and valve temperature to ambient temperature,
- personal health protectives in pursuance of existing threat should be used,
- after strainer disassembly it is necessary to replace flange connection gaskets between strainer and pipeline,
- tighten torques for body – cover bolts

Screw	Torque
M8	15-20 Nm
M10	35 -40 Nm
M12	65 – 70 Nm
M16	140 -150 Nm
M24	350-400 Nm

- before strainer re-assembly in the pipeline it is necessary to check strainer operation and tightness of all connections. Tightness test should be carried out with water pressure of 1,5 nominal pressure of the valve.

9. REASONS OF OPERATING DISTURBANCES AND REMEDY



When seeking of strainer malfunction reasons safety rules should be strictly obeyed

Fault	Possible reason	Remedy
No flow	Flange dust caps were not removed	Remove dust caps on the flanges
Poor flow	Dirty screen	Clean or replace the screen
	Clogged pipeline	Check the pipeline
Broken connecting flange	Bolts tighten unevenly	Replace the strainer with new one

10. VALVE SERVICE DISCONTINUITY

All obsolete and dismantled valves must not be disposed with household waste. ZETKAMA valves are made of materials which can be re-used and should be delivered to designated recycling centres.

11. WZF 100 filter pollution indicator

1. Description

WZF 100 - filter pollution indicator, operating on the principle of measuring pressure difference before and after the filter. The measurement is carried out by a magnetic field sensor that measures a displacement of a magnet placed on the sensor's piston.

The indicator is available in version with battery power supply and output and power supply from 4-20 mA current loop,



The indicators are powered by a battery that allows to use the indicator in places without mains power. In the case of a version equipped with a 4-20 mA output, it is possible to permanently supply the sensor from the current loop. Display of the pollution status is carried out for all versions by means of a display made up of LEDs, two green ones, two orange ones and one red one. In addition, a blue LED indicates power on.

Differential pressure:

- 1 green LED - 20% of the measuring range
- 2 green LEDs - 40%
- 1 orange LED - 60%
- 2 orange LEDs - 80%
- 1 red LED - 100%



zasilanie 20 % 40 % 60 % 80 % 100 %

Remote reading is also possible by measuring the current.

Sensor parameters:

Ambient temperature from -20°C to 70°C

Medium temperature 120°C

Medium - cold and hot water, neutral agents

Differential pressure measurement range from 0 bar to 1,2 bar

Maximum static pressure 16 bar

External and current loop power supply 16÷32 V DC

Degree of protection IP 66

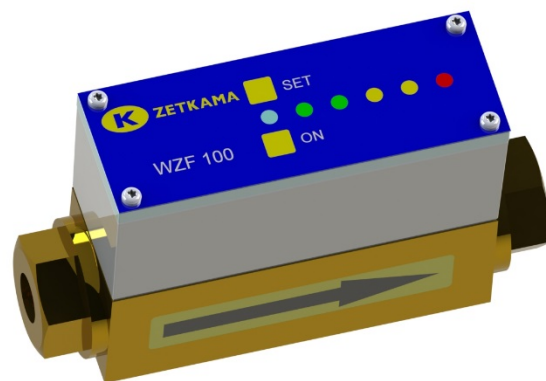

2. Connecting the power supply to the indicator

Each version of the sensor has a built-in CR1216 battery, which is switched on with ON button. Holding down the button allows to start measurement and to read the result on the LED display.

The low voltage status on the battery is indicated by red diode blinking.

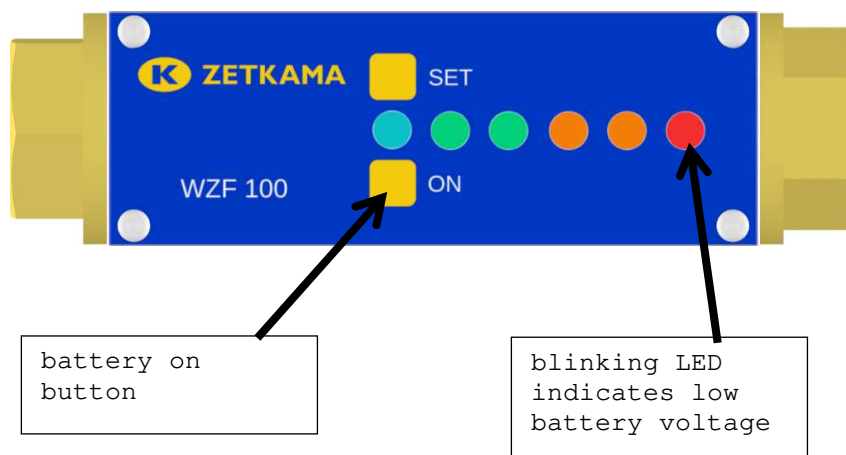

Battery change.

To replace the battery, unscrew the indicator cover under which the socket containing the battery is located.

Use a small screwdriver to pry off the battery from the support plate.

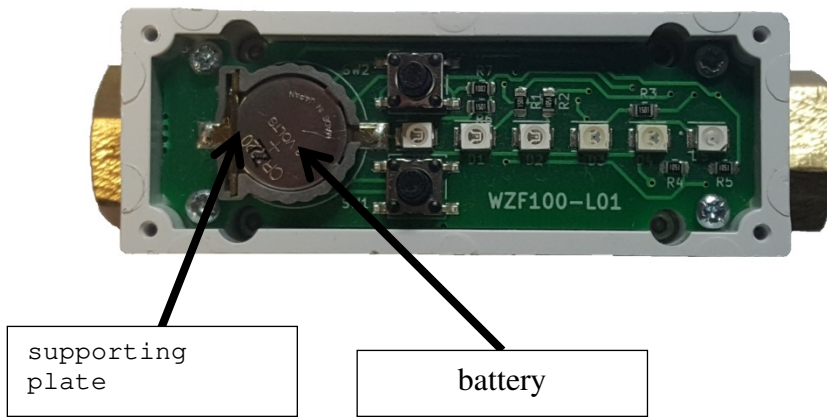

External power supply can be connected in the 4-20 mA or Wi-Fi sensor version. The sensor is equipped with a round M8 standard connector. Plus of voltage should be connected to pin 1 and minus to pin 3.

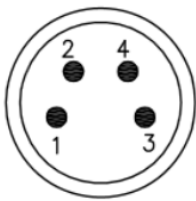

1	power +
2	not connected
3	power -
4	not connected

3. Calibration of the indicator

The indicator is normally calibrated before delivery to a customer. In case of finding that at zero differential pressure one of the diodes is on or that at the maximum pressure does not light up all the LEDs, the indicator can be calibrated again. Calibration can be performed for the first 10 minutes after connecting power supply.

Calibration is performed in two steps:

- Calibration for zero differential pressure.
- Calibration for maximum differential pressure.

To perform the calibration for zero differential pressure, press and hold the SET button. Then, the second green LED should start blinking every 0.5s. Hold the button until the first orange LED blinks simultaneously. To confirm the setting, release the SET button briefly and press again. During recording, the orange LED is permanently on. After the diode goes out, the procedure is finished and you can release the SET button.

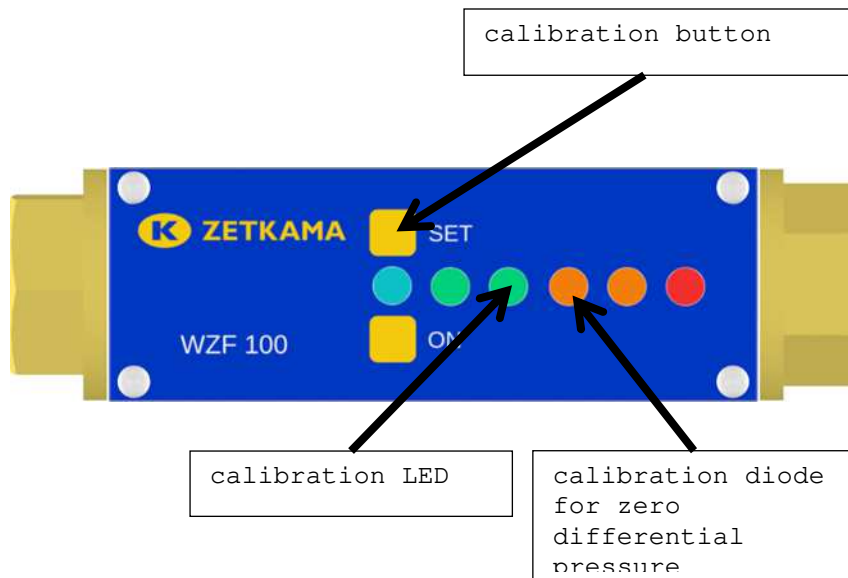

In order to perform the calibration for the maximum differential pressure, the pressure at input must exceed the maximum range. The piston located in the indicator will then move to the maximum position. Then press and hold the SET button. Then, the second green LED should start blinking every 0.5s. Hold the button until the second orange LED blinks simultaneously. To confirm the setting, release the SET button briefly and press again. During recording, the orange LED is permanently on. After the diode goes out, the procedure is finished and you can release the SET button.

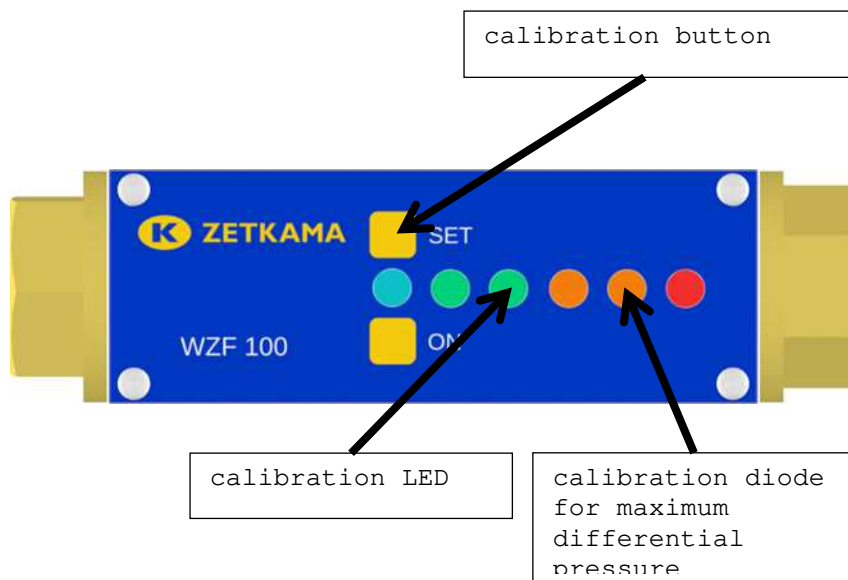

4. Installation of the indicator on the filter

To mount the indicator, order a filter drilled and plugged with G1/4" plugs.

6.1. Remove the two G1/4" plugs from the filter supplied and replace them with zG1/4- w M10x1 reducers using adhesive.

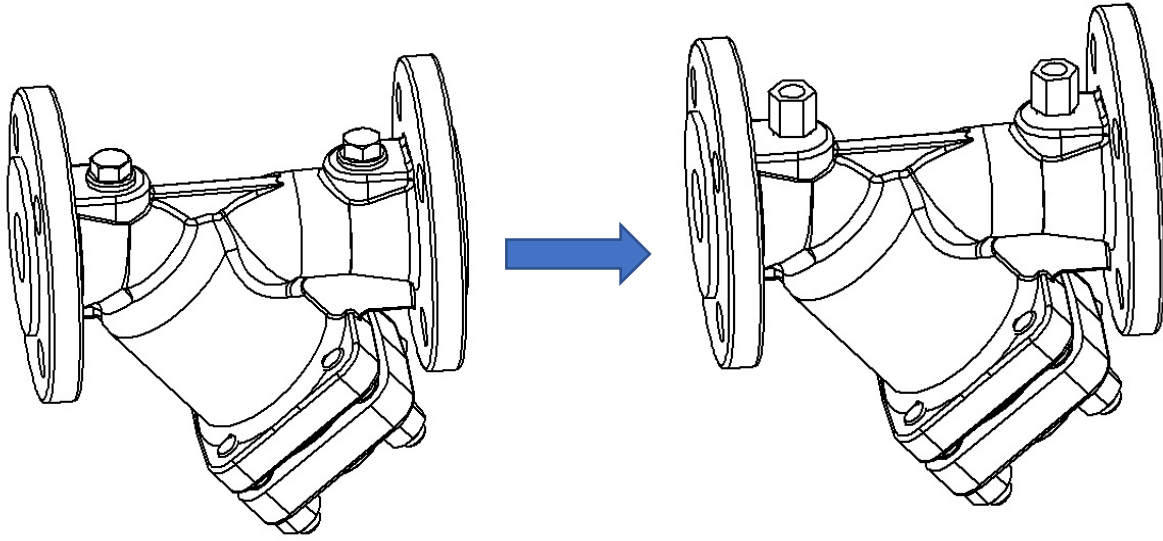

6.2. Add two tubes with M10x1 connectors to the pollution indicator

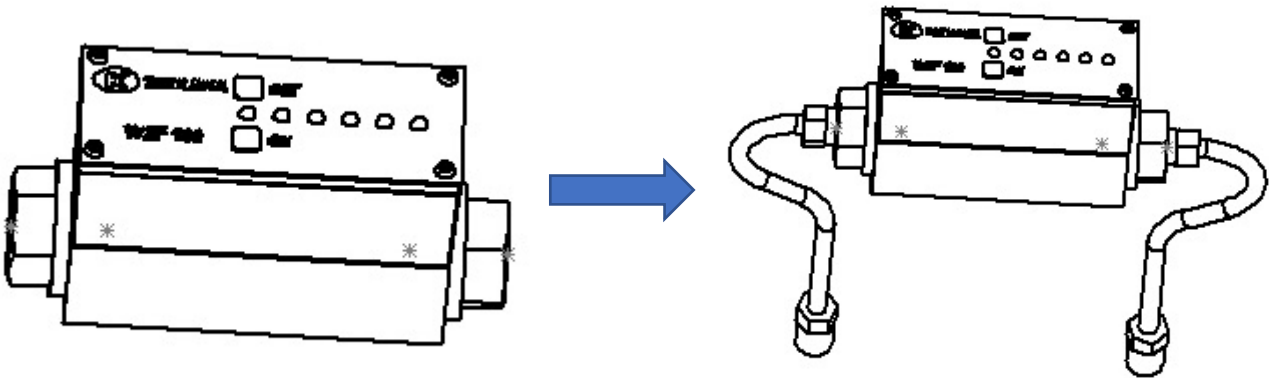

6.3. Attach the indicator with the tubes to the filter with the screwed reducers.
Remember that the direction of flow on the indicator and filter should be the same.

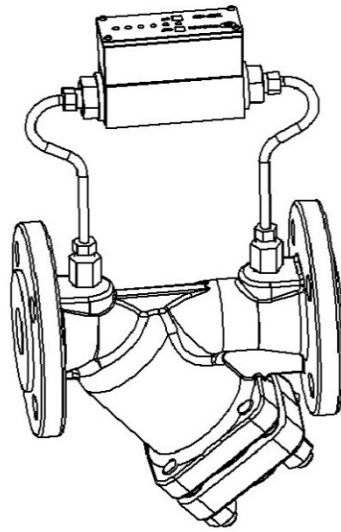

5. Dimensions of the indicator

DIMENSIONS OF THE INDICATOR

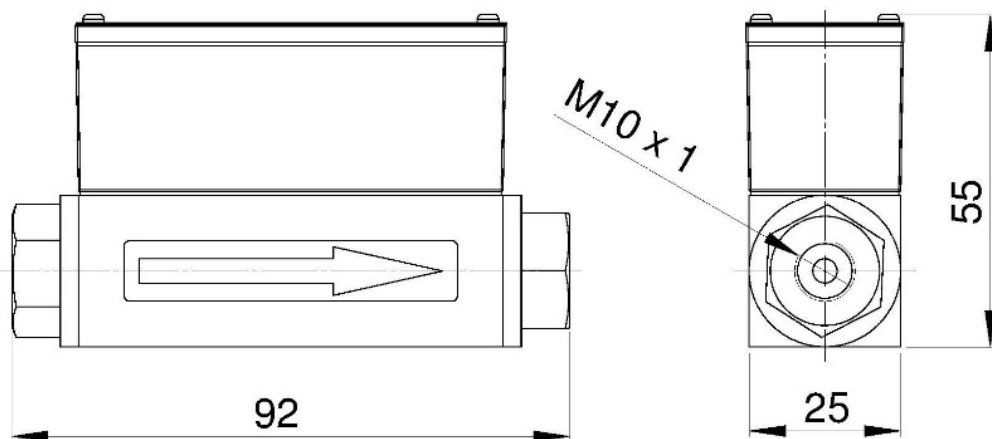

12. WARRANTY TERMS

- ZETKAMA grants quality warranty with assurance for proper operation of its products, providing that assembly of them is done according to the users manual and they are operated according to technical conditions and parameters described in ZETKAMA's catalogue cards. Warranty period is 18 months starting from assembly date, however not longer than 24 months from the sales date.
- warranty claim does not cover assembly of foreign parts and design changes done by user as well as natural wear.
- immediately after detection the user should inform ZETKAMA about hidden defects of the product
- a claim should be prepared in written form.