

Direct Mount 3-Piece Ball Valve

KHD-35 (Formerly AC-305)

Installation, Operation, & Maintenance Manual

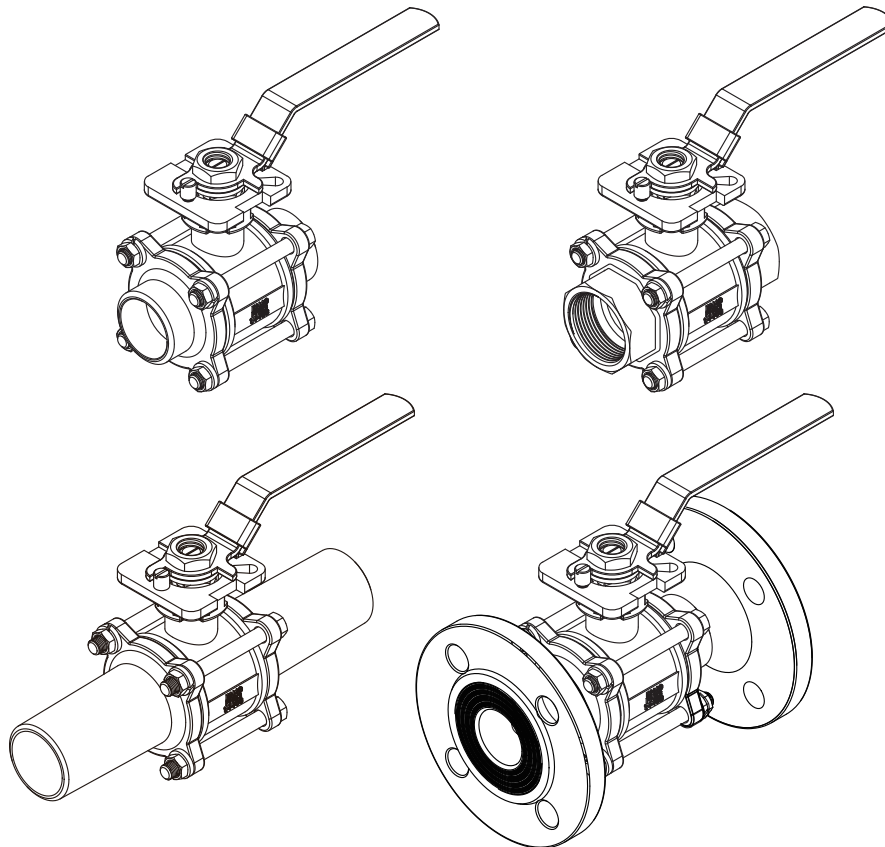

Table of Contents

I	Introduction	
	1.1 Contact Information	3
	1.2 General Notes	3
	1.3 Precautions and Warnings	3
	1.4 Storage	4
II	Installation	
	2.1 General Notes	4
	2.2 Installation of Ends	5
	2.3 Pneumatic and Electrical Connections	5
III	Operation	
	3.1 Handling	7
	3.2 Cleaning	7
	3.3 Manual Operation	7
	3.4 Remote Operation	7
	3.5 Technical Data	7
IV	Maintenance	
	4.1 General Notes	8
	4.2 Maintenance Frequency	8
	4.4 Reassembly	9
	4.5 Troubleshooting	9
	4.6 Technical Data and Product Information	10

Chapter I

Introduction

The manual is provided to ensure proper installation, operation & maintenance for KHD-35 Direct Mount 3-Piece Ball Valve, manufactured and supplied by KLINGER Die Erste Industry Co., Ltd. The valves are identified by marking on the body or on a name plate or both.

1.1 Contact Information

For information concerning warranties, or for questions pertaining to installation, operation or maintenance of KLINGER Die Erste products, contact:

KLINGER DIE ERSTE INDUSTRY CO., LTD.
5F-1, No.936, Sec. 4, Wen-Xin Road,
Taichung City, Taiwan 406

Phone: +886 4 22310059
Fax: +886 4 22360236
Email: sales@die-erste.com

To order replacement parts, contact KLINGER Die Erste sales at address listed above.

1.2 General Notes

The following instructions refer to KLINGER Die Erste KHD-35 Direct Mount 3-Piece Ball Valve as described in the KLINGER Die Erste current catalog.

Keep the protective covers in place until the valve is ready for installation. Valve performance depends upon prevention of damage to ball surface. After removing the cover make sure that the valve is completely open and free of obstructions, dirt, particles or any materials that may cause seat or seal damage.

Valves may contain a silicon-based lubricant for transportation, which aids in the assembly of the valve. Lubricant may be removed with a solvent if found objectionable. Alternatively valves can be ordered free of lubricants upon request.

Certain ferrous valves contain phosphate material, and are oil dipped during the course of manufacture. However, the processes used are completely non-toxic.

1.3 Precautions and Warnings

Choose the correct material of valve for different applications before obtaining the valve. The user should be aware of the operating situation, fluid properties, and the possible outcomes when implementing valves into the pipeline system. KLINGER Die Erste suggests that the user should make estimation beforehand.

Fluid undergoes property changes with respect to outside factors, particularly fluid left inside the sealed cavity. When temperature and pressure exceed allowable value, valve failure may occur. Despite the KHD-35 Direct Mount 3-Piece Ball Valve offers the pressure-relief function to prevent pressure buildups, users should be aware of that excessive pressure and temperature at nearby pipeline system can also cause valve failure as well.

KHD-35 Direct Mount 3-Piece Ball Valve are generally not recommend for throttling services, due to both fluid flow and ball leading edge may damage or deform the resilient ball seats, and consequently causing leakage problem. Further, high fluid velocity or the presence of solid particles in suspension will further reduce seat life in throttling applications.

Do not attempt to remove the bonnet from the body during operation, especially with the presence of high pressure in the pipeline system.

For safety concern, unstable fluid should not be used in the pipeline system, unless otherwise specified with the category III in Declaration of conformity.

NOTE:

Actuators and accessories are only discussed briefly. Please refer to individual manuals for further information on their IOM manuals.

CAUTION:

Before removing valve from pipeline, operator should be aware of that: media flowing through the valve may be corrosive, toxic, flammable, or of a contaminant nature. Where there is evidence of harmful fluids having flowed through the valve, the utmost care must be taken. It is suggested that the following safety precautions should be taken when handling valves.

- 1) Always wear eye shields.
- 2) Always wear gloves and footwear.

- 3) Wear protective headgear.
- 4) Ensure that running water is readily accessible.
- 5) Fire extinguisher must be obtainable if media is flammable.

Check the line gauge to ensure that no pressure is present at the valve. Ensuring media is released by operating valve slowly to the half open position. Ideally, the valve should be decontaminated when the ball is in the half open position.

These valves, when installed, have body connectors which form an integral part of the pipeline and the valve cannot be removed from the pipeline without being dismantled.

1.4 Storage

If the valves are not to be installed immediately, please store the valve carefully before installation, preferably indoors in a dry and clean place.

Also, the valve ports should be sealed by plastic caps to prevent dirt from entering and damaging inner parts.

All KLINGER Die ERSTE carbon steel are shipped from the factory with a phosphate coating on un-machined surfaces and with a rust preventative sprayed on machined surfaces. In addition, plastic end protectors are installed on both end connections for protection from damage and to prevent entrance of foreign materials into the valve. Valves received in the above condition and in their original shipping containers may be stored for up to one (1) year with no additional protection; provided they are stored indoors, above floor level, and in a low humidity atmosphere.

If valves are to be stored indoors for a longer period of time in a high (80% or greater) humidity atmosphere, it is suggested that each item be periodically inspected, inside and out, for rust and/or corrosion.

Note:

If the caps are missing, an inspection of the valve cavity is required. All foreign material must be removed. If cleaning of the valve is required, care must be taken as to the type of solvents used, particularly if the valve is to be connected to the line by welding.

Chapter II

Installation

Flush the pipeline carefully before installing the valve. The particles of dirt or debris or welding may damage the ball sealing surface and seats. Also, before installing, check all valve and mating flanges to ensure gasket surfaces are free from defects.

⚠ CAUTION:

Do not exceed the valve performance limitation.

⚠ CAUTION:

Before installing, make sure the line pressure has been relieved, and any hazardous fluids have been drained or purged from the system.

2.1 General Notes

1) Direction

Standard KHD-35 ball valves are bi-directionally sealed unless otherwise specified.

Note:

If requested, valves with upstream hole in ball are one-way valves.

2) Position

The body, cap and gasket are in the connection area of ball valve and pipeline. The bear weight ability and gradient are very important to the pipe installation. Do not make the pressure from the pipeline, and stress to concentrate on the connecting area of body and cap. Ball, seat, and stem will be damaged. Consequently, deformation and leakage may occur.

Note:

Most of the valves do not restrict the flow direction when installing the KHD-35. However, KLINGER Die Erste suggests vertical or horizontal position to maximize sealing and reduce the accumulation. In the case of vertical installation, upstream pressure should be located above, since in the floating ball design, the ball helps the sealing effects.

3) Fittings

Select the correct size of fittings according to the pipeline specification. Mating the valve to the pipeline adequately with appropriate bolts. Do not attempt to correct pipeline misalignment by means of

flanged bolting.

Note:

Over tightening of any side may cause leakage.

4) Systems hydrostatic test

Before delivery, valves are tested 1.5 times the allowable pressure at ambient temperature in OPEN position. However, after installation, the piping system may subject to system tests, as condition not to exceed the marking pressure.

5) Pre-Installation Wash

Before the valve installation, clean the pipeline system to remove any foreign deposits by water. Clean the connecting flanged end surfaces as well to ensure tight sealing.

2.2 Installation of Ends

1) Flanged End

1. Before installing the valves, make sure the flanges and the pipe are free from grit, dirt or burrs.
2. The flanges must be aligned and parallel with the correct distance to allow the valve face-to-face dimension and gaskets to fit between.
3. Tighten the flange bolts in a crossover pattern, with a torque values determined by the gasket manufacturer, other variables like gasket type and material, bolt, flange and lubricant affect the tightening torque values.
4. Note that the bolts tightening must be uniform in order to create a parallel movement of the two flanges and uniform deformation of the gasket in between them.
5. Before pressure testing the valves, bring the valves to the half OPEN position to ensure pressure reaches the stem seals and to avoid unnecessary loading of the seats. Fail-to-close actuated valves should be brought to the half-OPEN position.

Note:

Do not fasten supports to the flange bolting or the actuator.

2) Threaded Ends

It is not necessary to disassemble threaded end valves before installation. Note that the taper threaded fitting should not be over tightened.

3) Welded Ends

The general installation guides are the following:

1. With the valve in the OPEN position, remove the body bolts.
2. Separate the caps from the body and remove the seats and body seals. Take care not to damage them.
3. Rotating the ball into partially OPEN position will assist in removing the seats.
4. Position the ball to CLOSED to remove it from the body.
5. With the soft components removed, loosely reassemble the valve.
6. Tack-weld the caps to pipeline.
7. Complete the welding carefully to avoid welding splatter onto the exposed end faces.
8. Do not scratch or cut the seats and sealing surfaces of the valve. Damages of the soft components may cause valve leakage.
9. When cooled, clean the pipe faces and the reassemble the valve center section.
10. Slip the center section between the pipe ends carefully not to score the end faces.
11. Install the body bolts and tighten.

⚠ CAUTION:

DO NOT heat the center section over 150°C (300°F)

NOTE:

Valve what will be welded directly to the line must be in fully OPEN position to protect the ball and seats from excessive temperatures during the welding procedures.

2.3 Pneumatic and Electrical Connections

When installing the actuator, make sure that the valve-actuator combination functions properly. The valve OPEN and CLOSED position are indicated by a groove at the top of valve shaft. See Figure 2.1.

If possible, install the valve so that the actuator can be disconnected without removing the valve from the piping.

Please refer to the appropriate instruction manual shipped with the automation devices for the installed actuator, positioner, filter/regulator, solenoid, and/or limit switches.

When making pneumatic connections, it is recommended that PTFE tape or paste is used on threaded joints, unless otherwise specified by the components instruction manual. The pneumatic supply, such as dry air or nitrogen, should be clean. When making electrical connections, wiring of components should be in accordance with any and all applicable local and national codes and standards.

Before installing the actuator, use an adjustable wrench to manually rotate the valve stem several times. This rotation breaks the torque that may have built up during long-term storage.

Chapter III

Operation

For manual operation, shift the handle in clockwise direction for CLOSED and counter-clockwise for OPEN.

If the handle is in parallel position with the flow direction, the valve is OPEN. If the handle is in right angle position with the flow direction, the valve is CLOSED.

When installing actuator or the valve is operated with removable handle, the user should ensure the position of the valve whether open or close. The line on the top of the stem indicates whether the valve is in OPEN or in CLOSED position. Figure 2.1 and the below Figure 3.1 provides the visual understanding of above explanation.

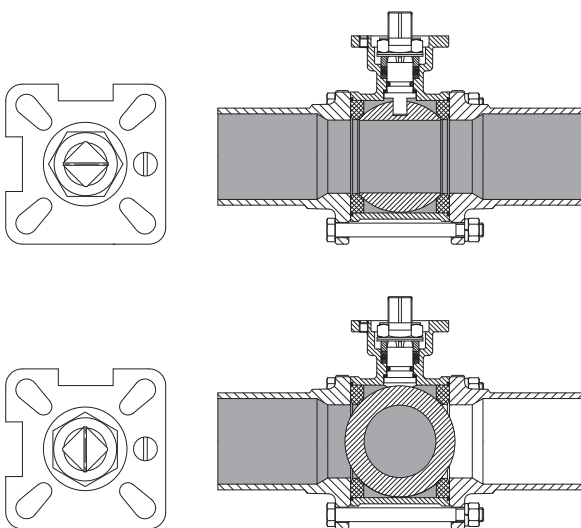

Figure 2.1 The top graph indicates an OPEN valve, and the bottom one represents a CLOSED valve

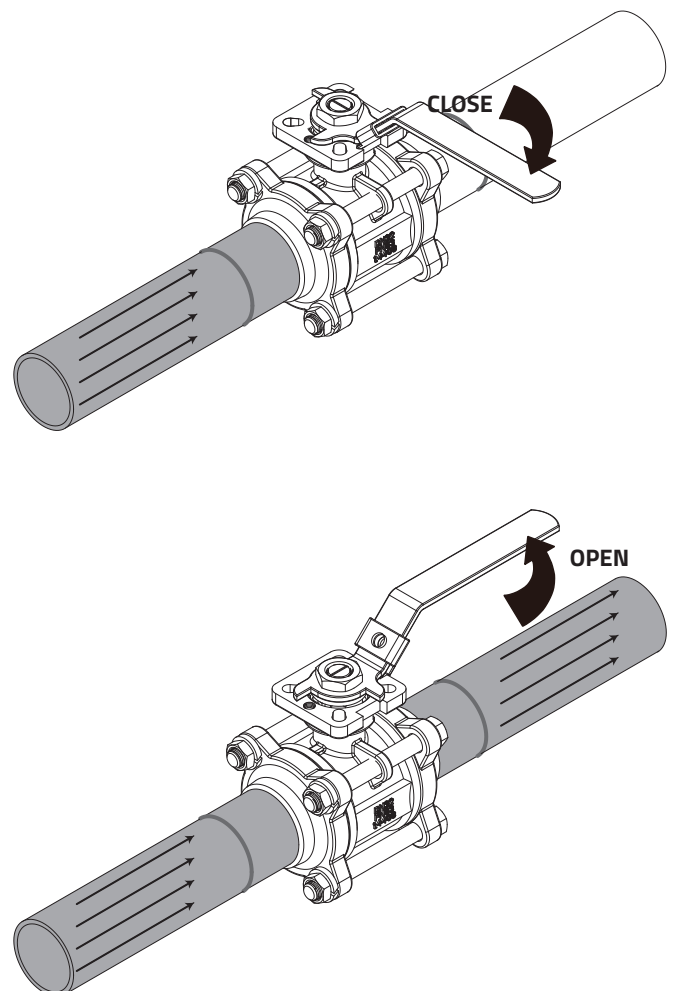

Figure 3.1 Rotation Direction for CLOSED and OPEN position

3.1 Handling

During the ball valve installation, it must follow the procedure to handle at the both side of the bodies. If using cable for big size valve, make sure the cable must be strong enough to ensure the safety during the installation.

Never lift the valve package by the actuator, positioner, limit switch or their piping. The Valve damage or personal injury may occur from falling parts.

3.2 Cleaning

Even though the valves were transported under a clean environment, operator must check if there is any foreign body or dusts inside the bore. If yes, clean the valve before installation. Operator may clean the valves by water, compression air, or steam. However, valve automation devices shall be cleaned only with water or steam, using compression air to clean the valve automation devices is strictly prohibited. For cleaning operation, first step is put the valve bore perpendicular to the ground and clean, ensure all the dusts are removed from the bore. The second step is to check and clean all the connecting pipe bore and connection area. No flush, rust and foreign bodies are allowed to avoid the blocking and leakage.

3.3 Manual Operation

KLINGER Die Erste KHD-35 Direct Mount 3-Piece Ball Valve have ¼ turn operation opening in a counter-clockwise direction. When the handle is positioned across the pipeline, this indicates that the valve is closed. When the handle is positioned parallel with the pipeline, this indicates the valve is open.

3.4 Remote Operation

Where manual operation is not required, valves may be automated for remote operation, instrument controls etc. KLINGER Die Erste offers a wide range of pneumatic and electric actuators for different working conditions.

When an actuator is used, no stop plate is fitted to the valve since end stops are an integral part of the actuator. Operation will be in accordance with KLINGER Die Erste Installation, Operation and Maintenance Instructions for the relevant actuator.

⚠ CAUTION:

Keep hands, other parts of the body, tool and other objects out of the open flow port. Leave no foreign object inside the pipeline. When the valve is actuated, the ball segment act as a cutting device. Also, the segment position may change when the valve is moved. The failure may result in damage or personal injury.

3.5 Technical Data

Table 3.1 Break Torque at room temp

Size		Break Torque @ 27°C (81°F)	
DN	Inch	N.m	lbf.in
8	1/4"	6	53
10	3/8"	8	71
15	1/2"	11	97
20	3/4"	14	124
25	1"	18	159
32	1-1/4"	28	248
40	1-1/2"	45	398
50	2"	52	460
65	2-1/2"	67	593
80	3"	95	841
100	4"	125	1106

Table 3.2 Flow Coefficient

Size		Kv	Cv
DN	Inch		
8	1/4"	6	7
10	3/8"	7	8.3
15	1/2"	21	24
20	3/4"	41	47
25	1"	70	81
32	1-1/4"	114	132
40	1-1/2"	175	202
50	2"	325	376
65	2-1/2"	555	642
80	3"	779	901
100	4"	1374	1588

Chapter IV

Maintenance

⚠ CAUTION:

Do not dismantle the valve or remove it from the pipeline while the valve is pressurized.

4.1 General Notes

With Self-wipe ball, seats, and pressure equalizing slots, KLINGER Die Erste valves have a long, trouble-free life, and maintenance is seldom required. However, when necessary, valves may be refurbished, using a minimal number of components, none of which require machining. The valves are designed for easy service and assembly in the field.

Before maintenance, user should check availability of the service kits for KHD-35 Direct Mount 3-Piece Ball Valve. We strongly recommend using the genuine service kit produced directly from the manufacture facility. For more information, please contact your KLINGER Die Erste representatives. Service kits may be available locally; however, KLINGER Die Erste is not responsible for any of the valve damage caused by using non-genuine spare parts.

4.2 Maintenance Frequency

The maintenance frequency is determined based upon the application of the valve. User should consider the following factors when determining the maintenance time interval: fluid type, flow velocity, operation frequency, pressure and temperature.

Note:

For the KHD-35 Direct Mount 3-Piece Ball Valve, KLINGER Die Erste recommends inspecting the valve at least every (1) year.

Note:

Please use the original spare parts to ensure the valve functions well.

Note:

When sending back the valve to KLINGER Die Erste for investigation, do not disassemble it. Clean the valve carefully and flush the valve internals. If possible, inform us about the medium used in the valve.

4.3 Disassembly

⚠ CAUTION:

Pipeline and valve must be depressurized by shutting off the valve and bleed line, cycle the valve once and leave it half open to relieve the pressure from the body cavity.

1. Depressurized and empty the seal up fluid in the cavity before disassembly. Be cautious of the fluid inside the valve as they can be poisonous and flammable.
2. Valve shall be positioned vertically by resting body side on clean ground surface, preferably covered with rubber sheet. Shift the HANDLE (17) so the valve is in the partial close position; otherwise, the valve ball cannot be removed from the bore later.
3. Remove the HANDLE (17) by removing the HANDLE NUT (15). Remove the HANDLE WASHER (14) and LOCK SADDLE (11).
4. Remove the STEM NUT (12), BELLEVILLE WASHER (10) and GLAND (9) from the stuffing box.
5. Loosen the BODY NUTS (21) in diagonal pattern and remove one of CAPS (2) from the BODY (1).
6. Remove and replace the BODY SEAL (5) from the CAPS (2).
7. Remove the BALL SEAT (4) and then the BALL (3) from the Body.
8. Remove the other CAP (2), BODY SEAL (5) and BALL SEAT (4).
9. Remove the STEM (6) from the side of body by pushing it from the top.
10. Remove and replace the THRUST WASHER (7) and O-RING (22) from the Stem.
11. Replace a new STEM PACKING (8).
12. All the components should be stored in a clean place.

Note:

Damaged internals to be replaced by KLINGER Die Erste repair kits only.

4.4 Reassembly

Before reassembly, inspect the valve for any damage on body and all internals. Damaged internals can be replaced by genuine KLINGER Die Erste valve part from the service kit.

1. Follow the same step as point 1 mentioned in Section 4.3.
2. Apply suitable coat to BODY BOLTS (19) to prevent from corrosion.
3. Insert the THRUST WASHER (7) thru the STEM (6) and O-RING (22) in position on the STEM (6).
4. Install the STEM (6) from inside the BODY (1).
5. Align STEM (6) parallel with the body bore.
6. Gently slide the BALL (3) over the STEM (6) so that the stem and the ball are interlocked.
7. Insert BODY SEATS (4) in position on both side of BODY (1).
8. Position the BODY SEALS (5) with the BODY (1) and position BODY BOLTS (19).
9. Assemble the valve by putting Caps (2) to two side of BODY (1) together with the center piece, and tighten the BODY NUTS (21).
10. Insert the STEM PACKING (8), GLAND (9) and BELLEVILLE WASHER (10) sequentially into the STEM (6) from the top.
11. Tighten the STEM NUT (12). Ensure proper locking of Stem with Locking LOCK SADDLE (11) and HANDLE WASHER (14) as applicable.
12. Place the HANDLE (17) on the STEM (6) and tighten the HANDLE NUT (15).
13. Ensure smooth operation of valve during opening and closing.

Valve leaking from body and cap joint (External Leakage)	Damaged or breakage of gasket	Replace gaskets
	Relaxation of studs due to gasket creep	Re-tighten the studs evenly
Valve too hard to operate	Damaged seats	Replace seats
	High pressure	Confirm the pressure rating
	Foreign particles in valve	Clean the internals

The torque for tightening studs:

1/4"~3/8":	12 N.m (including 20% safety factor)
1/2"~3/4":	17 N.m
1"	: 24 N.m
1-1/4"	: 30 N.m
1-1/2"	: 36 N.m
2"	: 54 N.m
2-1/2"	: 60 N.m
3"	: 72 N.m
4"	: 84 N.m

4.5 Troubleshooting

The following table lists the possible malfunctions.

Table 4.3 Troubleshooting Table

Symptom	Possible fault	Actions
Leakage through a closed Valve (Internal Leakage)	Damaged ball surface	Replace the ball
	Damaged seats	Replace seats
	Ball might not be fully closed	Realign the ball
Irregular ball movement	Fluid accumulated on the surface.	Flush the ball from inside
	Ball or seat damaged	Clean or replace the ball or seat
Valve leaking from stem (External Leakage)	Stem nut are loosened	Tighten the stem nut
	Parts are worn or damaged	Replace the necessary parts

4.6 Technical Data and Product Information

KHD-35

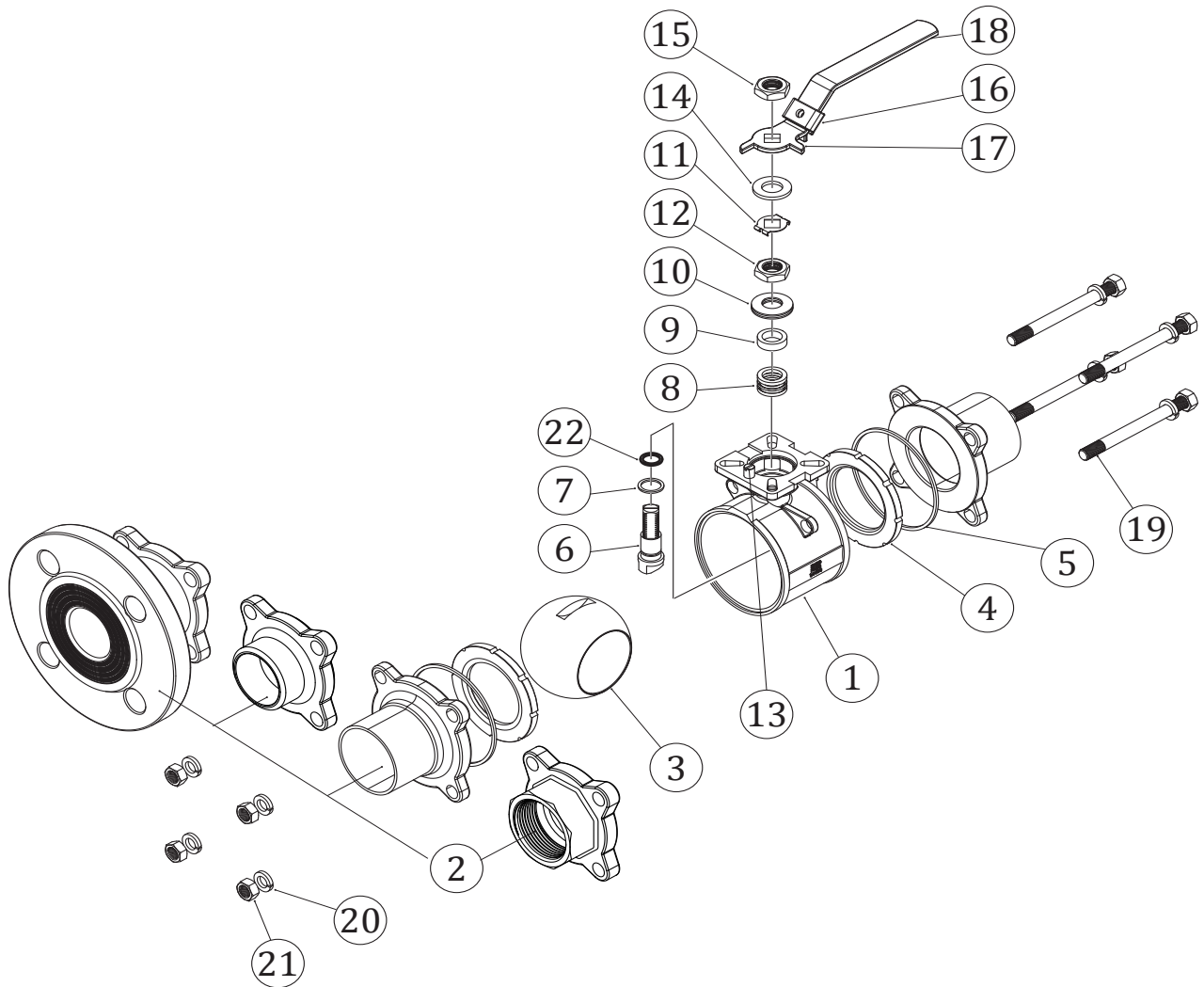

NO	PART NAME	MATERIAL
1	BODY	1.4408
2	CAP	1.4408
3	BALL	1.4408
4	BALL SEAT	MG1241
5	BODY SEAL	MG1241
6	STEM	SS316
7	THRUST WASHER	MG1241
8	STEM PACKING	PTFE
9	GLAND	SS304
10	BELLEVILLE WASHER	SS304
11	LOCK SADDLE	SS304

NO	PART NAME	MATERIAL
12	STEM NUT	SS304SS304
13	STOP PIN	SS304
14	HANDLE WASHER	SS304
15	HANDLE NUT	SS304
16	LOCKING DEVICE	SS304
17	HANDLE	SS304
18	HANDLE SLEEVE	PLASTIC
19	BODY BOLT	SS304
20	BODY WASHER	SS304
21	BODY NUT	SS304
22	O-RING	VITON