

## DIRECT-MOUNT 3-PC BALL VALVE

### Model: Series AC-35 (Formerly AC-305MF)

SIL3 Capable

#### • Features

- Square stem and twin ISO 5211 mounting pad allow easy automation
- Self-adjusting stem packing with Belleville washers minimizes need to re-tighten packing
- Chevron stem packing reduces wear and increases sealing performance
- 3-piece swing-out design enables in-line maintenance
- Blowout-proof stem
- Anti-static device(optional)
- V-port options available in 10°, 30°, 60°, 90° for control applications
- Certified according to PED 2014/68/EU
- EN 10204-3.1 Material Certificate is complementary

#### • Body Material

- ASTM CF8M, CF8, WCB
- DIN 1.4408, 1.4308, 1.0619

#### • Size Range

- 1/4" - 4" (DN8~DN100)

#### • Pressure Rating

- 1000PSI (PN63)

#### • End Connection

- Threaded
- Buttweld, long buttweld
- Socketweld
- Combination of end connections also available

#### • Temperature Range

- 4°F to 350°F (-20°C to 180°C) with PTFE seats
- 4°F to 400°F (-20°C to 200°C) with MG1241 seats

#### • Inspection Standard

- API 598, ISO 5208 or EN 12266-1

#### Materials List:

NO.	PART NAME	MATERIAL
1	BODY	1.4408 / 1.0619
2	CAP	1.4408 / 1.0619
3	BALL	1.4408 / 1.4308
4	BALL SEAT	PTFE
5	BODY SEAL	PTFE
6	STEM	SS316
7	THRUST WASHER	PTFE
8	STEM PACKING	PTFE
9	GLAND	SS304
10	BELLEVILLE WASHER	SS304
11	LOCK SADDLE	SS304
12	STEM NUT	SS304
13	STOP PIN	SS304
14	HANDLE WASHER	SS304
15	HANDLE NUT	SS304
16	LOCKING DEVICE	SS304
17	HANDLE	SS304
18	HANDLE SLEEVE	VINYL
19	BODY BOLT	SS304
20	BODY BOLT WASHER	SS304
21	BODY BOLT NUT	SS304
22	O-RING	VITON

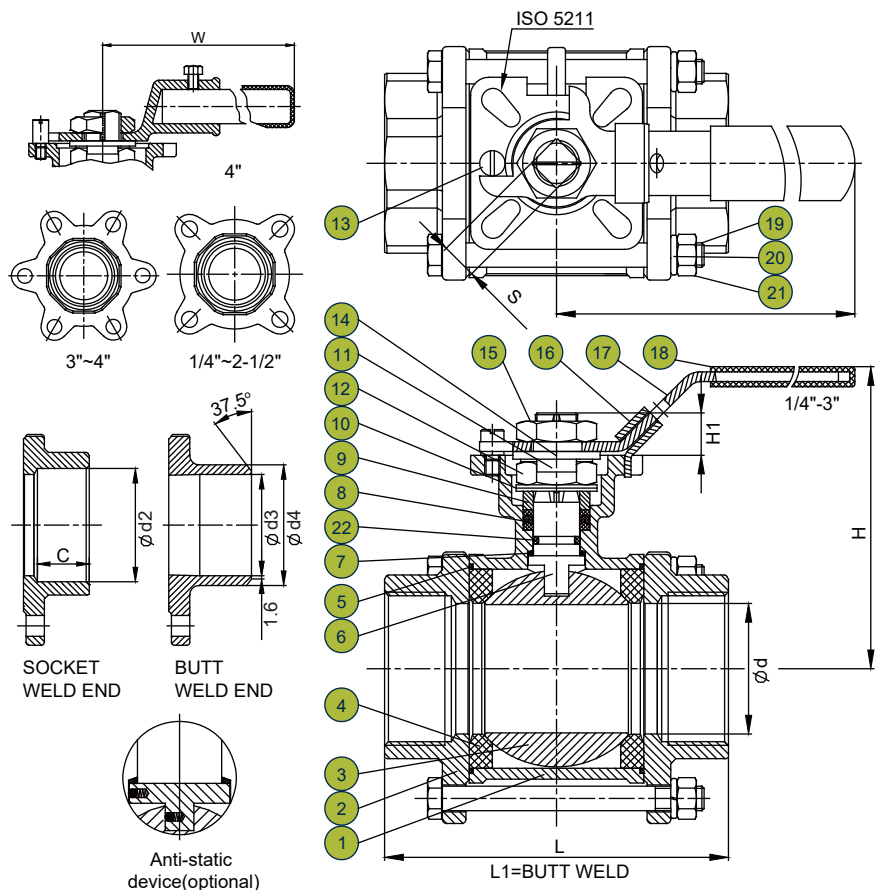

# DIRECT-MOUNT 3-PC BALL VALVE

## Model: Series AC-35 (Formerly AC-305MF)

SIL3 Capable

### Dimensions (mm):

SIZE IN DN	d	L	L1	H	W	H1	S	d2	d3	d4	C	ISO 5211	TORQUE in-lbs NM	
1/4"	8	11.6	64	-	74	123	9	9	14.1	-	-	14	F03/F04	53 6
3/8"	10	12.7	64	-	74	123	9	9	17.6	-	-	15.5	F03/F04	71 8
1/2"	15	15	64	75	74	123	9	9	21.7	16	21.3	16	F03/F04	97 11
3/4"	20	20	81.5	90	78	123	9	9	27.1	20	26.7	18.5	F03/F04	124 14
1"	25	25	90	100	89	153	11	11	33.8	25	33.6	25.9	F04/F05	159 18
1-1/4"	32	32	112.5	110	94	153	11	11	42.6	33.8	42.4	21	F04/F05	248 28
1-1/2"	40	38	126.5	125	110	183	14	14	48.7	39.5	48	26	F05/F07	398 45
2"	50	50	147	150	118	183	14	14	61.1	50.8	60.5	25.4	F05/F07	460 52
2-1/2"	65	65	163	190	161	246	17	17	76.9	62.7	76.1	31	F07/F10	593 67
3"	80	80	181	220	170	246	17	17	89.8	77.9	88.9	36	F07/F10	841 95
4"	100	100	228	270	202	395	22	22	115.5	100	114.2	43	F10/F12	1106 125

Note: Torque measured with PTFE seats at ambient temperature with no loading; safety factor is not included.

Size		Cv	Kv
Inch	DN		
1/4"	8	7	6.1
3/8"	10	8.3	7.2
1/2"	15	24	20.8
3/4"	20	47	40.7
1"	25	81	70.1
1-1/4"	32	132	114.2
1-1/2"	40	202	174.7
2"	50	376	325.2
2-1/2"	65	642	555.3
3"	80	901	779.4
4"	100	1588	1373.6

The upper table represents the Flow Coefficients (CV) and Flow Factor (Kv) for DIE ERSTE Series AC-305 ball valves. This number represents the volume of water at 60°F that will flow in US gallon per minute through a valve with a 1 lb/in<sup>2</sup> pressure drop across in the full open position. For Kv, it is the flow of water with temperature from 5°C - 30°C in cubic meters per hour (m<sup>3</sup>/h) with a pressure drop of 1 bar.

$$Cv = F \sqrt{\frac{SG}{\Delta P}}$$

The Cv value is dependent on flow rate, pressure drop, specific gravity. The larger the Cv value, the easier the fluid will flow within the valve. However, Cv value is easily affected by various factors, such as fluid type, fluid viscosity, saturated steam pressure.

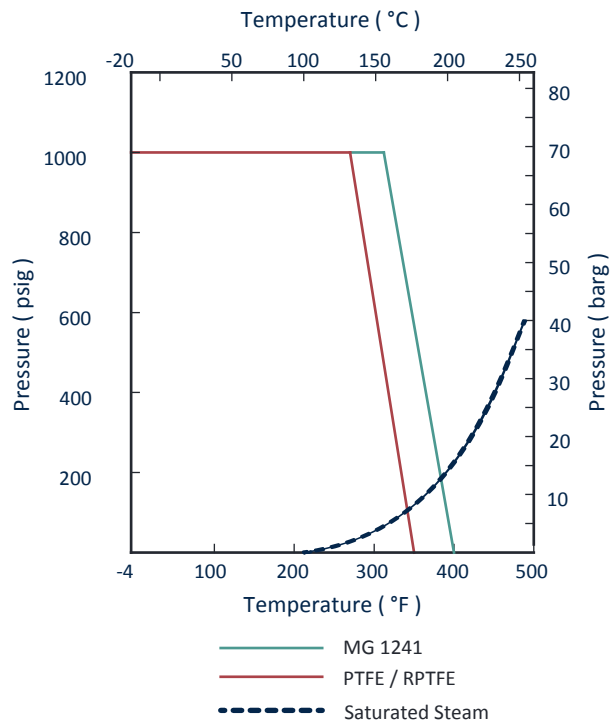

# DIRECT-MOUNT 3-PC BALL VALVE EXTENDED BUTT WELD END

## Model: Series AC-35-AS (Formerly AC-305MF-AS)

**SIL3 Capable**

### • Features

- Square stem and twin ISO 5211 mounting pad allow easy automation
- Self-adjusting stem packing with Belleville washers minimizes need to re-tighten packing
- Chevron stem packing reduces wear and increases sealing performance
- 3-piece swing-out design enables in-line maintenance
- Long buttweld end for easy welding
- Blowout-proof stem
- Anti-static device(optional)
- V-port options available in 10°, 30°, 60°, 90° for control applications
- Certified according to PED 2014/68/EU
- EN 10204-3.1 Material Certificate is complementary



### • Body Material

- ASTM CF8M, CF8, WCB
- DIN 1.4408, 1.4308, 1.0619

### • Size Range

- 1/4" - 4" (DN8~DN100)

### • Pressure Rating

- 1000PSI (PN63)

### • End Connection

- Threaded
- Buttweld, long buttweld
- Socketweld
- Combination of end connections also available

### • Temperature Range

- 4°F to 350°F (-20°C to 180°C) with PTFE seats
- 4°F to 400°F (-20°C to 200°C) with MG1241 seats

### • Inspection Standard

- API 598, ISO 5208 or EN 12266-1

### Materials List:

NO.	PART NAME	MATERIAL
1	BODY	1.4408 / CF8M / 1.0619
2	CAP	1.4404 / CF8M / 1.0619
3	BALL	1.4408 / CF8M / 1.4308
4	BALL SEAT	MG1241 / PTFE
5	BODY SEAL	MG1241 / PTFE
6	STEM	SS316
7	THRUST WASHER	MG1241 / TFM4215
8	STEM PACKING	PTFE
9	GLAND	SS304
10	BELLEVILLE WASHER	SS304
11	LOCK SADDLE	SS304
12	STEM NUT	SS304
13	STOP PIN	SS304
14	HANDLE WASHER	SS304
15	HANDLE NUT	SS304
16	LOCKING DEVICE	SS304
17	HANDLE	SS304
18	HANDLE SLEEVE	PLASTIC
19	BODY BOLT	SS304
20	BODY BOLT WASHER	SS304
21	BODY BOLT NUT	SS304
22	O-RING	VITON

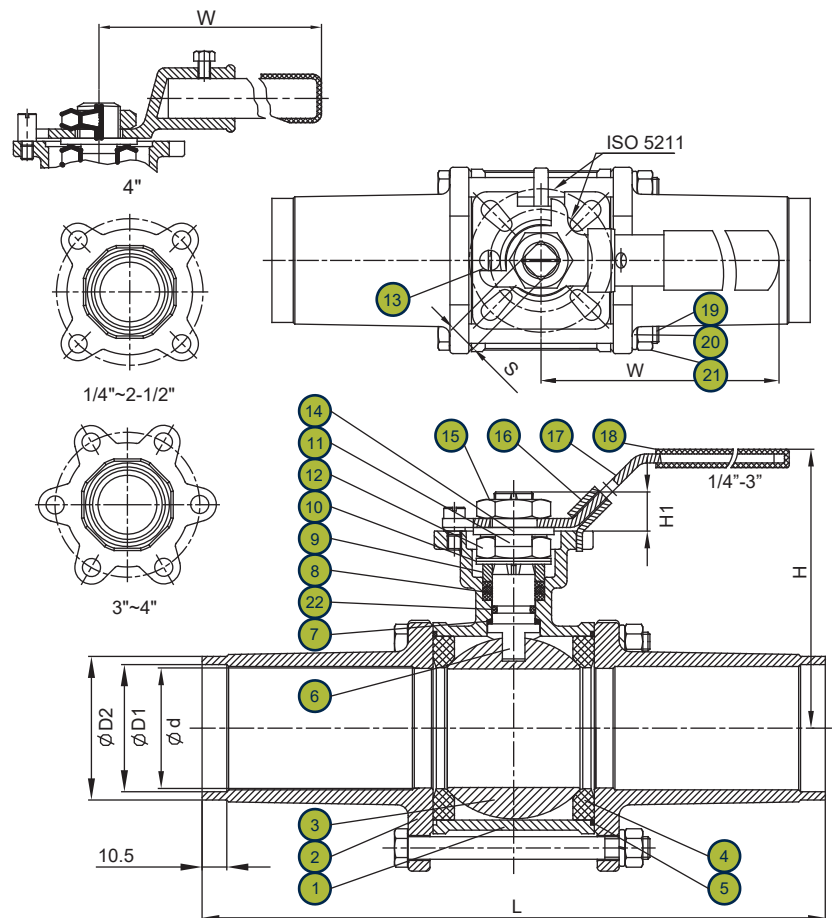

DIRECT-MOUNT 3-PC BALL VALVE EXTENDED BUTT WELD END  
**Model : Series AC-35-AS (Formerly AC-305MF-AS)**

**SIL3 Capable**

**Dimensions (mm):**

SIZE IN	DN	d	D1	D2	L	H	H1	S	W	ISO 5211	TORQUE	
											in-lbs	NM
1/4"	8	11.6	11.6	13.9	225	74	9	9	123	F03/F04	53	6
3/8"	10	12.7	15.2	17.2	225	74	9	9	123	F03/F04	71	8
1/2"	15	15	17.8	21	225	74	9	9	123	F03/F04	97	11
3/4"	20	20	23	27	225	78	9	9	123	F03/F04	124	14
1"	25	25	28.5	33.7	245	89	11	11	153	F04/F05	159	18
1-1/4"	32	32	37.2	42.2	255	94	11	11	153	F04/F05	248	28
1-1/2"	40	38	43	48.4	260	110	14	14	183	F05/F07	398	45
2"	50	50	54	61	275	118	14	14	183	F05/F07	460	52
2-1/2"	65	65	70	77	334	161	17	17	246	F07/F10	593	67
3"	80	80	82	90	354	170	17	17	246	F07/F10	841	95
4"	100	100	106	115	346	202	22	22	395	F10/F12	1106	125

Note: Torque measured with PTFE seats at ambient temperature with no loading; safety factor is not included.

Size		Cv	Kv
Inch	DN		
1/4"	8	7	6.1
3/8"	10	8.3	7.2
1/2"	15	24	20.8
3/4"	20	47	40.7
1"	25	81	70.1
1-1/4"	32	132	114.2
1-1/2"	40	202	174.7
2"	50	376	325.2
2-1/2"	65	642	555.3
3"	80	901	779.4
4"	100	1588	1373.6

The upper table represents the Flow Coefficients (CV) and Flow Factor (Kv) for DIE ERSTE Series AC-305 ball valves. This number represents the volume of water at 60°F that will flow in US gallon per minute through a valve with a 1 lb/in<sup>2</sup> pressure drop across in the full open position. For Kv, it is the flow of water with temperature from 5°C - 30°C in cubic meters per hour (m<sup>3</sup>/h) with a pressure drop of 1 bar.

$$Cv = F \sqrt{\frac{SG}{\Delta P}}$$

The Cv value is dependent on flow rate, pressure drop, specific gravity. The larger the Cv value, the easier the fluid will flow within the valve. However, Cv value is easily affected by various factors, such as fluid type, fluid viscosity, saturated steam pressure.

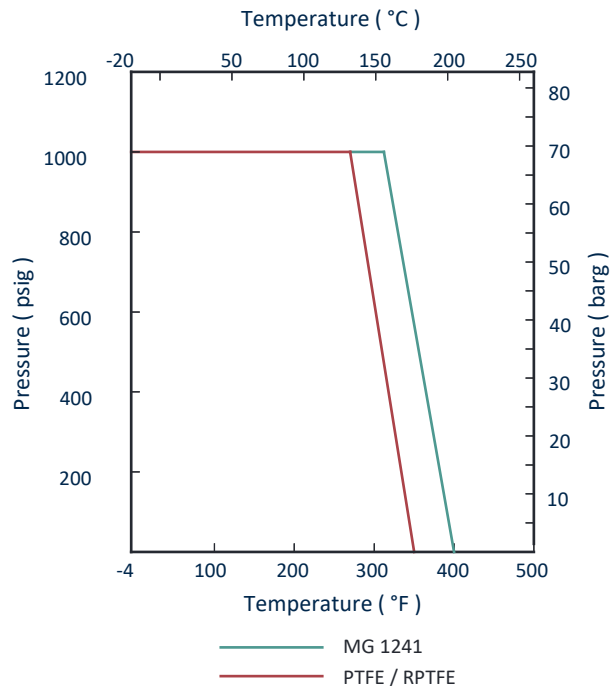

## DIRECT-MOUNT 3-PC BALL VALVE EXTENDED ORBITAL WELD END

### Model: Series AC-35-ASOR (Formerly ACOR-305MF-AS)

SIL3 Capable

#### • Features

- Square stem and twin ISO 5211 mounting pad allow easy automation
- Self-adjusting stem packing with Belleville washers minimizes need to re-tighten packing
- Chevron stem packing reduces wear and increases sealing performance
- 3-piece swing-out design enables in-line maintenance
- Long orbital weld end for ultra clean media
- Blowout-proof stem
- Anti-static device(optional)
- V-port options available in 10°, 30°, 60°, 90° for control applications
- Certified according to PED 2014/68/EU
- EN 10204-3.1 Material Certificate is complementary

#### • Body Material

ASTM CF8M, CF8, WCB  
DIN 1.4408, 1.4308, 1.0619

#### • Size Range

1/4" - 4" (DN8~DN100)

#### • Pressure Rating

1000PSI (PN63)

#### • End Connection

- Threaded
- Buttweld, long buttweld
- Socketweld
- Combination of end connections also available

#### • Temperature Range

- 4°F to 350°F (-20°C to 180°C) with PTFE seats
- 4°F to 400°F (-20°C to 200°C) with MG1241 seats

#### • Inspection Standard

API 598, ISO 5208 or EN 12266-1

#### Materials List:

NO.	PART NAME	MATERIAL
1	BODY	1.4408
2	CAP	1.4404
3	BALL	1.4408
4	BALL SEAT	MG1241
5	BODY SEAL	MG1241
6	STEM	SS316
7	THRUST WASHER	MG1241
8	STEM PACKING	PTFE
9	GLAND	SS304
10	BELLEVILLE WASHER	SS304
11	LOCK SADDLE	SS304
12	STEM NUT	SS304
13	STOP PIN	SS304
14	HANDLE WASHER	SS304
15	HANDLE NUT	SS304
16	LOCKING DEVICE	SS304
17	HANDLE	SS304
18	HANDLE SLEEVE	PLASTIC
19	BODY BOLT	SS304
20	BODY BOLT WASHER	SS304
21	BODY BOLT NUT	SS304
22	O-RING	VITON

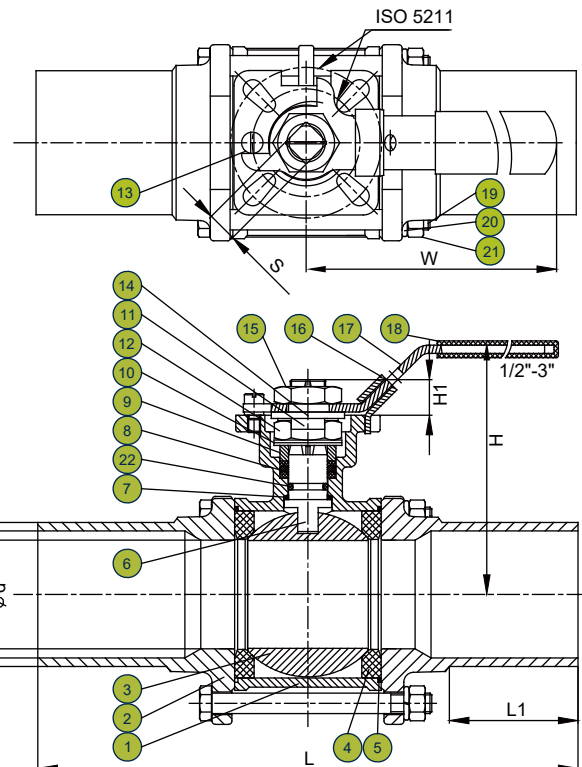
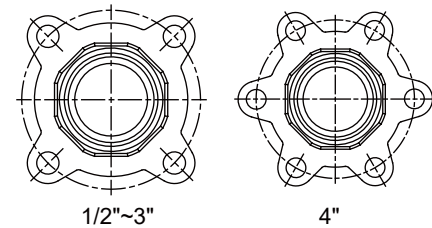
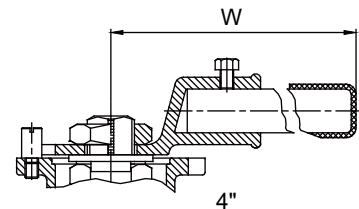

## DIRECT-MOUNT 3-PC BALL VALVE EXTENDED ORBITAL WELD END

### Model: Series AC-35-ASOR (Formerly ACOR-305MF-AS)

SIL3 Capable

#### Dimensions (mm):

SIZE IN	SIZE DN	d	D1	D2	L	L1	H	H1	S	W	T	ISO 5211	TORQUE in-lbs	TORQUE NM
1/2"	15	15	17.1	21.3	140	39	74	9	9	123	2.1	F03/F04	97	11
3/4"	20	20	22.7	26.9	140	32	78	9	9	123	2.1	F03/F04	124	14
1"	25	25	29.1	33.7	152	35	89	11	11	153	2.3	F04/F05	159	18
1-1/4"	32	32	37.4	42.4	165	33.5	94	11	11	153	2.5	F04/F05	248	28
1-1/2"	40	38	43.3	48.3	190	43.5	110	14	14	183	2.5	F05/F07	398	45
2"	50	50	54.3	60.3	203	40.5	118	14	14	183	3	F05/F07	460	52
2-1/2"	65	65	69.1	76.1	254	54	161	17	17	246	3.5	F07/F10	593	67
3"	80	80	81.9	88.9	280	58	170	17	17	246	3.5	F07/F10	841	95
4"	100	100	107.3	114.3	317	59	202	22	22	395	3.5	F10/F12	1106	125

Note: Torque measured with PTFE seats at ambient temperature with no loading; safety factor is not included.

Size		Cv	Kv
Inch	DN		
1/4"	8	7	6.1
3/8"	10	8.3	7.2
1/2"	15	24	20.8
3/4"	20	47	40.7
1"	25	81	70.1
1-1/4"	32	132	114.2
1-1/2"	40	202	174.7
2"	50	376	325.2
2-1/2"	65	642	555.3
3"	80	901	779.4
4"	100	1588	1373.6

The upper table represents the Flow Coefficients (CV) and Flow Factor (Kv) for DIE ERSTE Series AC-305 ball valves. This number represents the volume of water at 60°F that will flow in US gallon per minute through a valve with a 1 lb/in<sup>2</sup> pressure drop across in the full open position. For Kv, it is the flow of water with temperature from 5°C - 30°C in cubic meters per hour (m<sup>3</sup>/h) with a pressure drop of 1 bar.

$$Cv = F \sqrt{\frac{SG}{\Delta P}}$$

The Cv value is dependent on flow rate, pressure drop, specific gravity. The larger the Cv value, the easier the fluid will flow within the valve. However, Cv value is easily affected by various factors, such as fluid type, fluid viscosity, saturated steam pressure.

