

Instruction and Operating Manual

Electro-Pneumatic Positioner EPL / EPR Series



<VER 1.5>

Contents

1. Safety Instructions.....	3
2 Description.....	7
3 Principle of Operation.....	7
4 Specifications.....	8
5 Part Numbering System (order code).....	9
6 Descriptions on Nameplates.....	10
7 Internal Views.....	10
7.1. EPL Positioner.....	10
7.2. EPR Positioner.....	11
8 Installation.....	11
8.1. Mounting of EPL Positioner.....	11
8.1.1. Mounting and Attaching Feedback Lever.....	11
8.1.2. Position of Span Adjuster According to Actuator Type (RA or DA).....	12
8.2. Mounting of EPR Positioner.....	12
8.2.1. Mounting with NAMUR type.....	12
8.2.2. Mounting with Fork Lever Type.....	13
8.2.3. Adjustment of Cam and Indicator.....	14
9 Air Connections.....	15
9.1. EPL Positioner.....	15
9.2. EPR Positioner.....	15
10 Electrical Connections.....	16
10.1. General Wiring.....	16
10.2. Wiring for Intrinsic Safety Ex ia IIC T6.....	16
10.2.1. Connection to Terminals.....	16
10.2.2. Connection to Cable Gland.....	17
10.3. Wiring for Flameproof Ex dmb IIC T6/T5, Ex dmb IIB T6, Eex md IIB T5.....	18
10.3.1. Connection to Cable Gland.....	18
11 Setting of Span and Zero.....	19
12 Position Transmitter and Limit Switches.....	19
12.1. Position Transmitter (4 – 20mA output signal).....	20
12.1.1. Board View.....	20
12.1.2. Specifications.....	20
12.1.3. With multi-meter tester.....	21
12.2. SPDT Mechanical Limit Switches (open / close).....	21
13 Optional Restricted Pilot Valve Orifice.....	21
14 Troubleshooting Tips.....	22
15 Dimensions.....	23
15.1. EPL Positioner.....	23
15.2. EPR Positioner.....	24



1-1 Safety Instructions

These safety instructions are intended to prevent hazardous situations and/or equipment damage. These instructions indicate the level of potential hazard with the labels of **“Caution,” “Warning”** or **“Danger.”** They are all important notes for safety and must be followed in addition to International Standards (IEC) Note 1), and other safety regulations.

Note 1)	IEC 60079-0 : 2007	EN 60079-0 : 2009	EN 13463-1 : 2009
	IEC 60079-1 : 2007	EN 60079-7 : 2007	
	IEC 60079-11 : 2006	EN 60079-11 : 2007	EN 13463-5 : 2010
	IEC 60079-26 : 2004	EN 60079-26 : 2004	



Caution

Caution indicates a hazard with a low level of risk which, if not avoided, could result in minor or moderate injury.



Warning

Warning indicates a hazard with a medium level of risk which, if not avoided, could result in death or serious injury.



Danger

Danger indicates a hazard with a high level of risk which, if not avoided, will result in death or serious injury.



Warning

1. The compatibility of the product is the responsibility of the person who designs the equipment or decides its specifications.

Since the product specified here is used under various operating conditions, its compatibility with specific equipment must be decided by the person who designs the equipment or decides its specifications based on necessary analysis and test results. The expected performance and safety assurance of the equipment will be the responsibility of the person who has determined its compatibility with the product. This person should also continuously review all specifications of the product referring to its latest catalogue information, with a view to giving due consideration to any possibility of equipment failure when configuring the equipment.

2. Only personnel with appropriate training should operate machinery and equipment. The product specified here may become unsafe if handled incorrectly.

The assembly, operation and maintenance of machines or equipment including our products must be performed by an operator who is appropriately trained and experienced.

3. Do not service or attempt to remove product and machinery/equipment until safety is confirmed.

1. The inspection and maintenance of machinery/equipment should only be performed after measures to prevent falling or runaway of the driven objects have been confirmed.

2. When the product is to be removed, confirm that the safety measures as mentioned above are implemented and the power from any appropriate source is cut, and read and understand the specific product precautions of all relevant products carefully.

3. Before machinery/equipment is restarted, take measures to prevent unexpected operation and malfunction.

4. Contact POWER-GENEX beforehand and take special consideration of safety measures if the product is to be used in any of the following conditions.

1. Conditions and environments outside of the given specifications, or use outdoors or in a place exposed to direct sunlight.

2. Installation on equipment in conjunction with atomic energy, railways, air navigation, space, shipping, vehicles, military, medical treatment, combustion and recreation, or equipment in contact with food and beverages, emergency stop circuits, clutch and brake circuits in press applications, safety equipment or other applications unsuitable for the standard specifications described in the product catalogue.

3. An application which could have negative effects on people, property, or animals requiring special safety analysis.

4. Use in an interlock circuit, which requires the provision of double interlock for possible failure by using a mechanical protective function, and periodical checks to confirm proper operation.



1-2 Safety Instructions



Caution

1. The product is provided for use in manufacturing industries.

The product herein described is basically provided for peaceful use in manufacturing industries. If considering using the product in other industries, consult POWER-GENEX beforehand and exchange specifications or a contract if necessary. If anything is unclear, contact your nearest sales branch.

Limited warranty and Disclaimer/Compliance Requirements

The product used is subject to the following "Limited warranty and Disclaimer" and "Compliance Requirements". Read and accept them before using the product.

Limited warranty and Disclaimer

1. The warranty period of the product is 1 year in service or 1.5 years after the product is delivered.

Note 2)

Also, the product may have specified durability, running distance or replacement parts. Please consult your nearest sales branch.

2. For any failure or damage reported within the warranty period which is clearly our responsibility, a replacement product or necessary parts will be provided. This limited warranty applies only to our product independently, and not to any other damage incurred due to the failure of the product.

3. Prior to using POWER-GENEX products, please read and understand the warranty terms and disclaimers noted in the specified catalogue for the particular products.

Note 2) Vacuum pads are excluded from this 1 year warranty.

A vacuum pad is a consumable part, so it is warranted for a year after it is delivered.

Also, even within the warranty period, the wear of a product due to the use of the vacuum pad or failure due to the deterioration of rubber material are not covered by the limited warranty.

Compliance Requirements

1. The use of POWER-GENEX products with production equipment for the manufacture of weapons of mass destruction (WMD) or any other weapon is strictly prohibited.

2. The exports of POWER-GENEX products or technology from one country to another are governed by the relevant security laws and regulations of the countries involved in the transaction. Prior to the shipment of a POWER-GENEX product to another country, assure that all local rules governing that export are known and followed.



1-3 Precautions

Be sure to read before handling.

Operation



Warning

1. Do not operate the positioner outside the specified range as this may cause problems. (Refer to the specifications.)
2. Design the system to include a safety circuit to avoid the risk of danger should the positioner suffer failure.
3. Be sure that exterior lead-in wiring to the terminal box is based on the guidelines for explosion-protection of manufactory electric equipment when being used as a flame proof, explosion proof construction.
4. Do not remove terminal cover in a hazardous location while the power is on.
5. Covers for the terminal and body should be in place while operating.
6. When using as an intrinsically safe explosion-proof product, do not wire in a hazardous location while the power is on.



Caution

1. Do not touch the actuator or valve's oscillating section when supply pressure has been added, as this is dangerous.
2. Make sure fingers do not get caught when mounting and aligning the cam.
Cut off the pressure supply and always release the compressed air inside the positioner and actuator before performing this work.
3. Always use with the body cover unit mounted.
Moreover, the positioner may not meet degrees of protection IP66 depending on the body cover mounting conditions. In order to meet degrees of protection IP66, tighten threads using the proper tightening torques (2.8 to 3.0 N·m).
4. Always flush the pipe's inside before piping to ensure foreign objects such as machining chips do not enter the positioner.
5. The actuator opening may become unstable when using the booster relay.
6. Always use a ground connection to prevent noise from the input current and to prevent damage because of static electricity.
7. Use the pressure reading on the supplied pressure gauge as an indication.
8. The supplied pressure gauge's needle will malfunction if the pressure supply to the internal mechanism or positioner freezes. Ensure that the pressure gauge's internal parts do not freeze if using the pressure gauge in an operating environment with an ambient temperature of less than 0°C.

For users



Caution

1. Assemble, operate and maintain the positioners after reading the operation manual thoroughly and understanding the content.



1-4 Precautions

Be sure to read before handling.

Handling



Caution

1. Avoid excessive vibration or impact to the positioner body and any excessive force to the armature, as these actions may cause damage to the product. Handle carefully while transporting and operating.
2. If being used in a place where vibration occurs, using a binding band is recommended to prevent broken wires because of the vibration.
3. When exposed to possible moisture invasion, please take the necessary measures. For example, if the positioner is left onsite for long periods, a plug should be put in the piping port and a body cover unit fitted to avoid water penetration.
Take measures to avoid dew condensation inside the positioner if exposed to high temperature and humidity. Take enough measures against condensation especially when packing for export.
4. Keep magnetic field off the positioner, as this affects its characteristics.

Air Supply



Caution

1. Use only dehumidified and dust extracted clean compressed air as the air supply.
2. Use only dehumidified and dust extracted clean compressed clean air as the positioner contains extrafine orifices such as restrictor and nozzle.
Do not use a lubricator.
3. Do not use compressed air containing chemicals, organic solvents, salinity or corrosive gases, as this may cause malfunction.
4. When operating below the freezing point, protect the positioner from freezing.

Operating Environment



Caution

1. Do not operate in locations with an atmosphere of corrosive gases, chemicals, sea water, or where these substances will adhere to the regulator.
2. Do not operate out of the indicated operation temperature range as this may cause damage to electronic parts and seal materials to deteriorate.
3. Do not operate in locations where excessive vibration or impact occurs.
4. If the body cover is being installed in a place where the body cover is exposed to direct sunlight, the use of a standard body cover without the LCD window is recommended.



1-5 Precautions

Be sure to read before handling.

Maintenance



Warning

1. After installation, repair or disassembly, connect compressed air and conduct tests to confirm appropriate function and leakage.

Do not use the positioner when noise from the bleeder sounds louder compared with the initial state, or when it does not operate normally. If these occur, check immediately if assembled and mounted correctly.

Never modify electrical construction to maintain explosion-proof construction.



Warning-Potential electrostatic charging hazard

1. The non-metallic parts incorporated in the enclosure of this equipment may generate an ignition capable level of electrostatic charge. Therefore particularly when it used for applications that specifically require Group IIC, EPL Ga equipment, the equipment shall not be installed in a location where the external conditions are conducive to the build-up of electrostatic charge on such surfaces. Additionally, the equipment shall only be cleaned with a damp cloth.
2. The enclosure contains aluminium and is considered to present a potential risk of ignition by impact or friction. Care must be taken during installation and use to prevent impact or friction. Particularly, it must not be used for applications that specifically require EPL Ga equipment.



Caution

1. The insulation between an intrinsically safe circuit and a frame of the equipment is not capable of withstanding a 500V dielectric strength test as defined in Cl.6.3.12 of EN 60079-11:2007. This shall be taken into account during installation.
2. The earthing of enclosure is necessary to maintain Intrinsic Safety because the insulation between an intrinsically safe circuit and a frame of the equipment is not capable of withstanding a 500V dielectric strength test. There are two earthing points on the equipment. One is provided as an internal earthing point inside rear cover of the equipment for attaching of a cable screen. The other is provided as an external earthing point on the left side of the enclosure. Their cross-sectional areas should be capable of carrying the maximum possible current of the equipment. (Generally, an insulated wire having a cross-sectional area of at least 4mm² is recommended) The cable should be fitted with a split ring lock washer to minimize the risk of self-loosening and is of suitable construction for securing of conductors of cross sections up to 4mm².

2 Description

The EPL / EPR series are the intrinsically safe electro-pneumatic positioners that can be used in a hazardous area (Zone 1) and worked by a torque motor with 4-20mA input signals @ 24VDC power supply for operation of the control valves.

3 Principle of Operation

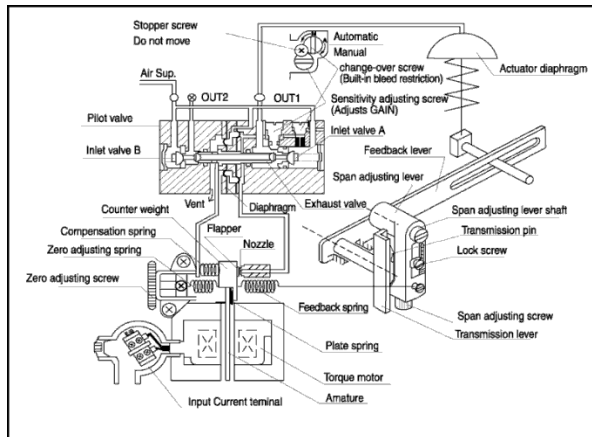

< EPL Positioner >

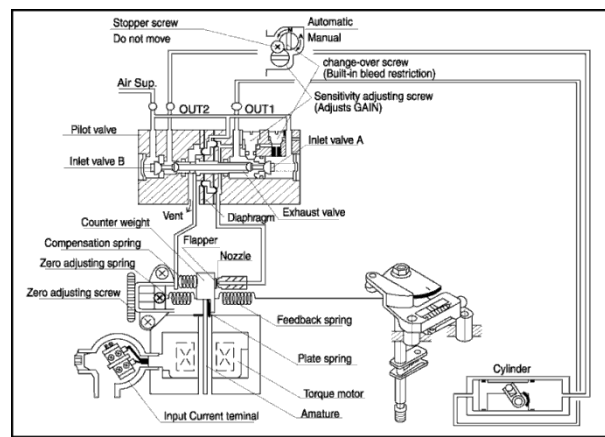

< EPR Positioner >

As the signal current from the controller increases, the plate spring of the torque motor works as a pivot. As the armature receives the rotary torque in the counter-clockwise direction, the counter-weight is pushed to the left, the clearance between the nozzle and the flapper will increase, and the nozzle back pressure will decrease. As a result, the exhaust valve of the pilot valve moves to the right, and the output pressure of OUT1 increases to move the actuator diaphragm.

The valve stem goes up or down by the movement of the actuator diaphragm, and the feedback spring lengthens or shortens by the movement of the feedback lever. The valve stem stays in the position where the spring force is balanced with the force generated by the input current in the torque motor. The compensation spring is for direct feedback of the motion of the exhaust valve and is connected to the counter weight to enhance the stability of the loop. The zero point is adjusted by changing the zero adjustment spring tension.

EPL / EPR Series

4 Specifications

	EPL		EPR	
	Linear Type (Lever Feedback)		Rotary Type (Cam Feedback)	
	Single	Double	Single	Double
Input Signal	4~20mA DC (Note. 1)			
Input Resistance	235 ± 15Ω			
Air Supply	Max. 7.0bar (100psi) free of oil, water, and moisture			
Standard Stroke / Angle	10 ~ 80mm (Note. 2)		60 ~ 100°	
Pneumatic Connections	Rc 1/4 (NPT 1/4)			
Electrical Connections	G 1/2 (NPT 1/2)			
Protection Class	IECEX / KC Ex dmb IIC T6/T5 ATEX Eex md IIB T5 IECEX / ATEX / KC Ex ia IIC T6 ATEX  KC / NEPSI Ex dmb IIB+H2 T6 IP66			
Ambient Temperature	Ex ia IIC : -20 ~ +70°C (T6) Ex dmb IIC: -40 ~ +70°C (T5), -40 ~ +55°C (T6) Operation Temp. -20 ~ +70°C (STANDARD) (Note 3)			
Pressure Gauge	Stainless steel			
Output Characteristics	Linear			
Linearity	Within ± 10 % FS	Within ± 15 % FS	Within ± 10 % FS	Within ± 15 % FS
Sensitivity	Within ± 02 % FS	Within ± 05 % FS	Within ± 0.5 % F.S	
Hysteresis	Within ± 1.0 % F.S			
Repeatability	Within ± 0.5 % F.S			
Air Consumption	5 LPM (Sup. 1.4kgf/cm ²)			
Flow Capacity	80 LPM (Sup. 1.4kgf/cm ²)			
Material	Aluminum Die-cast			
Weight	3.3 kg (with terminal box) 3.0 kg (without terminal box)		3.5 kg (with terminal box) 3.2 kg (without terminal box)	

Note: 1) 1/2 split range is available for 4-12mA input signal or 12-20mA input signal.

2) The feedback lever for up to 150mm is available.

3) Temperature option:

- Up to +120°C without feedback options
- Up to +85°C with feedback options
- Up to -40°C without feedback options

EPL / EPR Series

5 Part Numbering System (order code)

		EP	x	x	x	x	x	x	x	x	x	x
Actuator action	Linear type	L										
	Rotary type	R										
Protection Class:	KC / NEPSI flameproof Ex dmb IIB+H2 T6	F										
	IECEX / KC flameproof Ex dmb IIC T6/T5	D										
	ATEX flameproof Eex md IIB T5	A										
	IECEX / ATEX / KC intrinsically safe Ex ia IIC T6	I										
	Weatherproof to IP66	W										
Feedback Shaft	Linear type	10 ~ 40mm stroke		A								
		10 ~ 80mm stroke		B								
		Up to 150mm stroke		C								
	Rotary type	Fork lever M6x40L		F								
		NAMUR shaft (direct mounting)		N								
Gauge	6 bar (90psi)					1						
	10 bar (150psi)					2						
Pilot Valve Orifice	Standard(actuator volume over 180cm ³)						S					
	Small orifice (Φ1.0 or Φ0.7)(actuator volume 90~180cm ³)						M					
Position Feedback (only for weatherproof type)	None						N					
	Analog position transmitter (4-20mA output signal)						O					
	Smart position transmitter (4-20mA output signal) – only for EPR						S					
	2 x SPDT limit switch – only for EPR						L					
	2 x proximity sensor P&F NJ2-V3-N – only for EPR						P					
	O + L – only for EPR						M					
O + P – only for EPR						Q						
Connection Threads (pneumatic – electrical)	PT(Rc) 1/4 – PF(G) 1/2 (standard)							3				
	NPT 1/4 - NPT 1/2							4				
	Rc1/4 - M20 x 1.5							5				
Dome Indicator (only for EPR)	Flat indicator (standard)									N		
	Dome Indicator									D		
Operating Temperature	Ex ia IIC : -20 ~ +70°C (T6)										T	
	Ex dmb IIC: -40 ~ +70°C (T5), -40 ~ +55°C (T6)											
	Weatherproof: -20 ~ +70°C											
	+120°C (without feedback option)										H	
+85°C (with feedback option)												
-40°C (without feedback option)											L	
Mounting Bracket	None											N
	DIN / IEC 534 (for EPL)											L
	DIN VDI/VDE 3845 (for EPR-NAMUR)											R
	DHCT bracket 80x30 (for EPR - Fork lever type)											F

6 Descriptions on Nameplates

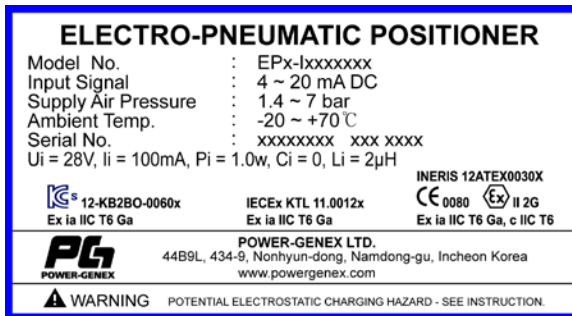

< Intrinsically safe Ex ia IIC T6 >

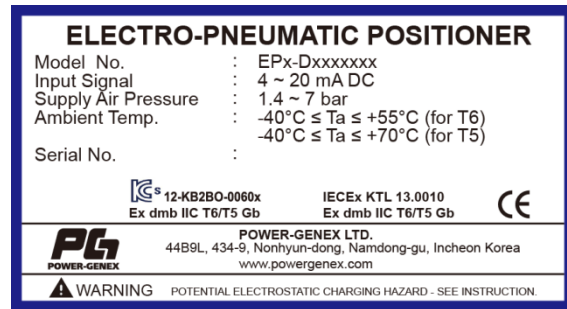

< Flameproof Ex dmb IIC T6/T5 >

- **Model No.:** Part number is described.
- **Input Signal:** 4-20mA current input signal is described.
- **Supply Air Pressure:** The supply air pressure range of 1.4 ~ 7 bar is described.
- **Ambient Temp.:** The operating ambient temperature range of -20 ~ +70°C is described.
- **Serial No.:** A serial number and a manufacturing date are described.
- **Ui , Ii, Ri, Pi, Li, Ci :** Intrinsic safety parameters are described.
- Certification bodies and certificate numbers are described.

7 Internal Views



Never move the seat adjuster. It was already set at the factory precisely.

7.1. EPL Positioner

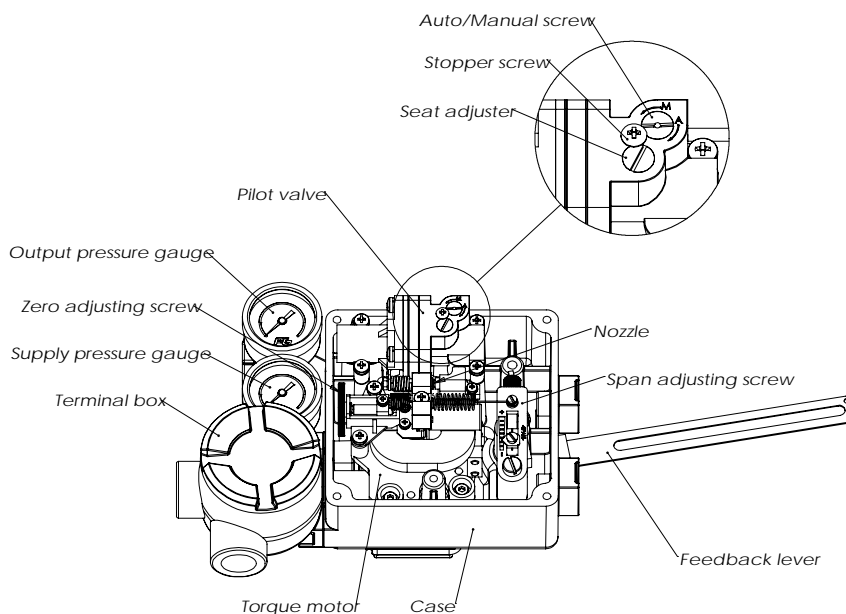

7.2. EPR Positioner

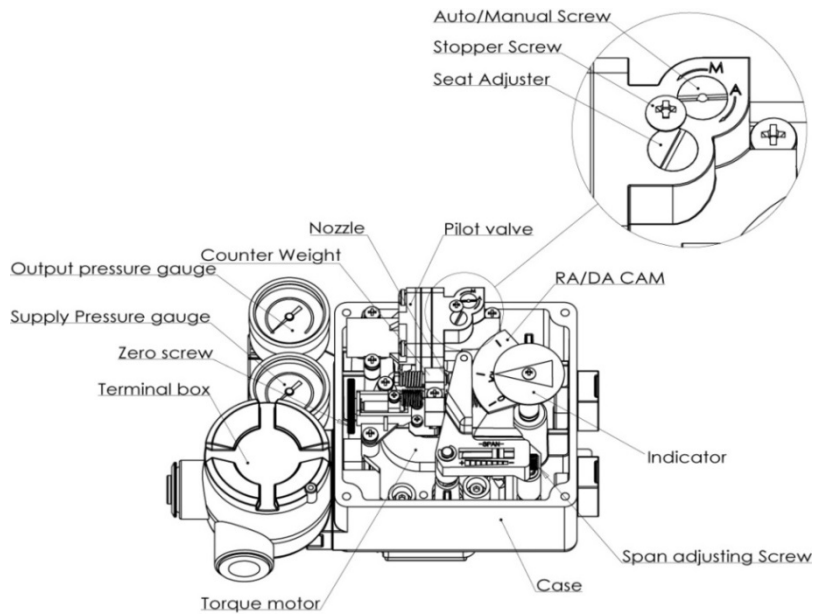

8 Installation



To reduce the risk of ignition of hazardous atmospheres, disconnect the device from the supply circuit before opening. Keep assembly tightly closed during operation.

8.1. Mounting of EPL Positioner

8.1.1. Mounting and Attaching Feedback Lever

- ① Mount the EPL positioner to the control valve as shown to the right.
- ② Fix the EPL positioner and the feedback lever to the control valve stem at position where the angle between the valve stem is settled to 90 degrees as shown below when the input signal is set to 12mA (50%). Be sure that the elimination spring should be installed.
- ③ The feedback lever A is for stroke 10~40mm and the feedback lever B is for stroke 10~80mm. For up to stroke 150mm, please connect a feedback lever A and a feedback lever B with each other. The operation angle of the EPL positioner is minimum 10° and maximum 30°.

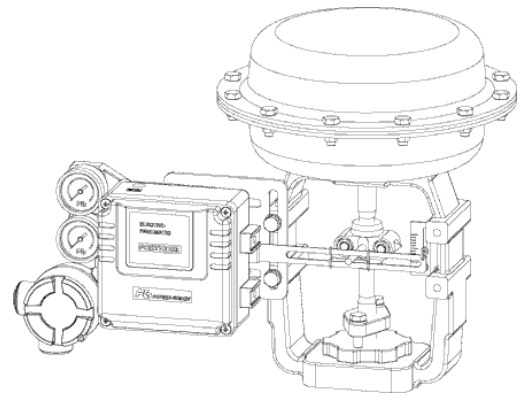

Connect the feedback lever and the enclosed additional feedback lever with each other for a stroke extension of over 80mm.

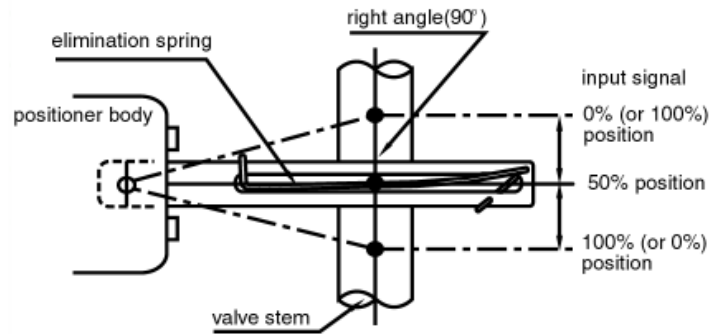

< Installation of Elimination Spring >

8.1.2. Position of Span Adjuster According to Actuator Type (RA or DA)



When adjusting or replacing a span adjuster, be sure to shut off air supply to the EPL positioner. Otherwise, the EPL positioner might react suddenly and cause damage or injury.

Span adjuster is set to RA (reverse acting) as a standard factory setting. But it is necessary to re-set its position for DA (direct acting) as shown below.

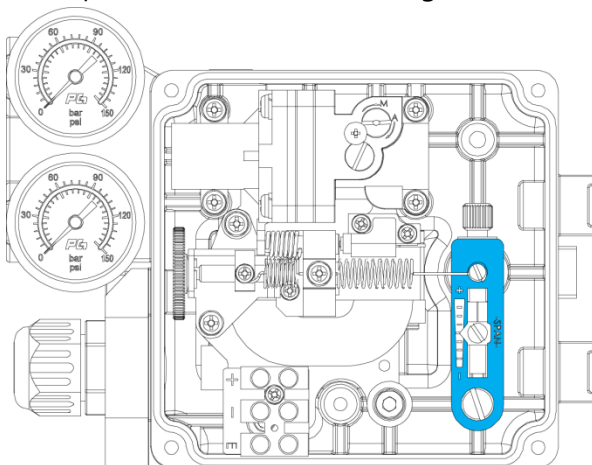

< RA Type – Factory setting >

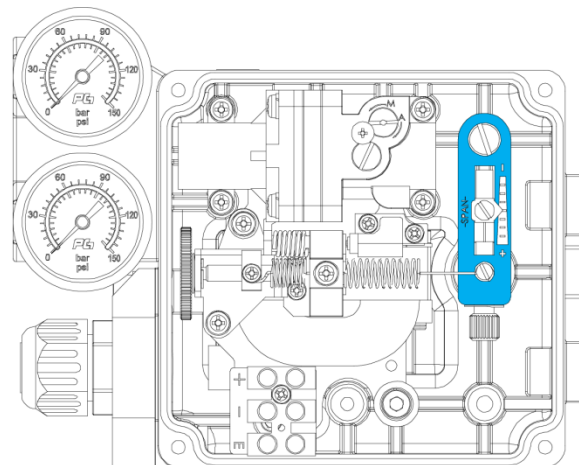

< DA Type >

8.2. Mounting of EPR Positioner

8.2.1. Mounting with NAMUR type

The EPR positioner has the NAMUR shaft as standard which can be directly mounted to the top pinion (VDI/VDE 3845) of the pneumatic rotary actuator.

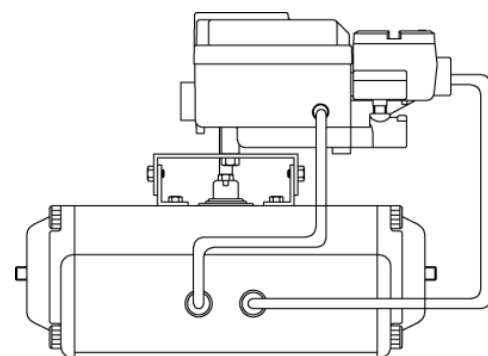

NAMUR Mounting

EPL / EPR Series

- ① Mount the NAMUR multi-size bracket to the pneumatic rotary actuator with the enclosed bolts (4 x M5) as shown to the right.
- ② Mount the EPR positioner to the bracket and insert the EPR positioner feedback shaft into the actuator top pinion (output shaft) as shown to the right.
- ③ Fix the EPR positioner to the bracket with the enclosed bolts (4 x M6).

A multi-size bracket is assembled for 80x30x20 as a standard factory setting. But the user can re-assemble it for 80x30x30, 130x30x20, and 130x30x30 according to requirements as shown below.

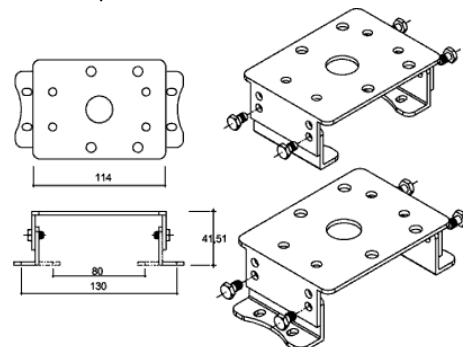

Multi-size bracket (NAMUR mounting)

8.2.2. Mounting with Fork Lever Type

Mount the EPR positioner to the actuator with DHCT bracket (80x30) as shown to the right. Be sure that the feedback lever shaft "A" is placed in the orifice for the fork lever "B" and they are in alignment with a rotary actuator output shaft.



DHCT bracket (80 x 30)

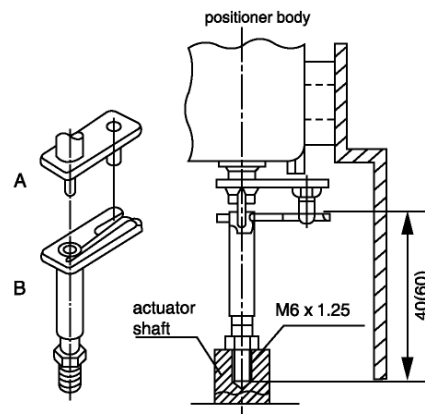

Fork lever type mounting

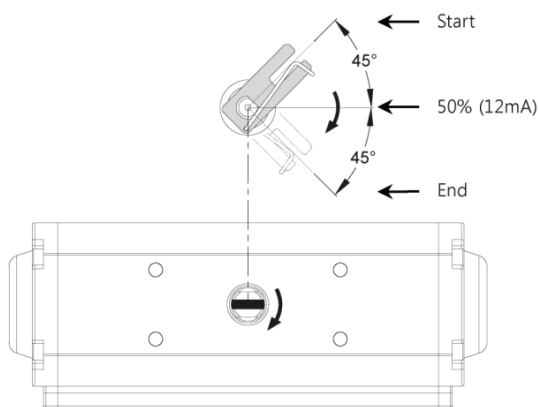

Clockwise movement

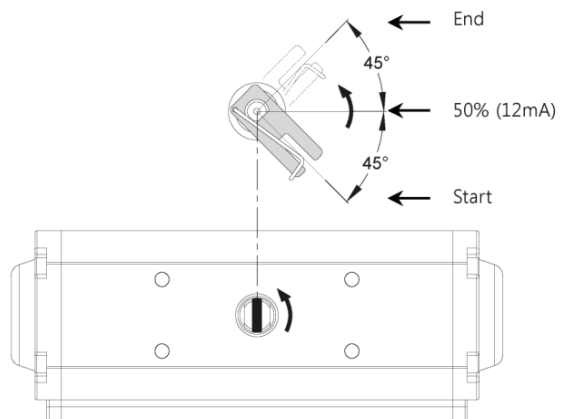

Counter-clockwise Movement

EPL / EPR Series

8.2.3. Adjustment of Cam and Indicator



When adjusting or replacing cams, be sure to shut off air supply to the EPR positioner. Otherwise, the EPR positioner might react suddenly and cause damage or injury.

- RA (reverse acting) is a standard factory setting.

① Loosen a flange nut on a cam and reverse a cam for DA setting. Match the part of the cam with "0" marked on it with the center of bearing as shown below. The span adjusting arm unit should now be aligned.

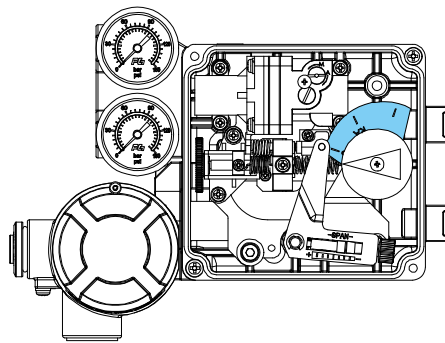
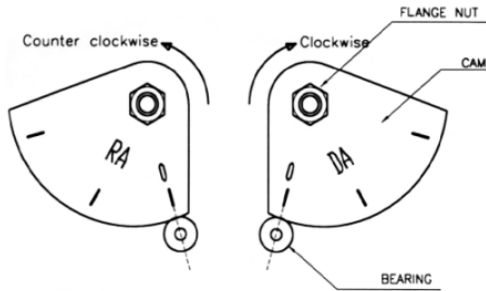

< Reverse Acting(RA) >

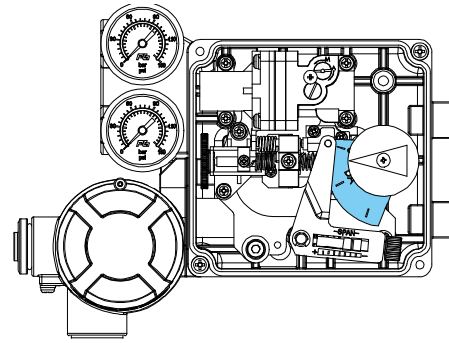

< Direct Acting (DA) >

② Tighten the flange nut of the cam after setting the cam.

③ After cam installation, proceed to adjust zero and span. Once this is complete, secure the indicator with the bolt (M6) to the feedback shaft according to the actuator type (RA or DA) as shown below. The position for the indicator should be arranged in the scale (0 - 90°) shown on the cover.

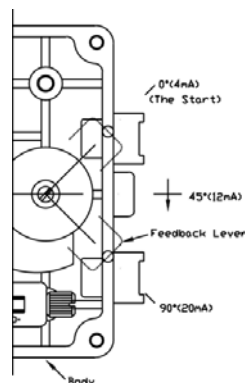

[RA]

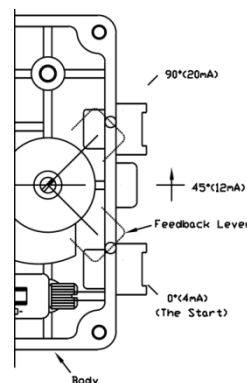

[DA]

EPL / EPR Series

9 Air Connections

9.1. EPL Positioner

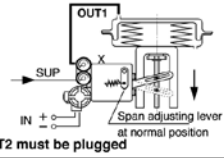
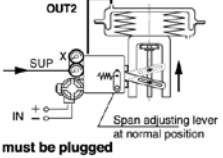
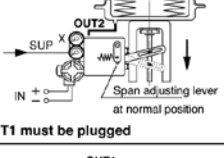
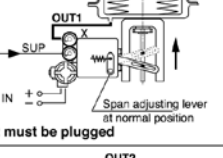
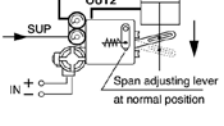
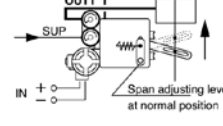
Direct Acting (DA)		Reverse Acting (RA)	
As the input signal increases, Valve stem moves downwards Actuator : DA Connection : Out 1		As the input signal increases, Valve stem moves upwards Actuator : RA Connection : Out 2	
As the input signal increases, Valve stem moves downwards Actuator : DA Connection : Out 2		As the input signal increases, Valve stem moves upwards Actuator : RA Connection : Out 1	
As the input signal increases, Valve stem moves downwards		As the input signal increases, Valve stem moves upwards	

9.2. EPR Positioner

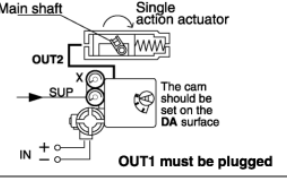
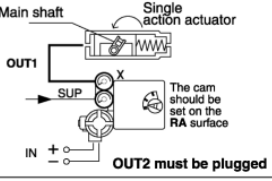
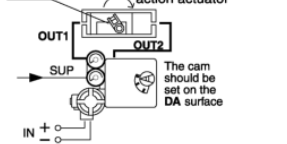
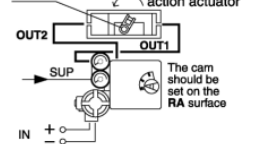
Direct Acting (DA)		Reverse Acting (RA)	
Increasing the input signal, Actuator stem rotates clockwise.		Increasing the input signal, Actuator stem rotates counter clockwise.	
Increasing the input signal, Actuator stem rotates clockwise.		Increasing the input signal, Actuator stem rotates counter clockwise.	

EPL / EPR Series

10 Electrical Connections



- ① Always check that the electrical load is within the range stated on the nameplate. Failure to remain within electrical ratings may result in damage to or premature failure of the electrical switches, sensors or transmitter electronics.
- ② Check polarity of + and – exactly and connect wires.
- ③ When it is necessary to open the positioner cover at a humid place, more attention is required. It may cause a serious damage or malfunctions.

10.1. General Wiring

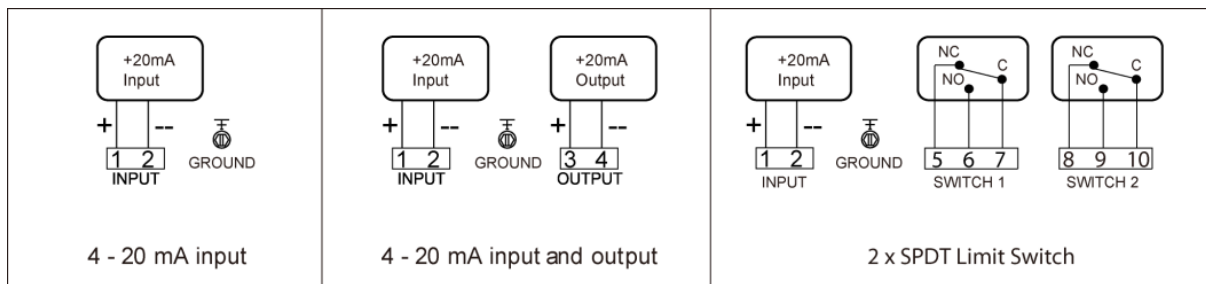

10.2. Wiring for Intrinsic Safety Ex ia IIC T6

10.2.1. Connection to Terminals



The intrinsically safe EPL / EPR series are designed for the intrinsic safety standards of IEC/EN 60079-0, IEC/EN 60079-11, EN 13463-1, EN 13463-5. Note that it can be influenced by an electrical or magnetic energy from other electronic devices. Therefore, do not open when it is energized.

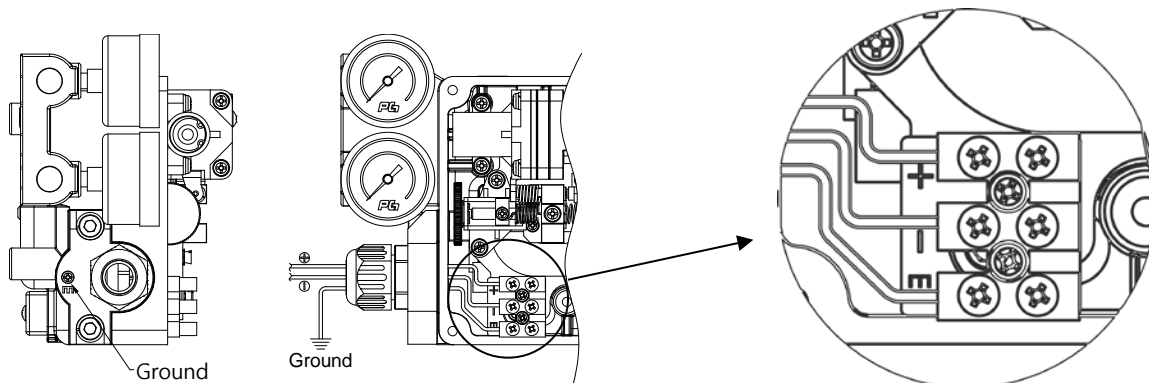

EPL / EPR Series

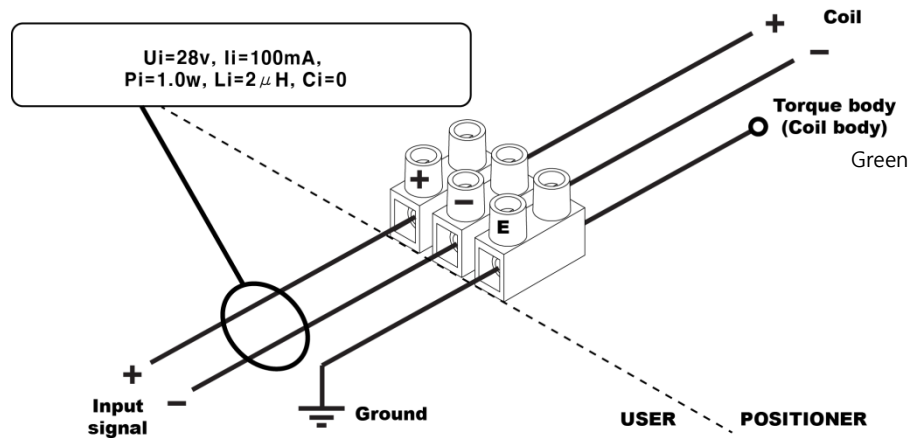

- ① Select a proper safety barrier that can meet parameters of the intrinsically safe EPL / EPR positioner. Also, consider Li and Ci according to a cable length.
- ② Be sure to disconnect a power supply before connecting wires to terminals and confirm + - clearly when connecting wires.
- ③ Tighten a fixing screw so that a cable cannot be pulled out or left away.
- ④ Protect cables from an external damage.
- ⑤ Ground the intrinsically safe the EPL / EPR positioner.

10.2.2. Connection to Cable Gland

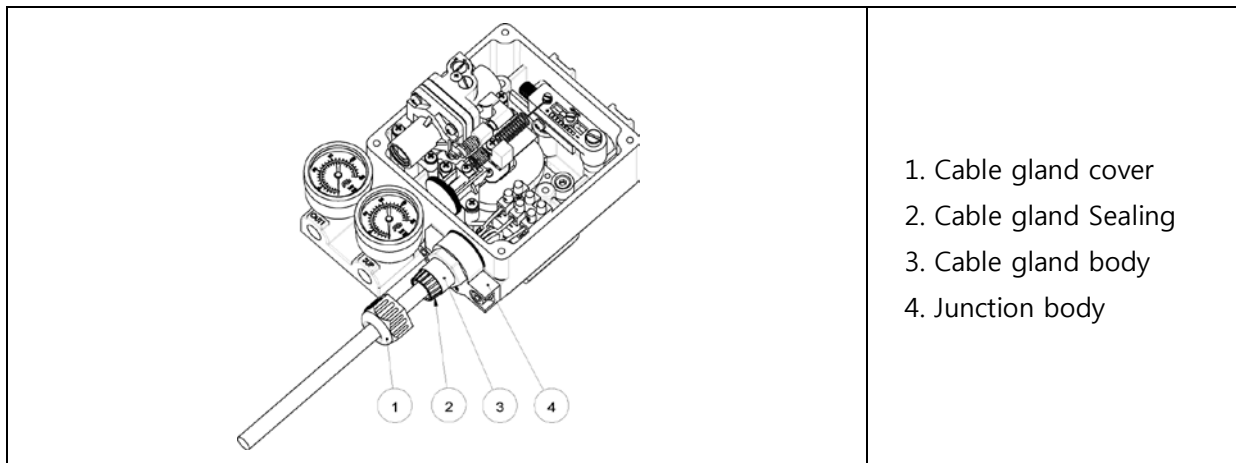

1. Cable gland cover
2. Cable gland Sealing
3. Cable gland body
4. Junction body

- ① Dis-assemble a cable gland by turning a cable gland cover counter-clockwise
- ② Insert a cable into the positioner through a cable gland as shown above and fix by turning a cable gland cover clockwise.



Below are specifications of a cable that fits the cable gland supplied as standard with intrinsically safe EPL / EPR positioner.

- External diameter: Max. 12.5mm
- Internal diameter: Min. 9mm

EPL / EPR Series

10.3. Wiring for Flameproof Ex dmb IIC T6/T5, Ex dmb IIB T6, Eex md IIB T5



The EPL / EPR series certified to ATEX Eex md IIB T5 must be connected to a fuse with the following ratings:

- Max 125mA, breaking capacity 35A
- Suitable 1/2" PF threaded certified EEx d cable glands and plugs must be used.



① Be sure to use the flameproof-approved wires and cable glands in the gas area or in the potentially-explosive area. Use the cables suitable for the diameter of the NBR packing when using the flameproof-approved cable glands.

② Cable entries have PF 1/2(G 1/2).

③ Do not open the terminal box cover when energized. Disconnect a power supply before opening the terminal box cover and wait until a power supply is cut off completely.

④ Use the ring type wire connector so that it cannot be disconnected easily.

10.3.1. Connection to Cable Gland

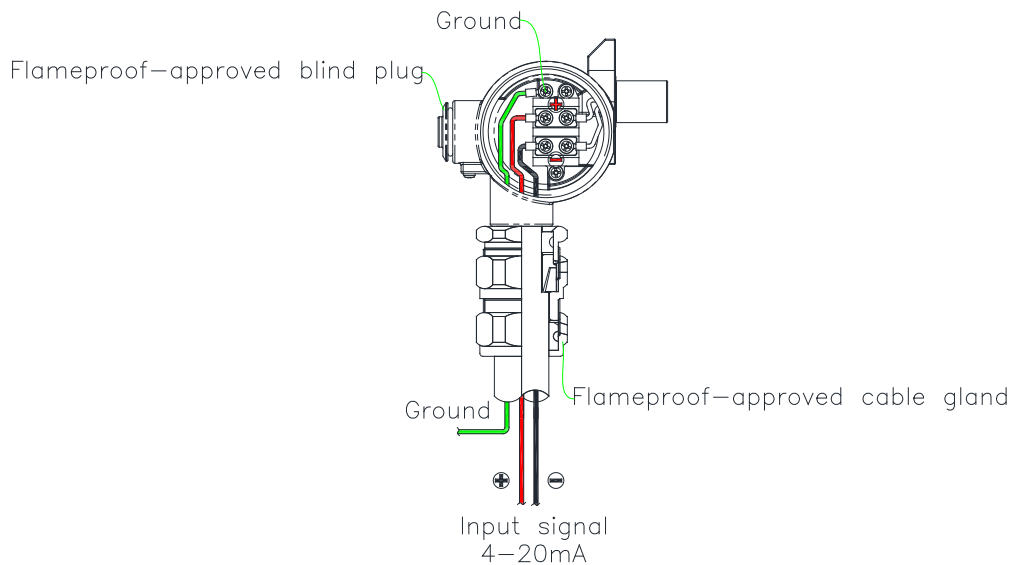

- ① Open the terminal box cover by loosening the fixing bolt on the terminal box cover.
- ② Install the flameproof-approved cable glands tightly and insert a wire into the terminal box. Use and fix the NBR packing tightly so that the inside of the terminal box can be sealed up.
- ③ Connect external + to internal + and external - to internal -.
- ④ Fix the terminal bolts tightly.
- ⑤ Close the terminal box cover and turn the fixing bolt completely.

11 Setting of Span and Zero

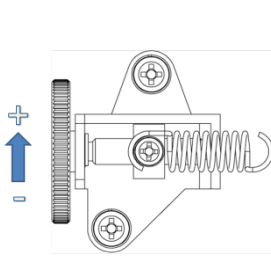

< Zero Adjuster >

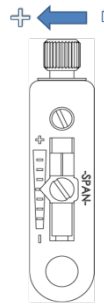

< Span Adjuster – EPL >

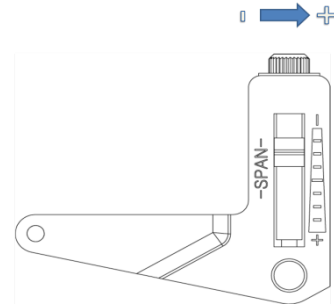

< Span Adjuster - EPR >

- ① Check the proper installation of the EPL positioner and the feedback lever.
- ② Check the proper position of a span adjuster according to the actuator type (direct acting or reverse acting).
- ③ Connect all air connections.
- ④ Supply air and set the input signal to 4mA. Turn the zero adjusting screw clockwise or counter clockwise to set the zero position.
- ⑤ Check the stroke of the control valve by setting the input signal to 20mA. If the stroke does not meet 100%, turn the span adjusting screw clockwise or counter clockwise until 100% is reached.
- ⑥ Set the input signal back to 4mA and adjust the zero adjusting screw until the zero point is reached.
- ⑦ Repeat the process of ④ to ⑥ until the desired set points are reached.
- ⑧ If the strokes of the control valve perfectly meet 0% and 100%, each setting point of 8, 12, and 16mA is automatically reached.



Due to variations in circuitry and environmental effects, often 0% is set at 4.5mA and 100% at 19.5mA to make sure that at the end points the valve will be fully open or fully closed.

12 Position Transmitter and Limit Switches

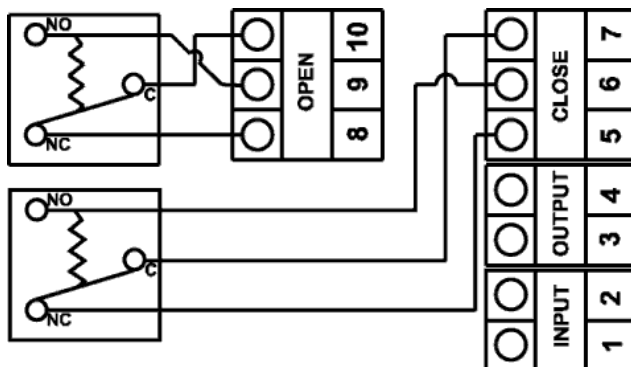

EPL / EPR Series

12.1. Position Transmitter (4 – 20mA output signal)

12.1.1. Board View

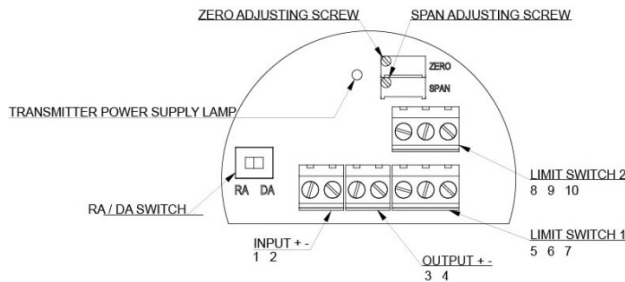

12.1.2. Specifications

Power Supply Rating	5.5 ~ 30V DC loop-powered
Recommended Power Supply	24V DC
Output Signal	4~20mA
Operating Temperature	-20° to 70°C
Load Impedance	0~600 ohms
Max. Output	30mA DC
Linearity	± 1.0 %
Hysteresis	1.0 % of full scale
Repeatability	± 0.5 % of full scale
Adjustment	Zero and Span in terminal box

12.1.2.A. With mA loop calibrator

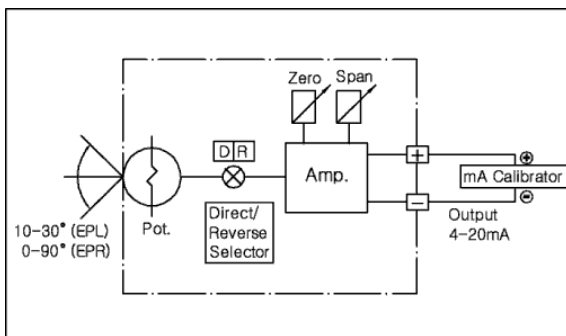

12.1.2.B. With multi-meter tester

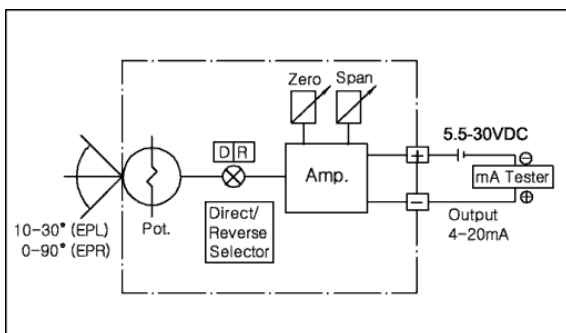

EPL / EPR Series

12.1.3. With multi-meter tester

- ① Select RA or DA on a board in the terminal box. For reference, RA (reverse acting) is a standard factory setting.
- ② Supply 4mA input signal and turn the zero adjusting screw on a board clockwise or counter clockwise until output signal becomes 4mA.
- ③ Supply 20mA input signal and turn the span adjusting screw on a board clockwise or counter clockwise until output signal becomes 20mA.
- ④ Repeat the process of ② to ③ until output signal approaches input signal.



- ① Be sure that Span and Zero of the EPR positioner should be exactly set before setting Span and Zero of the position transmitter.
- ② Be sure that 5.5 - 30V DC should be supplied in case of using the mA tester (multimeter tester).
- ③ Check if the transmitter power supply lamp is on.

12.2. SPDT Mechanical Limit Switches (open / close)

Contacts	SPDT Form C
AC Rating	16A 1/2HP 125/250VAC
DC Rating	0.6A 125VDC / 0.3A 250VDC
Adjustment	Cams with set screws (L-wrench included for setting)

13 Optional Restricted Pilot Valve Orifice



Before removing the pilot valve, be sure to disconnect the EPL / EPR positioner from the signal and compressed air source

For improved control using smaller actuators, a restricted pilot valve orifice kit is included with the EPL / EPR positioner. To install, the pilot valve must be removed from the EPL / EPR positioner. Remove four screws holding the pilot valve to the EPL / EPR positioner body. As you remove the pilot valve, be sure to hold the compensation spring in place. Flip the valve so the bottom faces you. Remove the O-rings from the out 1 and out 2 ports (as shown in the diagram at right). Place the orifice plates in their place with new O-rings above them, and re-install the pilot valve, making sure the compensation spring is back in place. The EPL / EPR positioner is now set up for smaller actuators.

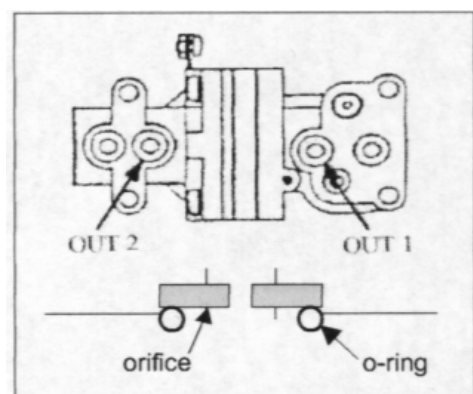

14 Troubleshooting Tips

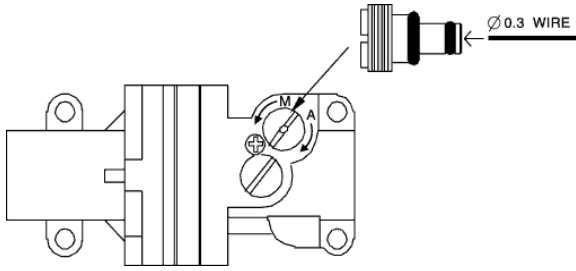
Trouble	Solution
Hunting happens with a small pneumatic actuator	The actuator is very small. Install two orifices at the bottom of the pilot valve as instructed in 12. Optional Restricted Pilot Valve Orifice.
	If the actuator is not small, check if a position shaft is inserted into the output shaft of the actuator exactly. If there is a gap between these shafts, make it tight.
Valve is always open regardless of input signal.	<p>The orifice of the Auto/Manual screw on the pilot valve is clogged. Disconnect supply air and clean the orifice with a wire attached inside of the EPR positioner cover as shown below.</p>  <p>▲ Never move the seat adjuster. It was already set at the factory precisely.</p>
Valve is always opens or closed with input signal	The air connections are not made properly. Check again if the pneumatic actuator type is RA (reverse acting) or DA (direct acting) and make the proper air connections. See Air Connections.
Linearity is very poor	<ol style="list-style-type: none"> ① Check if the 1.4 ~ 7 bar air is supplied properly. ② Check if the EPL positioner is installed properly. The feedback lever should be positioned horizontally at 50% input signal. ③ Check if the EPR positioner and the mounting bracket are installed properly and tightly. ④ Check if Zero and Span are set properly.
Hysteresis is very poor	<ol style="list-style-type: none"> ① Check if the mounting bracket is installed tightly. ② Check if the valve stem pin of the EPL positioner is installed and connected to the feedback lever properly. ③ Check if the feedback lever spring of the EPL positioner is installed properly.
Valve moves too slowly	An actuator is too big. Use the air volume booster.

15 Dimensions

15.1. EPL Positioner

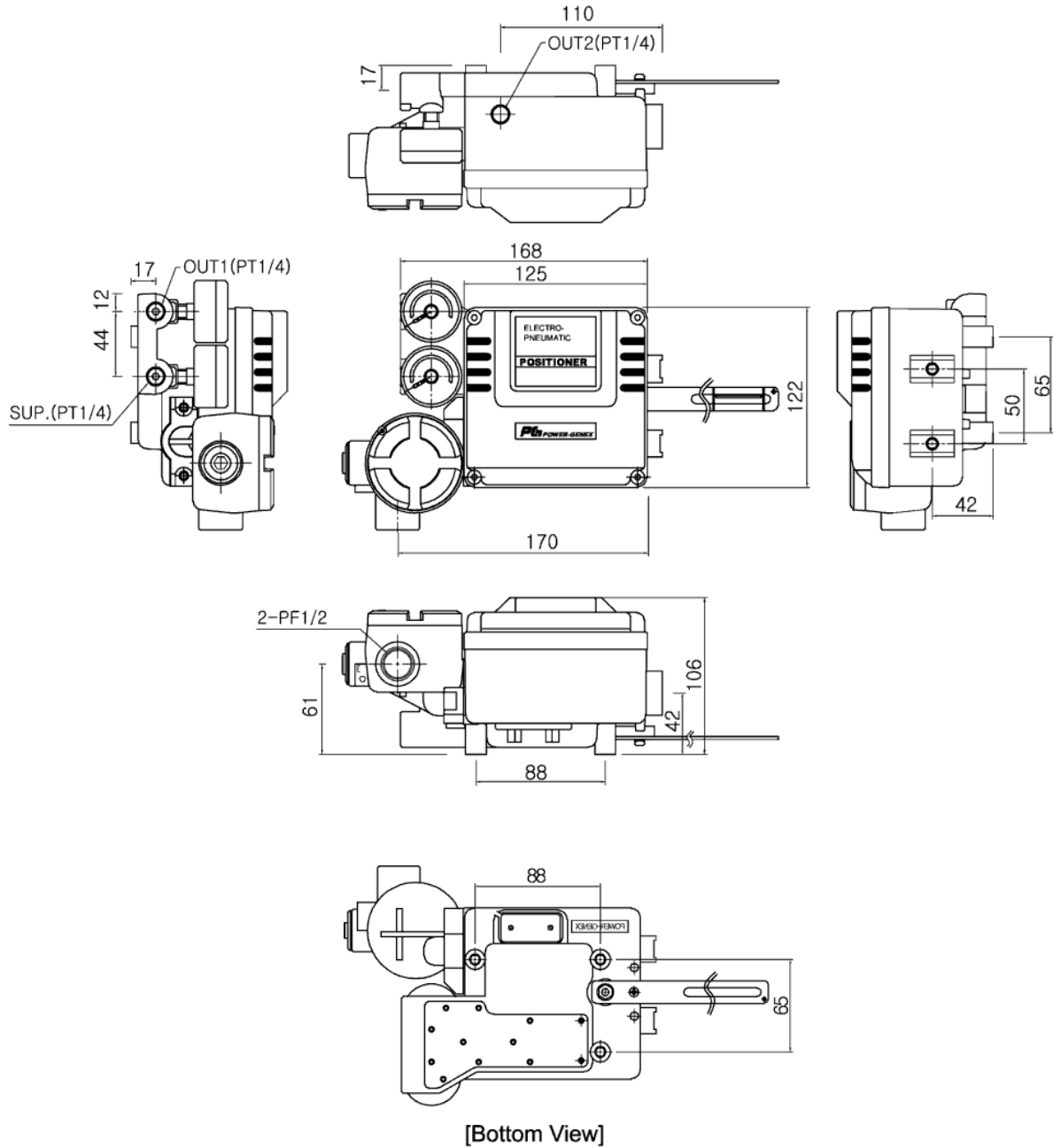

15.2. EPR Positioner

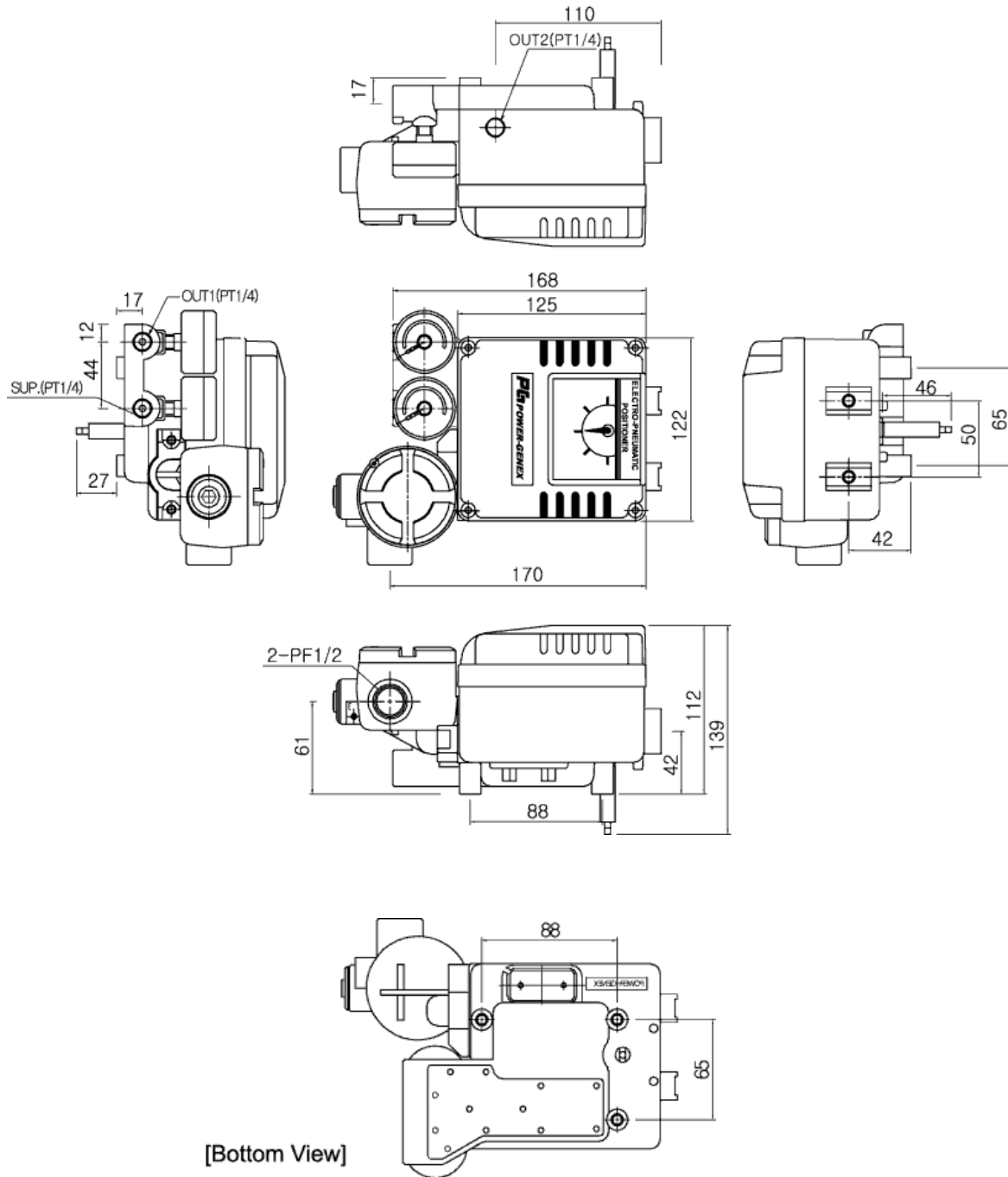

Warranty

1. The warranty period of the product is 1 year in service or 1.5 years after the product is delivered.
2. For any failure or damage reported within the warranty period which is clearly our responsibility, a replacement product or necessary parts will be provided. This limited warranty applies only to our product independently, and not to any other damage incurred due to the failure of the product.
3. Prior to using POWER-GENEX products, please read and understand the warranty terms and disclaimers noted in the specified catalogue for the particular products.
4. If maintenance is required, you can contact with distributors, agents or directly with Power-Genex. A proper and satisfactory customer service will be provided.

KLINGER Denmark A/S

Nyager 12 , DK-2605 Broendby Denmark

Tel : +45 43646611

Website : www.klinger.dk

E-mail : info@klinger.dk

Subject to change without prior notice
