

Operating Instructions

- 1.1 Warranty
- 1.2 Installation
- 1.3 Use
- 1.4 Maintenance
- 1.5 Recommendations

1.1 Warranty. Definition: the warranty is defined as the maximum time from the date of placing the valve on the market** beyond which MEI Valvole Industriali Srl can no longer ensure compliance with the safety requirements of Directive 2014/68/EU. The warranty is, however, subject to proper planning of maintenance work as set out in section 1.4, proper use in consideration of the temperatures, pressures and fluids compatible with the materials (section 1.3) and proper installation (section 1.2)

This period is identified as the “**life span**” of the valve and varies between models:

- clapet check valve type CV, CS in EN 1.4401/1.4404 (AISI 316/316L), 1.4462 / 1.4410 and 1.4501 (duplex/ SuperDuplex), EN 1.4571 (AISI 316 Ti): **60 months.**
- clapet check valve type CV, CS in carbon steel 1.0553 (S355J2+N), GP240GR (1.0621), ASTM A 216 (WCB), 1.1106 (P355 NL): **48 months.**
- clapet check valve type CV and CS in aluminium bronze (CB331G/CC331G) prospectus 32 EN 1982: **60 months**

** Placing on the market: the first time that a MEI Valvole Industriali srl clapet check valve is put on the European Union market, whether at a cost or free of charge, for the purpose of marketing or use.

1.2 Installation. The installation of the valve on the system must be carried out in accordance with the attached Installation Diagram. Installation should only be carried out between flanges and at least 2 metres from the pump.

Check that the pipeline flow direction corresponds to the arrows on the valve marking.

MEI Valvole Industriali Srl shall not be liable for damage caused to persons, property or animals due to improper use of the product.

Made in Italy,
certificato e garantito.



1.3. Use. Definition of clapet check valve: a valve that automatically opens when fluid passes in a defined direction and automatically closes to prevent fluid flow in the opposite direction.

Caution: The valve is not intended for use as a shut-off (isolation) nor as a safety valve.

Caution: The clapet valves manufactured by MEI valvole industriali srl **cannot** be used for applications with **unstable fluids**.

Working conditions for max. pressure and max. and min. temperature are those indicated on the valve marking.

Summary of minimum and maximum working temperature conditions for valve materials in combination with the elastomers used:

abbreviations: carbon steel (C), stainless steel (I), Duplex (D), aluminium bronze (B), Nitril- butadiene - abbreviation NBR 70 (N), Ethylene-propylene - abbreviation EPDM (E), Fluorinated polymer - abbreviation FKM/FPM (V), P.T.F.E. (T), Metal (Met), WCB (W), P 355 NL (P).

MEI Valvole Industriali srl delegates the choice of the valve materials most suitable for the specific application to the user, where there is no clearly documented evidence of working conditions and especially information regarding fluid, temperatures and pressures.

1.4 Maintenance. Routine maintenance includes replacement for all models:

1. replacement of the valve's O-RINGS no more frequently than every 12 months.
2. replacement of clapets, screws, and washers no more frequently than every 36 months.

Caution: If there are particular conditions where the fluid is found to be aggressive or turbulent, the times indicated are significantly reduced.

MEI Valvole Industriali Srl disclaims all liability and warranty for products that have been repaired by third parties and/or have not undergone the recommended maintenance programme.

1.5 Recommendations. The recommendations are intended to prevent incorrect use of the clapet check valve:

1. valves may only be installed in accordance with the attached Application Procedures.
2. The flow on the system must have the same direction as the arrows indicated on the valve.
3. Remove the valve from the system only and solely by ensuring that the system is at a standstill and the temperature and pressure of the fluid can no longer pose a danger.
4. When connecting the valve to the flanges, ensure that there is no dirt or fluid residue between the contact faces that may compromise the seal.

Made in Italy,
certificato e garantito.



DICHIARAZIONE DI CONFORMITÀ UE [EU DECLARATION OF CONFORMITY]

Attrezzatura a pressione [Pressure equipment]: **Valvole [Valve] CV, CS, CD.**

Nome e indirizzo del fabbricante [Name and address of the manufacturer]:
MEI Valvole Industriali Srl, Via Stipeti 56, 55060 Coselli – Lucca – Italia

La presente dichiarazione di conformità è rilasciata sotto la responsabilità esclusiva del fabbricante.
[This declaration of conformity is issued under the sole responsibility of the manufacturer.]

Oggetto della dichiarazione [Object of the declaration]: **Valvole [Valve] CV.**
Misura/ [measure]: **DN 32 ÷ DN 500 per flange [for flanges] UNI PN 6 ÷ PN 40, per flange [for flanges] ANSI 150 ÷ ANSI 300**

Oggetto della dichiarazione [Object of the declaration]: **Valvole [Valve] CS.**
Misura/ [measure]: **DN 32 ÷ DN 350 per flange [for flanges] UNI PN 6 ÷ PN 40, per flange [for flanges] ANSI 150 ÷ ANSI 300**

Oggetto della dichiarazione [Object of the declaration]: **Valvole [Valve] CD Retainer.**
Misura/ [measure]: **DN 50 ÷ DN 250 per flange [for flanges] UNI PN 6 ÷ PN 40, per flange [for flanges] ANSI 150 ÷ ANSI 300**

Oggetto della dichiarazione [Object of the declaration]: **Valvole [Valve] CD Retainerless.**
Misura/ [measure]: **DN 50 ÷ DN 250 per flange [for flanges] UNI PN 10 ÷ PN 40, per flange [for flanges] ANSI 150 ÷ ANSI 300**

Procedura di valutazione di conformità utilizzata [Conformity Assessment Procedure followed]:

Modulo B + C2¹

L'oggetto della dichiarazione di cui sopra è conforme alla pertinente normativa di armonizzazione dell'Unione [The object of the declaration described above is in conformity with the relevant Union harmonisation legislation]:
Direttiva 2014/68/UE

Riferimento alle pertinenti norme armonizzate utilizzate o riferimenti alle altre specifiche tecniche in relazione alle quali è dichiarata la conformità [References to the relevant harmonised standards used or references to the other technical specifications in relation to which conformity is declared]:

UNI EN 19 (Valvole industriali - Marcatura delle valvole metalliche [Industrial valves - Marking of metallic valves])

UNI EN 12516-1 (Valvole industriali - Resistenza meccanica dell'involucro - Parte 1: Metodo tabulare per gli involucri delle valvole di acciaio [Industrial valves - Shell design strength - Part 1: Tabulation method for steel valve shells])

UNI EN 12516-2 (Valvole industriali - Resistenza meccanica dell'involucro - Parte 2: Metodo di calcolo per gli

¹Riferimento Art. 48 comma 3 Direttiva 2014/68/UE

involucri delle valvole di acciaio [*Industrial valves - Shell design strength - Part 2: Calculation method for steel valve shells*])

UNI EN 12516-4 (Valvole - Resistenza meccanica dell'involucro Parte 4- Metodo di calcolo per gli involucro delle valvole realizzati in materiali metallici diversi dall'acciaio [*Industrial valves - Shell design strength - Part 4: Calculation method for valve shells manufactured in metallic materials other than steel*])

UNI EN ISO 9712 (Prove non distruttive - Qualificazione e certificazione del personale addetto alle prove non distruttive [*Non-destructive testing - Qualification and certification of NDT personnel*])

UNI EN 1982 (Rame e leghe di rame - Lingotti e getti [*Copper and copper alloys - Ingots and castings*])

UNI EN 12266-1 (Valvole industriali - Prove di valvole metalliche - Prove in pressione, procedimenti di prova e criteri di accettazione - Requisiti obbligatori [*Industrial valves - Testing of metallic valves - Part 1: Pressure tests, test procedures and acceptance criteria - Mandatory requirements*])

UNI EN 736-1 (Valvole - Terminologia - Definizioni dei tipi di valvole [*Valves - Terminology - Definition of types of valves*])

Nome e indirizzo dell'organismo notificato che ha effettuato il controllo

[*Name, address and number of the notified body which carried out the conformity assessment*]

TUV RHEINLAND ITALIA SRL

ON 1936 Via Mattei 3, 20005, Pogliano Milanese (MI)

Attestato esame "UE del tipo - tipo di produzione" [*EU Type examination - Production Type*]: I-202-IT/Bp-22 0057
Modulo C2: I-202-IT/C2-22 0059"

Firmato a nome e per conto di [*Signed for and on behalf of*]:

Lorenzo MEI (General Manager)



Lucca, 02.04.2024

Made in Italy,
certificato e garantito.



1

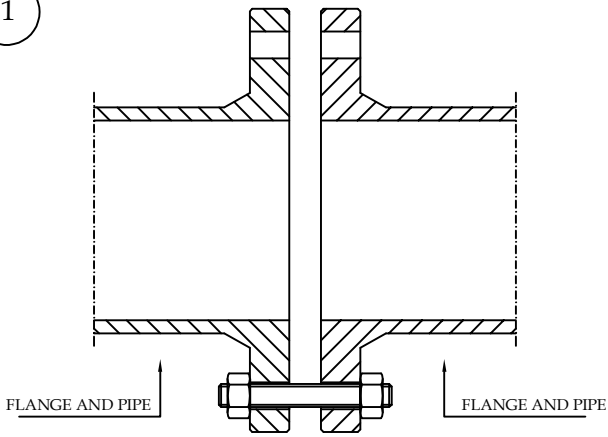

Insert one or two stud bolts and tighten them with nuts without forcing

2

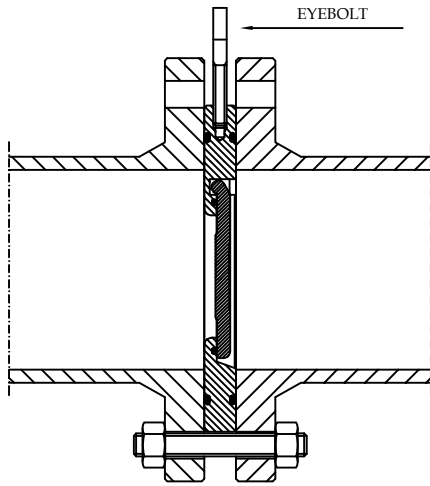

Holding the valve by the eyebolt, lower and set it on the already inserted stud bolt

3

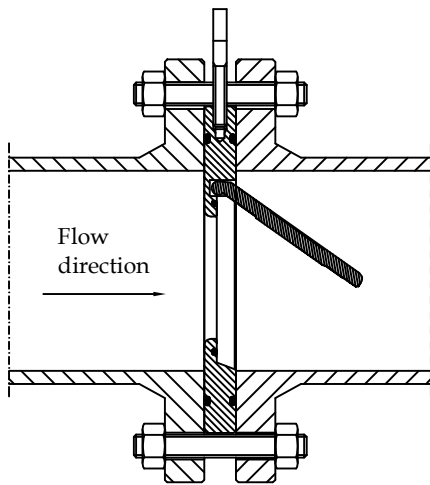

Insert the other stud bolts and tighten them with the nuts. Be sure that the valve's external diameter is equidistant from the screws and that the direction of the arrows on the external diameter is the same as the one of the flow

REV.	DATE	DESCRIPTION			MODIFIED BY	
DIMENSIONS WITHOUT TOLERANCES INDICATION: EN 22768-1 - f		approved		[Signature]		
sm.n.qu.		scale	designed		[Signature]	
1:1		date		21-01-02		
Object		drawing		rev.		
INSTALLATION SHEET		211.007.03		A		
MEI VALVOLE INDUSTRIALI srl PROPERTY. NO AUTHORIZED REPRODUCTION, DISCLOSURE AND EXECUTION IS ALLOWED				sheet 1 of 1		



VALVOLE INDUSTRIALI SRL
LUCCA

VERTICALLY ASSEMBLED VALVE
ON HORIZONTAL PIPELINE

RIGHT APPLICATION FOR ALL TYPES

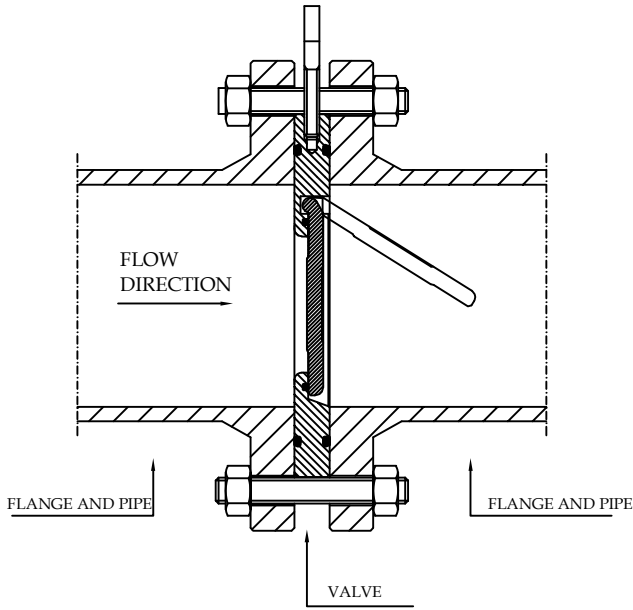

HORIZONTALLY ASSEMBLED VALVE ON
VERTICAL PIPELINE WITH UPHILL FLOW
RIGHT APPLICATION FOR ALL TYPES

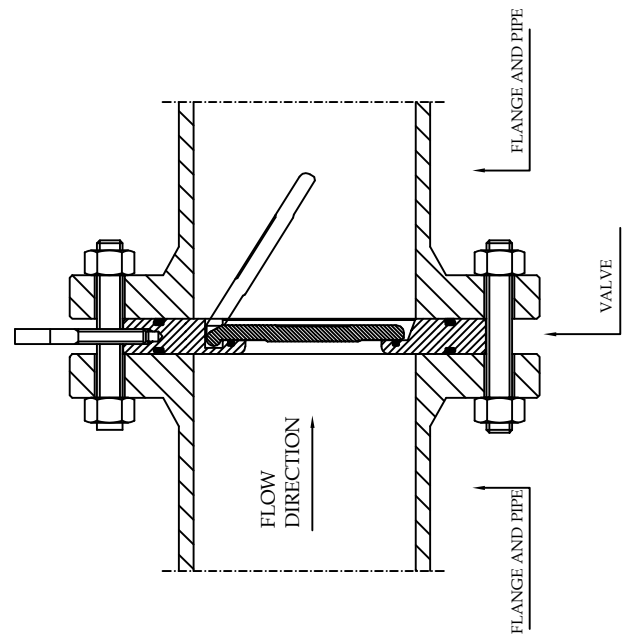

HORIZONTALLY ASSEMBLED VALVE ON
VERTICAL PIPELINE WITH DOWNHILL FLOW
RIGHT APPLICATION ONLY FOR "CS" AND "CC" TYPES

DO NOT USE FOR "CV" TYPE
DO NOT USE FOR "CD" TYPE

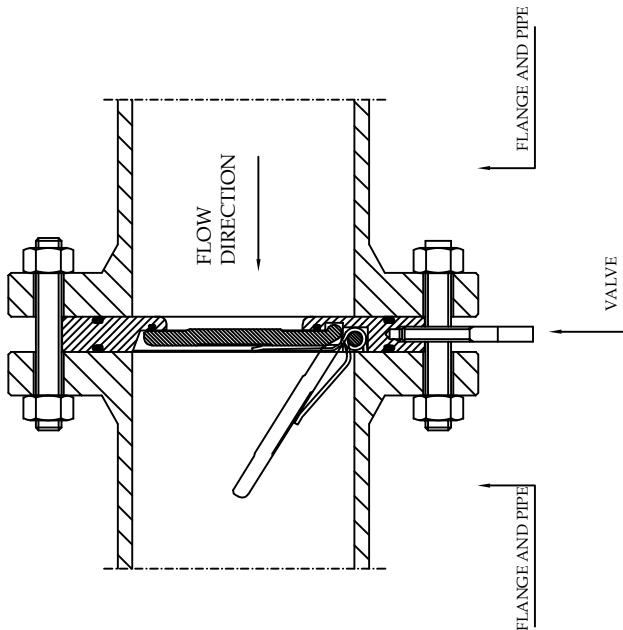

REV.	DATE	DESCRIPTION			MODIFIED BY	
DIMENSIONS WITHOUT TOLERANCES INDICATION: EN 22768-1 - f		approved		<i>[Signature]</i>		
		sm.n.qu.	scale		designed	
		Object	1:1		<i>[Signature]</i>	
		WORKING PLANE			date	21-01-02
					drawing	211.007.02
					rev.	A
MEI VALVOLE INDUSTRIALI srl PROPERTY. NO AUTHORIZED REPRODUCTION, DISCLOSURE AND EXECUTION IS ALLOWED					sheet	1 of 1

Drawing 211.007.03 A INSTALLATION DIAGRAM:

- (I) Inserire una o due viti prigioniere e serrare con i dadi senza forzare
(D) Eine oder zwei Stiftschrauben einsetzen und mit den Muttern festschrauben, nicht zu fest anziehen.
(E) Introducir uno o dos tornillos y apretar con las tuercas sin forzar
(F) Introduire une ou deux prisonniers et serrer avec les écrous sans forcer trop
(GB) Insert one or two stud bolts and tighten them with nuts without forcing
(S) Sätt I en eller två stiftskruvar och dra åt med muttrarna utan att ta I för kraftigt
- (I) Calare la valvola dall'alto sostenendola dal golfare e appoggiarla sulla vite prigioniera precedentemente inserita
(D) Die Klappe an der Ösenschraube festhalten und von oben herablassen; auf die zuvor eingesetzte Stiftschraube auflegen.
(E) Meter la válvula desde arriba sujetandola por la argilla y apoyarla sobre el tornillo prisionero introducido con anterioridad
(F) Baisser le clapet de haut en bas en la tenant de la cheville à œillet et l'appuyer sur le prisonnier précédemment inséré .
(GB) Holding the valve by the eyebolt, lower and set it on the already inserted stud bolt
(S) Sänk ned ventilen genom att hålla fast den I lyftöglan och placera den på den stiftskruv som redan har satts i
- (I) Inserire gli altri prigionieri e serrare con i dadi accertandosi che il diametro esterno della valvola sia equidistante dalle viti e le frecce sull'etichetta del diametro esterno abbiano la stessa direzione del flusso.
(D) Die übrigen Stiftschrauben einsetzen und mit den Muttern festschrauben; es ist sicherzustellen, dass der Außendurchmesser der Klappe den gleichen Abstand von den Schrauben besitzt und die Pfeile auf den Etikett des Außendurchmessers die gleiche Strömungsrichtung aufweisen.
(E) Introducir los otros tornillos prisioneros y apretar con las tuercas asegurándose de que el diámetro exterior de la válvula sea equidistante de los tornillos, y de que las flechas de la etiqueta del diámetro exterior tengan la misma dirección del flujo.
(F) Insérer les autres prisonniers et serrer au moyen des écrous en s'assurant que le diamètre extérieur du clapet est équidistant des vis et les flèches sur l'étiquette du diamètre extérieur aient la même direction d'écoulement.
(GB) Insert the other stud bolts and tighten them with the nuts. Be sure that the valve's external diameter is equidistant from the screws and that the direction of the arrows on the external diameter is the same as the one of the flow
(S) Sätt I de andra stiftskruvarna och dra och dra åt med muttrarna, kontrollera att ventilens yttre diameter befinner sig på samma avstånd från skruvarna samt att pilarna på etiketten för den yttre diametern går I samma riktning som flödesströmmen.

Drawing 211.007.02 A INSTALLATION PROCEDURE:

1. (I) Valvola montata verticale su tubazione orizzontale. Applicazione corretta per tutti i modelli.
(F) Soupape montée verticale sur tubulure horizontale. Application correcte pour tous les modèles.
(D) Vertikal auf horizontaler Leitung montiertes Ventil. Korrekte Anwendung für alle Modelle.
(GB) Vertically assembled valve on horizontal pipeline. Right application for all types.
(E) V á lvula montada vertical en una tubería horizontal. Aplicación correcta para todos los modelos.
(S) V entil som monterats vertikalt på horisontalt rör. Korrekt tillämpning för alla modeller.
2. (I) Valvola montata orizzontale su tubazione verticale con flusso ascendente.. Applicazione corretta per tutti i modelli.
(F) Soupape montée horizontale sur tubulure verticale avec flux ascendant. Application correcte pour tous les modèles.
(D) Horizontal auf vertikale Leitung montiertes Ventil mit aufsteigender Strömung. Korrekte Anwendung für alle Modelle.
(GB) Horizontally assembled valve on vertical pipeline with uphill flow. Right application for all types.
(E) Válvula montada horizontal en tubería vertical con flujo ascendente. Aplicación correcta para todos los modelos.
(S) V entil som monterats horisontalt på vertikalt rör med uppgående flödesströmning. Korrekt tillämpning för alla modeller.
3. (I) Valvola montata orizzontale su tubazione verticale con flusso discendente. Applicazione corretta solo per i modelli "CS". Non usare per il modello "CV".
(F) Soupape montée horizontale sur tubulure verticale avec flux descendant. Application correcte pour les modèles "CS" seulement. Ne pas utiliser pour le modèle "CV".
(D) Horizontal auf vertikale Leitung montiertes Ventil mit fallender Strömung. Korrekte Anwendung nur für Modelle "CS". Nicht für "CV" verwenden.
(GB) Horizontally assembled valve on vertical pipeline with downhill flow. Right application only for "CS" type. Do not use for "CV" type.
(E) Válvula montada horizontal en tubería vertical con flujo descendente. Aplicación correcta sólo para los modelos "CS". Non usar para el modelo "CV".
(S) V entil som monterats horisontalt på vertikalt rör med nedgående flödesströmning. Korrekt tillämpning endast för modellerna "CS". Skall inte användas för modell "CV".

Made in Italy,
certificato e garantito.

